

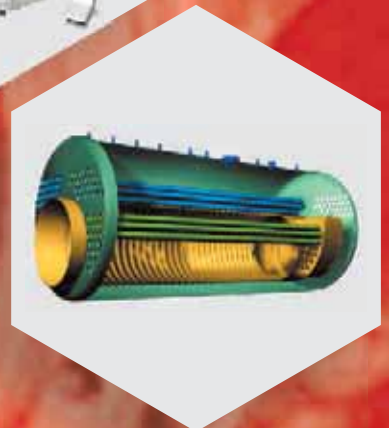

## TUBE TOOLS

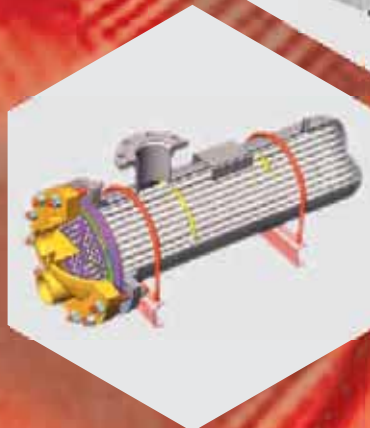

*Tools for every conceivable need.....*

[www.powermaster.in](http://www.powermaster.in)

## POWERMASTER LTD.

Powermaster was founded in 1972 by S. L. Advani, a mechanical engineer from England. After the initial years of struggle, through hard work, foresight and persistence the company evolved from a one man operation to a dynamic 300 plus person workforce distributed over six manufacturing facilities and seven global offices.

### QUALITY - PRICE - DELIVERY

- Quality - We have realised that to survive and grow in today's international market we must produce products equal to or better than the best available in the world, else we should cease from producing them. We also must provide our customers with added values to help us grow and increase our market share worldwide.
- Price - We will not attempt to sell a product worldwide if we are not able to offer our customers significant price savings. We will use our strengths of having a competitive labour force to decide on new products lines.
- Delivery - We will use our price advantage to increase our inventory levels to an extent that higher cost manufacturers would find difficult to match. We will attempt to ship out orders the same day via UPS, FED EX or DHL to our customers worldwide so it reaches them within days of the order. Automated inventory control, on-line ordering systems and our Same Day Shipment program ensure efficient order placement and execution cycles.

### ISO-9001 REGISTERED

ISO-9001 is a model for quality in design, production, installation and service. The system of procedures that we follow in Powermaster conforms to the guidelines of the ISO-9001 model. The company continues to implement and work within the guidelines of the ISO-9001 model.

© Copyright 2007

**Powermaster Engineers Pvt. Ltd.**

*Powermaster is a Trademark of S. L. Advani*

#### Corporate Headquarters

229, Pragati Industrial Estate, 316 N. M. Joshi Marg, Chinchpokli, Bombay - 400 011, INDIA.  
Tel. : +91.22.2300 0015  
Fax : +91.22.2307 3761

#### Sales and Service Centers

##### NEW BOMBAY

A-87, T.T.C. Indl. Area, M.I.D.C.,  
Thane Belapur Road, Khairne,  
New Bombay - 400 705, INDIA.  
Tel. : +91.22.2778 2492  
Fax : +91.22.2778 0339

##### PUNE

T-3, 3rd Floor, Plot No. 84,  
Survay No. 282, Tanagi Nagar,  
Chichwad Gaon,  
Pune - 400 033, INDIA.

##### BANGALORE

# 1835, 14th Cross,  
22nd Main, Sector - I,  
HSR layout,  
Bangalore - 560 034, INDIA.

#### Product Development Center

W-224, T.T.C. Indl. Area, M.I.D.C, Thane Belapur Road, Khairne, New Bombay - 400 705, INDIA.  
Tel. : +91.22.2778 1934  
Fax : +91.22.2778 0339

#### Plants

5 & 18, Rashmi Indl. Estate No.1,  
Vasai Road (East),  
Dist. Thane - 401 202, INDIA.  
Tel. : +91.250.2392021  
Fax : +91.250.2391576

42 & 43, Manish Indl. Estate No.5,  
Vasai Road (East),  
Dist. Thane - 401 202, INDIA.

9 & 14, Rashmi Indl. Estate No.1,  
Vasai Road (East),  
Dist. Thane - 401 202, INDIA.

#### Global Branch Offices

- Houston, Texas (USA)
- Casselman, Ontario (Canada)
- Schmallenberg (Germany)
- Sharjah (UAE)
- St. Louis, Missouri (USA)
- Edmonton, Alberta (Canada)
- Kuala Lumpur (Malaysia)

**Distribution available in over 110 countries worldwide.**

# INDEX

## CONDENSER / HEAT EXCHANGER TUBE EXPANDERS

PAGE 3-18

Generation II Series Condenser Tube Expanders  
Why do more prefer POWERMASTER ?  
AN Series  
900 Series  
1300 Series, AL Series  
800 Series  
800-5 Series  
1200 Series  
1200-5 Series  
8012 Series  
Special Tube Expanders  
Lube-A-Tube



## TUBE ROLLING CONTROLS

PAGE 19-30

Electric Tube Expansion Systems  
Hydraulic Thrust Expansion System  
Hydraulic Tube Expansion Systems (Hydex)  
Rolling Drives



## TUBE INSTALLATION TOOLS

PAGE 31-44

Serrating / Grooving Tool - 'ST' Series  
Serrating / Grooving Tool - 'NW' Series  
Serrating / Grooving Tool - 'SGT' Series  
Tube Sheet Hole Reamer  
Tube End Facer 'TEF' Series  
Tube End Facer 'FB' Series  
Tube End Facer 'FC' Series  
Flaring Tool  
Tube Sheet Hole Radius Cutter  
Tube Sheet Hole Brush, Tube Guide  
Tube Leak Detector Kit and Joint Testing Kit  
Tube End Facing Machine  
Tube Bundle Inserter



## TUBE REMOVAL TOOLS

PAGE 45-60

Air / Hydraulic Stub Puller  
Continuous Hydraulic Tube Puller  
Auto Stub Puller  
Tube Removal Tools  
Push Type Internal Tube Cutter - ATP  
Internal Tube Cutter - PR-68  
One Revolution Internal Tube Cutter - OTC  
Manual Tube Puller  
Tube Plugs  
Tube Bundle Extractors



# INDEX

## BOILER TUBE EXPANDERS

PAGE 61-92

Generation II Series Boiler Tube Expanders  
Why POWERMASTER Boiler Tube Expanders?  
114 Series  
A Series  
AF3 Series  
AB Series  
ABF3 Series  
P-1000 Series  
P-3000 Series  
Combination Beading Expanders  
SB Series for Sugar Mills  
Long Reach CSB For Sugar Mills  
Mandrel Drives  
Gear Drives  
Boiler Tube Expanding Accessories  
Lube-A-Tube



## TUBE CLEANERS

PAGE 93-116

Electric Tube Cleaners (1/4" I.D. & UP)  
Pneumatic Tube Cleaners (1/4" I.D. & UP)  
Electric Tube Cleaning Systems (1/4" I.D. & UP)  
Portable Pneumatic Tube Cleaners (1/4" - 1" I.D.)  
Portable Electric Tube Cleaners (1/4" - 1" I.D.)  
Portable Electric Tube Cleaning Systems (1/4" - 1" I.D.)  
Flexible Shafts (1/4" - 1" I.D.)  
Brushes (1/4" - 1" I.D.)  
Color Coded Shoot Thru Scrubbers (1/2" - 1" I.D.)  
Cleaning Accessories (1/4" - 1" I.D.)  
Shafts & Brushes (1" I.D. & UP)  
Brushes & Accessories (1" I.D. & UP)  
Cleaning Accessories (1" I.D. & UP)  
Shaft Repair  
Portable Pneumatic Tube Cleaners  
Sugar Mill Tube Cleaners  
Sugar Mill Wire Brushes  
Sugar Mill Cutter Heads  
Tube Cleaner Selection Guide





# CONDENSER / HEAT EXCHANGER TUBE EXPANDERS

Page 3-18



# GENERATION II SERIES CONDENSER TUBE EXPANDERS

## Features :

- Several improvements in the design and manufacture of tube expanders have been pioneered by Powermaster.
- The New Generation II series Condenser Tube Expanders will outlast any other manufacturers expanders! Guaranteed! Please contact us for warranty information.
- Powermaster expanders are competitively priced due to high production volumes and will offer you the best value for money by a long margin!
- Powermaster Generation II series Condenser Tube Expanders is the preferred tool of choice at over 3000 companies worldwide!

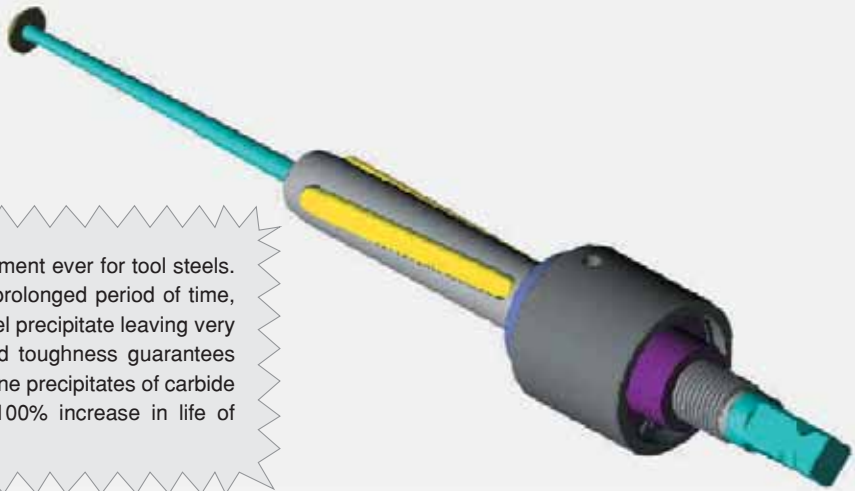

CRYOGENIC process - the best treatment ever for tool steels. This is a deep chilling treatment for prolonged period of time, which makes the alloy carbides in steel precipitate leaving very tough matrix of martensite. Increased toughness guarantees resilience to abnormal shocks, while fine precipitates of carbide reduce wear. Experience suggests 100% increase in life of the tool.

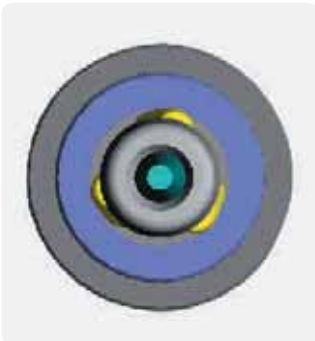

Optimal roll alignment for fast rolling. Maximum roll to tube contact reducing spring back effect. Equal load distribution leading to extended expander life.



CNC machined cages give Precision guiding to rolls during expansion.



One piece constructed mandrel on all models mates with well contoured rolls to give un-bridged smooth expanded tube.

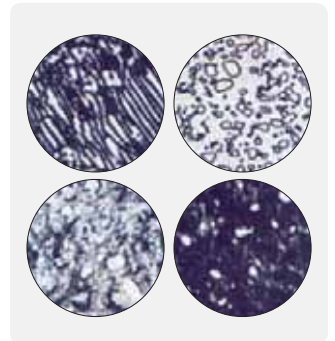

State of the art cryogenic and heat treatment facility guarantees best grain structure in both pre-machined and finished forms.



Dual purpose collars with reversible nose to expand tubes flush with tube sheet and tubes projecting from tube sheet.



Highest quality bearings eliminate heat due to friction.



Double radius rolls for easy long reach step rolling, supplied standard on all models.



Use of high end solid modeling design and finite element analysis software optimize results and eliminate design & assembly flaws.

# Why do more prefer **POWERMASTER?**

**Value :** In the competitive world of today, savings matter! You get the life of the tools you expect at a very competitive price.

**Quality :** Large percentage of our revenues are spent in improving designs and life of our products. New innovations on products in this catalogue are worlds firsts - **ONLY WITH POWERMASTER.**

**Service :** Powermaster is one of the worlds top volume producers of tube tools. This enables us to stock more and service more customers from stock. If your local distributor does not have a part in stock we can usually get it to you by courier in 3 - 4 days - **ANYWHERE IN THE WORLD.**

**Certification :** Powermaster facilities are certified to ISO-9002 by KPMG, USA. Most products manufactured conform to European CE directives.

**History :** You need experience to handle this vast array of products. We have been in the business since 1971!

## TYPES OF THRUST COLLAR FOR CONDENSER TUBE EXPANDERS

### REVERSIBLE THRUST COLLAR ASSEMBLY

COLLAR WITH FLUSH FACE

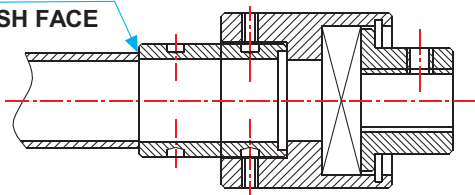

COLLAR WITH FIX RECESS

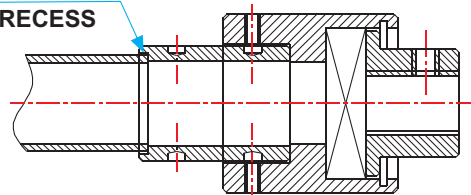

Nose portion can be 'reversed' to expand tubes flush with tube sheet and also tubes that are projecting 1/8" from tube sheet. This collar is supplied standard on all tube expanders.

### THIN WALL THRUST COLLARS

SPRING LOADED SPLIT COLLAR

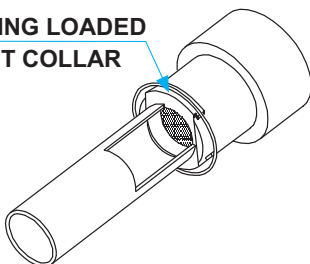

SPRING LOADED SPLIT COLLAR

Has an expandable front nose that expands along with the rolls, and eliminates tube being sucked into the collar.

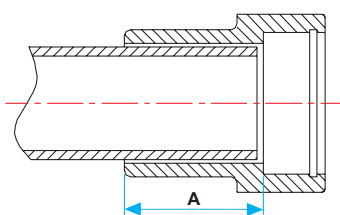

FULL RECESS THRUST COLLAR

Used when tubes project varying distances from the tube sheet.

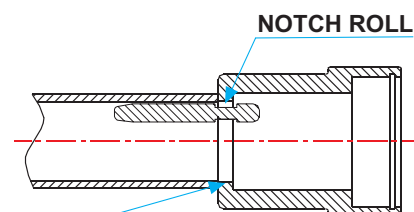

NOTCH ROLL THRUST COLLAR

This portion of the collar fits into the 'notched' portions of the special rolls supplied. This prevents thin walled tubes being sucked into the expander while expanding and has proven to be the most efficient method to eliminate this problem. Exact tube sheet thickness needs to be known for rolls to be specially designed.

1/4" - 3/8"  
O.D.

AN SERIES

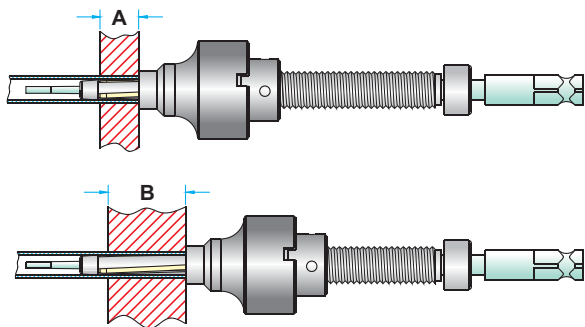

FOR TUBES INTERNAL DIAMETER  
FROM (3.8 mm) .152" TO (8.4 mm) .331"

TUBE EXPANDER FITTED WITH ROLLER LENGTH	FOR TUBE SHEET ADJUSTABLE RANGE	
	MINIMUM A	MAXIMUM B
(25.4mm) 1"	(6.35mm) 1/4"	(25.4mm) 1"

- Use : Oil Coolers, Radiators and other apparatus with small diameter tubes.
- Advantages : Captive mandrel - eliminates nut on mandrel tip which prevents scratching of tube I.D.
- Increased feed angle makes it the fastest operating tool on the market, ideal for high production environments.

Tube O.D. (mm) inch	Tube Thickness			Tube I.D.		Minimum I.D. Tool Enters		Maximum Expansion of Tool		EXPANDER with (25.4 mm) 1" Long Rollers		
	bwg	mm	inch	mm	inch	mm	inch	mm	inch	Complete Tool No.	Mandrel No.	Rollers Set. No.
6.35 1/4	18	1.24	.049	3.8	.152	3.7	.148	4.2	.167	A-25018	M-21819	R-20018
	19	1.06	.042	4.2	.166	4.0	.160	4.5	.180	A-25019	M-21819	R-21920
	20	0.88	.035	4.5	.180	4.4	.175	4.9	.196	A-25020	M-22021	R-21920
	21	0.81	.032	4.7	.186	4.5	.180	5.1	.202	A-25021	M-22021	R-22124
	22	0.71	.028	4.9	.194	4.8	.190	5.4	.213	A-25022	M-20022	R-22124
	23	0.63	.025	5.0	.200	4.9	.195	5.5	.216	A-25023	M-22324	R-21920
	24	0.55	.022	5.2	.206	5.1	.201	5.7	.224	A-25024	M-22324	R-22124
	28	0.35	.014	5.6	.222	5.4	.217	6.1	.243	A-25028	M-22830	R-22830
	29	0.33	.013	5.7	.224	5.4	.217	6.1	.243	A-25028	M-22830	R-22830
30	0.30	.012	5.7	.226	5.4	.217	6.1	.243	A-25028	M-22830	R-22830	
9.53 3/8	14	2.10	.083	5.3	.209	5.1	.204	5.8	.230	A-37514	M-22830-B	R-21920
	15	1.82	.072	5.8	.231	5.6	.225	6.6	.265	A-37515	M-22830-B	R-31516
	16	1.65	.065	6.2	.245	6.0	.238	7.0	.278	A-37516	M-31617	R-31516
	17	1.47	.058	6.5	.259	6.4	.253	7.4	.293	A-37517	M-31617	R-31720
	18	1.24	.049	7.0	.277	6.8	.270	7.8	.310	A-37518	M-30018	R-31720
	19	1.06	.042	7.3	.291	7.1	.285	8.1	.325	A-37519	M-30019	R-31720
	20	0.88	.035	7.7	.305	7.4	.295	8.4	.335	A-37520	M-32021	R-31720
	21	0.81	.032	7.9	.311	7.5	.305	8.6	.345	A-37521	M-32021	R-32122
	22	0.71	.028	8.1	.319	7.9	.312	8.9	.353	A-37522	M-32224	R-32122
23	0.63	.025	8.2	.325	8.1	.318	9.2	.363	A-37523	M-32224	R-32324	
24	0.55	.022	8.4	.331	8.1	.318	9.2	.363	A-37523	M-32224	R-32324	

Note : All 'AN' series expanders come with 1/4" square mandrel drives. Round mandrel drives are optional.



# 900 SERIES

1/4" - 3/8"  
O.D.

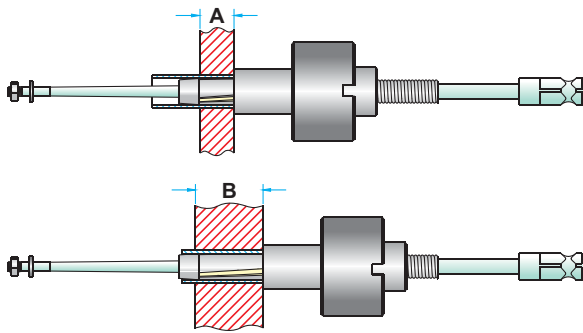

FOR TUBES INTERNAL DIAMETER  
FROM (3.8 mm) .152" TO (8.4 mm) .331"

TUBE EXPANDERS FITTED WITH ROLLER LENGTH	FOR TUBE SHEET ADJUSTABLE RANGE	
	MINIMUM A	MAXIMUM B
(19.05mm) 3/4"	(6.35mm) 1/4"	(19.05mm) 3/4"
(31.75mm) 1.1/4"	(19.05mm) 3/4"	(31.75mm) 1.1/4"

- Use : Oil Coolers, Radiators and other apparatus with small diameter tubes.
- This tool has been the workhorse for several years for use on small diameter tubes.

Tube O.D. (mm) inch	Tube Thickness			Tube I.D.		Minimum I.D. Tool Enters		Maximum Expansion of Tool		EXPANDER with (19.05 mm) 3/4" Long Rollers			EXPANDER with (31.75 mm) 1.1/4" Long Rollers		
	bwg	mm	inch	mm	inch	mm	inch	mm	inch	Complete Tool No.	Mandrel No.	Rollers Set. No.	Complete Tool No.	Mandrel No.	Rollers Set. No.
(6.35) 1/4	20	0.88	.035	4.5	.180	4.4	.175	5.1	.200	923	M-40	923	-	-	-
	21	0.81	.032	4.7	.186	4.5	.180	5.2	.207	924	M-40	924	-	-	-
	22	0.71	.028	4.9	.194	4.8	.190	5.5	.216	925	M-41	925	-	-	-
	23	0.63	.025	5.0	.200	4.9	.195	5.6	.222	926	M-41	923	-	-	-
	24	0.55	.022	5.2	.206	5.1	.201	5.8	.230	927	M-41	924	-	-	-
	28	0.35	.014	5.6	.222	5.6	.222	6.0	.238	928	928	903	-	-	-
	29	0.33	.013	5.7	.224	5.6	.222	6.0	.238	928	928	903	-	-	-
(9.53) 3/8	30	0.30	.012	5.7	.226	5.6	.222	6.0	.238	928	928	903	-	-	-
	14	2.10	.083	5.3	.209	5.1	.201	5.8	.232	927	M-41	924	-	-	-
	15	1.82	.072	5.8	.231	5.8	.230	6.7	.265	915	M-42	903	-	-	-
	16	1.65	.065	6.2	.245	6.1	.240	6.9	.275	916	M-36	916	916 L	M-36 L	916 L
	17	1.47	.058	6.5	.259	6.4	.255	7.3	.289	918	M-38	903	920	M-38	904
	18	1.24	.049	7.0	.277	6.9	.272	7.8	.307	901	M-30	903	902	M-30	904
	19	1.06	.042	7.3	.291	7.2	.286	8.1	.320	903	M-31	903	904	M-31	904
	20	0.88	.035	7.7	.305	7.6	.300	8.4	.334	905	M-32	907	906	M-32	908
	21	0.81	.032	7.9	.311	7.7	.306	8.6	.340	907	M-33	907	908	M-33	908
	22	0.71	.028	8.1	.319	7.9	.314	8.8	.349	909	M-34	909	910	M-34	910
3/8	23	0.63	.025	8.2	.325	8.1	.320	9.0	.357	911	M-34	911	912	M-34	912
	24	0.55	.022	8.4	.331	8.1	.320	9.0	.357	911	M-34	911	912	M-34	912

Note : All '900' series expanders come with 1/4" square mandrel drives. Round mandrel drives are optional.



**1300 SERIES**

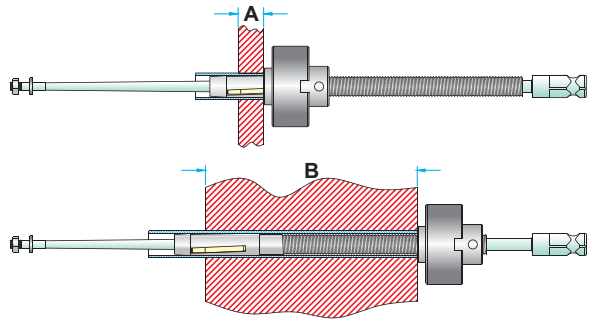

FOR TUBES INTERNAL DIAMETER FROM (5.8 mm) .231" TO (8.4 mm) .331"

TUBE EXPANDERS FITTED WITH ROLLER LENGTH	FOR TUBE SHEET ADJUSTABLE RANGE	
	MINIMUM A	MAXIMUM B
(19.05mm) 3/4"	(19.05mm) 3/4"	(76.20mm) 3"
(31.75mm) 1.1/4"	(31.75mm) 1.1/4"	(88.90mm) 3.1/2"

• Use : Oil Coolers, Radiators and other apparatus with small diameter tubes and thick tube sheets.

Tube O.D. (mm) inch	Tube Thickness			Tube I.D.		Minimum I.D. Tool Enters		Maximum Expansion of Tool		EXPANDER with (19.05 mm) 3/4" Long Rollers			EXPANDER with (31.75 mm) 1.1/4" Long Rollers		
	bwg	mm	inch	mm	inch	mm	inch	mm	inch	Complete Tool No.	Mandrel No.	Rollers Set. No.	Complete Tool No.	Mandrel No.	Rollers Set. No.
(9.53) 3/8	15	1.82	.072	5.8	.231	5.8	.230	6.7	.265	1315	M-86	1315	1316	M-86	1316
	16	1.65	.065	6.2	.245	6.1	.240	6.9	.275	1319	M-86	916	1319 L	M-86	916 L
	17	1.47	.058	6.5	.259	6.4	.255	7.3	.289	1317	M-88	903	1318	M-88	904
	18	1.24	.049	7.0	.277	6.9	.272	7.8	.307	1301	M-80	903	1302	M-80	904
	19	1.06	.042	7.3	.291	7.2	.286	8.1	.320	1303	M-81	903	1304	M-81	904
	20	0.88	.035	7.7	.305	7.6	.300	8.4	.334	1305	M-82	907	1306	M-82	908
	21	0.81	.032	7.9	.311	7.7	.306	8.6	.340	1307	M-83	907	1308	M-83	908
	22	0.71	.028	8.1	.319	7.9	.314	8.8	.349	1309	M-84	909	1310	M-84	910
23	0.63	.025	8.2	.325	8.1	.320	9.0	.357	1311	M-84	911	1312	M-84	912	
24	0.55	.022	8.4	.331	8.1	.320	9.0	.357	1311	M-84	911	1312	M-84	912	

**Note :** All '1300' series expanders come with 1/4" square mandrel drives. Round mandrel drives are optional.

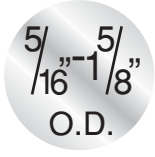

**AL SERIES**

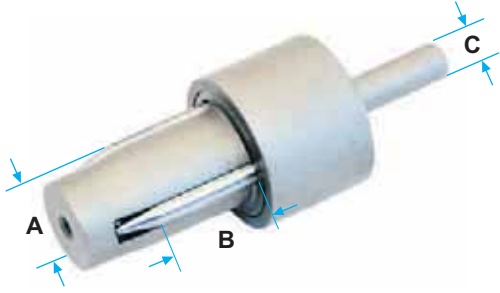

This Expander is used to enlarge the ends of soft tube so that another tube of same size can be inserted into the expanded section and soldered for a leak proof joint. These Expanders are designed to leave 0.015" clearance for slip fit and soldering. Special sizes and shanks on order. Average depth of expansion is 3/4". Specify tube gauge on order.

Tube O.D.		Expander No.	Rollers Set No.	A		B		C	
mm	inch			mm	inch	mm	inch	mm	inch
7.93	5/16	AL-312	ALR-312	8.38	0.33	15.87	5/8	6.35	1/4
9.53	3/8	AL-375	ALR-375	9.90	0.39	15.87	5/8	6.35	1/4
11.11	7/16	AL-407	ALR-407	11.43	0.45	15.87	5/8	7.93	5/16
12.70	1/2	AL-500	ALR-500	13.20	0.52	15.87	5/8	7.93	5/16
14.28	9/16	AL-562	ALR-562	14.73	0.58	19.05	3/4	7.93	5/16
15.87	5/8	AL-625	ALR-625	16.25	0.64	19.05	3/4	7.93	5/16
19.05	3/4	AL-750	ALR-750	19.55	0.77	19.05	3/4	9.52	3/8
22.22	7/8	AL-875	ALR-875	22.60	0.89	19.05	3/4	9.52	3/8
25.40	1	AL-1000	ALR-1000	25.65	1.01	25.40	1	9.52	3/8
28.57	1.1/8	AL-1125	ALR-1125	28.95	1.14	25.40	1	12.70	1/2
31.75	1.1/4	AL-1250	ALR-1250	32.25	1.27	25.40	1	12.70	1/2
34.92	1.3/8	AL-1375	ALR-1375	35.30	1.39	25.40	1	12.70	1/2
38.10	1.1/2	AL-1500	ALR-1500	38.60	1.52	25.40	1	12.70	1/2
41.27	1.5/8	AL-1625	ALR-1625	41.65	1.64	25.40	1	14.28	9/16

**Note :** All 'AL' series expanders are supplied with round mandrel drives.

# 800 SERIES

1/2"-1 1/2"  
O.D.

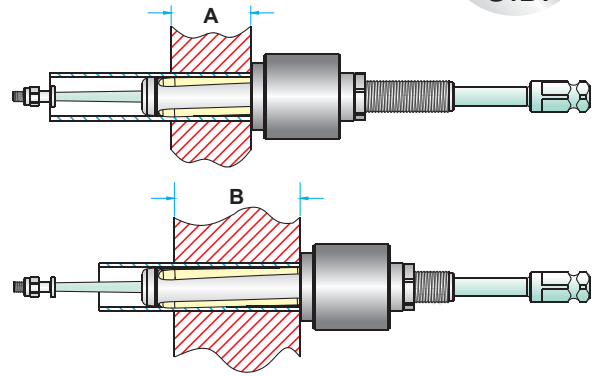

FOR TUBES INTERNAL DIAMETER  
FROM (8.4 mm) .334" TO (36.3 mm) 1.43"

**Use : Most popular tool worldwide  
for use on heat exchangers and condensers  
with tubes of 1/2"-1.1/2" O.D.**

TUBE EXPANDERS FITTED WITH ROLLER LENGTH	FOR TUBE SHEET ADJUSTABLE RANGE	
	MINIMUM A	MAXIMUM B
(38.1mm) 1.1/2"	(12.7mm) 1/2"	(38.1mm) 1.1/2"
(57.1mm) 2.1/4"	(31.7mm) 1.1/4"	(57.1mm) 2.1/4"

Tube O.D. (mm) inch	Tube Thickness			Tube I.D.		Minimum I.D. Tool Enters		Maximum Expansion of Tool		EXPANDER with (38.10 mm) 1.1/2" Long Rollers			EXPANDER with (57.15 mm) 2.1/4" Long Rollers		
	bwg	mm	inch	mm	inch	mm	inch	mm	inch	Complete Tool No.	Mandrel No.	Rollers Set. No.	Complete Tool No.	Mandrel No.	Rollers Set. No.
(12.70)  1/2	14	2.10	.083	8.4	.334	8.2	.324	9.5	.374	797	797	797	-	-	-
	15	1.82	.072	9.0	.356	8.8	.348	10.1	.398	799	799	R-1	-	-	-
	16	1.65	.065	9.4	.370	9.1	.360	10.4	.410	801	M-1	R-1	-	-	-
	17	1.47	.058	9.7	.384	9.5	.374	10.7	.424	803	M-1	R-2	-	-	-
	18	1.24	.049	10.2	.402	9.9	.392	11.3	.447	805	M-2	R-3	-	-	-
	20	0.88	.035	10.9	.430	10.3	.406	11.7	.461	805 S	M-3	R-3	-	-	-
(15.88)  5/8	12	2.76	.109	10.3	.407	9.9	.392	11.3	.447	805	M-2	R-3	-	-	-
	13	2.41	.095	11.0	.435	10.8	.425	12.1	.480	807	M-3	R-4	-	-	-
	14	2.10	.083	11.6	.459	11.4	.449	12.9	.509	809	M-4	R-4	810	M-4	R-4-A
	15	1.82	.072	12.2	.481	11.9	.471	13.6	.536	811	M-5	R-5	812	M-5	R-5-A
	16	1.65	.065	12.5	.495	12.3	.485	13.9	.550	813	M-5	R-6	814	M-5	R-6-A
	17	1.47	.058	12.9	.509	12.6	.499	14.3	.564	815	M-6	R-6	816	M-6	R-6-A
	18	1.24	.049	13.3	.527	13.1	.517	14.5	.572	817	M-7	R-7	818	M-7	R-7-A
	19	1.06	.042	13.7	.541	13.2	.522	14.7	.582	819	M-6	R-7	820	M-6	R-7-A
	20	0.88	.035	14.1	.555	13.6	.536	15.1	.596	819 S	M-8	R-7	820 S	M-8	R-7-A
	21	0.81	.032	14.2	.561	13.6	.536	15.1	.596	819 S	M-8	R-7	820 S	M-8	R-7-A
	22	0.71	.028	14.4	.569	13.6	.536	15.1	.596	819 S	M-8	R-7	820 S	M-8	R-7-A
(19.05)  3/4	10	3.40	.134	12.2	.482	11.9	.471	13.6	.536	811	M-5	R-5	812	M-5	R-5-A
	11	3.04	.120	12.9	.510	12.6	.499	14.3	.564	815	M-6	R-6	816	M-6	R-6-A
	12	2.76	.109	13.5	.532	13.2	.522	14.7	.582	819	M-6	R-7	820	M-6	R-7-A
	13	2.41	.095	14.2	.560	13.9	.550	15.6	.615	821	M-8	R-8	822	M-8	R-8-A
	14	2.10	.083	14.8	.584	14.5	.574	16.2	.639	823	M-8	R-9	824	M-8	R-9-A
	15	1.82	.072	15.3	.606	15.1	.596	16.7	.661	825	M-8	R-10	826	M-8	R-10-A
	16	1.65	.065	15.7	.620	15.3	.605	17.4	.685	827	M-9	R-10	828	M-9	R-10-A
	17	1.47	.058	16.1	.634	15.7	.619	17.7	.699	829	M-9	R-11	830	M-9	R-11-A
	18	1.24	.049	16.5	.652	15.7	.619	17.7	.699	829	M-9	R-11	830	M-9	R-11-A
	19	1.06	.042	16.9	.666	16.3	.642	18.3	.722	831	M-9	R-12	832	M-9	R-12-A
	20	0.88	.035	17.2	.680	16.3	.642	18.3	.722	831	M-9	R-12	832	M-9	R-12-A
	21	0.81	.032	17.4	.686	16.3	.642	18.3	.722	831	M-9	R-12	832	M-9	R-12-A
	22	0.71	.028	17.6	.694	16.3	.642	18.3	.722	831	M-9	R-12	832	M-9	R-12-A
(22.22)  7/8	10	3.40	.134	15.4	.607	15.1	.596	16.7	.661	825	M-8	R-10	826	M-8	R-10-A
	11	3.04	.120	16.1	.635	15.7	.619	17.7	.699	829	M-9	R-11	830	M-9	R-11-A
	12	2.76	.109	16.6	.657	16.3	.642	18.3	.722	831	M-9	R-12	832	M-9	R-12-A
	13	2.41	.095	17.4	.685	17.0	.670	19.0	.750	833	M-10	R-13	834	M-10	R-13-A
	14	2.10	.083	18.0	.709	17.4	.685	19.6	.774	835	M-11	R-14	836	M-11	R-14-A
	15	1.82	.072	18.5	.731	18.0	.712	20.3	.801	837	M-11	R-15	838	M-11	R-15-A
	16	1.65	.065	18.9	.745	18.4	.726	20.7	.815	839	M-12	R-15	840	M-12	R-15-A
	17	1.47	.058	19.2	.759	18.8	.740	21.0	.829	843	M-12	R-16	844	M-12	R-16-A
	18	1.24	.049	19.7	.777	18.8	.740	21.0	.829	843	M-12	R-16	844	M-12	R-16-A

Model 797-856 expanders come with 3/8" square mandrel drives and Model 857-900 expanders come with 1/2" square mandrel drives.

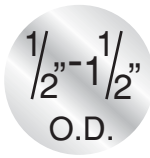

800 SERIES

Tube O.D. (mm) inch	Tube Thickness			Tube I.D.		Minimum I.D. Tool Enters		Maximum Expansion of Tool		EXPANDER with (38.10 mm) 1.1/2" Long Rollers			EXPANDER with (57.15 mm) 2.1/4" Long Rollers		
	bwg	mm	inch	mm	inch	mm	inch	mm	inch	Complete Tool No.	Mandrel No.	Rollers Set. No.	Complete Tool No.	Mandrel No.	Rollers Set. No.
1 (25.40)	8	4.19	.165	17.0	.670	16.6	.655	18.6	.735	841	M-9	R-13	842	M-9	R-13-A
	9	3.75	.148	17.8	.704	17.4	.685	19.6	.774	835	M-11	R-14	836	M-11	R-14-A
	10	3.40	.134	18.5	.732	18.0	.712	20.3	.801	837	M-11	R-15	838	M-11	R-15-A
	11	3.04	.120	19.3	.760	18.8	.740	21.0	.829	843	M-12	R-16	844	M-12	R-16-A
	12	2.76	.109	19.8	.782	19.3	.763	21.6	.852	845	M-12	R-17	846	M-12	R-17-A
	13	2.41	.095	20.5	.810	20.0	.791	22.3	.880	847	M-12	R-18	848	M-12	R-18-A
	14	2.10	.083	21.1	.834	20.5	.810	23.0	.909	849	M-13	R-18	850	M-13	R-18-A
	15	1.82	.072	21.7	.856	21.2	.837	23.7	.936	851	M-13	R-19	852	M-13	R-19-A
	16	1.65	.065	22.1	.870	21.2	.837	23.7	.936	851	M-13	R-19	852	M-13	R-19-A
	17	1.47	.058	22.4	.884	21.9	.865	24.4	.964	855	M-13	R-21	856	M-13	R-21-A
18	1.24	.049	22.9	.902	21.9	.865	24.4	.964	855	M-13	R-21	856	M-13	R-21-A	
19	1.06	.042	23.2	.916	21.9	.865	24.4	.964	855	M-13	R-21	856	M-13	R-21-A	
20	0.88	.035	23.6	.930	21.9	.865	24.4	.964	855	M-13	R-21	856	M-13	R-21-A	
1.1/8 (28.58)	8	4.19	.165	20.1	.795	19.7	.776	22.2	.875	853	M-13	R-20	854	M-13	R-20-A
	9	3.75	.148	21.0	.829	20.5	.810	23.0	.909	849	M-13	R-18	850	M-13	R-18-A
	10	3.40	.134	21.7	.857	21.2	.837	23.7	.936	851	M-13	R-19	852	M-13	R-19-A
	11	3.04	.120	22.4	.885	21.9	.865	24.4	.964	855	M-13	R-21	856	M-13	R-21-A
	12	2.76	.109	23.0	.907	22.4	.883	24.9	.982	857	M-14	R-21	858	M-14	R-21-A
	13	2.41	.095	23.7	.935	23.2	.916	25.7	1.015	859	M-14	R-22	860	M-14	R-22-A
	14	2.10	.083	24.3	.959	23.7	.935	26.5	1.044	861	M-15	R-23	862	M-15	R-23-A
	15	1.82	.072	24.9	.981	24.4	.962	27.2	1.071	863	M-15	R-24	864	M-15	R-24-A
16	1.65	.065	25.2	.995	24.4	.962	27.2	1.071	863	M-15	R-24	864	M-15	R-24-A	
17	1.47	.058	25.6	1.010	25.1	.990	27.9	1.009	867	M-16	R-26	868	M-16	R-26-A	
18	1.24	.049	26.0	1.027	25.1	.990	27.9	1.009	867	M-16	R-26	868	M-16	R-26-A	
1.1/4 (31.75)	8	4.19	.165	23.3	.920	22.8	.901	25.6	1.010	865	M-15	R-25	866	M-15	R-25-A
	9	3.75	.148	24.2	.954	23.7	.935	26.5	1.044	861	M-15	R-23	862	M-15	R-23-A
	10	3.40	.134	24.9	.982	24.4	.962	27.2	1.071	863	M-15	R-24	864	M-15	R-24-A
	11	3.04	.120	25.6	1.010	25.1	.990	27.9	1.009	867	M-16	R-26	868	M-16	R-26-A
	12	2.76	.109	26.2	1.032	25.7	1.013	28.5	1.122	869	M-16	R-27	870	M-16	R-27-A
	13	2.41	.095	26.9	1.060	26.4	1.039	29.2	1.150	871	M-17	R-28	872	M-17	R-28-A
	14	2.10	.083	27.5	1.084	26.9	1.060	29.6	1.169	873	M-17	R-29	874	M-17	R-29-A
	15	1.82	.072	28.0	1.106	27.6	1.087	30.3	1.196	875	M-17	R-30	876	M-17	R-30-A
	16	1.65	.065	28.4	1.120	27.6	1.087	30.3	1.196	875	M-17	R-30	876	M-17	R-30-A
17	1.47	.058	28.8	1.134	28.3	1.115	31.0	1.224	879	M-18	R-30	880	M-18	R-30-A	
18	1.24	.049	29.2	1.152	28.3	1.115	31.0	1.224	879	M-18	R-30	880	M-18	R-30-A	
1.3/8 (34.92)	8	4.19	.165	26.5	1.045	26.0	1.026	28.8	1.135	877	M-17	R-31	878	M-17	R-31-A
	9	3.75	.148	27.4	1.079	26.9	1.060	29.6	1.169	873	M-17	R-29	874	M-17	R-29-A
	10	3.40	.134	28.1	1.107	27.6	1.087	30.3	1.196	875	M-17	R-30	876	M-17	R-30-A
	11	3.04	.120	28.8	1.135	28.3	1.115	31.0	1.224	879	M-18	R-30	880	M-18	R-30-A
	12	2.76	.109	29.3	1.157	28.7	1.133	31.5	1.242	881	M-18	R-32	882	M-18	R-32-A
	13	2.41	.095	30.1	1.185	29.4	1.160	32.3	1.275	883	M-19	R-33	884	M-19	R-33-A
	14	2.10	.083	30.7	1.209	29.9	1.179	32.8	1.294	885	M-20	R-34	886	M-20	R-34-A
15	1.82	.072	31.2	1.231	30.6	1.206	33.5	1.321	887	M-20	R-35	888	M-20	R-35-A	
16	1.65	.065	31.6	1.245	30.6	1.206	33.5	1.321	887	M-20	R-35	888	M-20	R-35-A	
1.1/2 (38.10)	8	4.19	.165	29.7	1.170	29.0	1.145	32.0	1.260	889	M-19	R-34	890	M-19	R-34-A
	9	3.75	.148	30.5	1.204	29.9	1.177	32.8	1.294	885	M-20	R-34	886	M-20	R-34-A
	10	3.40	.134	31.2	1.232	30.6	1.206	33.5	1.321	887	M-20	R-35	888	M-20	R-35-A
	11	3.04	.120	32.0	1.260	31.3	1.235	34.2	1.350	891	M-20	R-36	892	M-20	R-36-A
	12	2.76	.109	32.5	1.282	31.9	1.257	34.8	1.372	893	M-20	R-37	894	M-20	R-37-A
	13	2.41	.095	33.2	1.310	32.6	1.285	35.5	1.400	895	M-21	R-37	896	M-21	R-37-A
	14	2.10	.083	33.8	1.334	32.6	1.285	35.5	1.400	895	M-21	R-37	896	M-21	R-37-A
	15	1.82	.072	34.4	1.356	33.8	1.331	36.7	1.446	897	M-21	R-38	898	M-21	R-38-A
	16	1.65	.065	34.8	1.370	33.8	1.331	36.7	1.446	897	M-21	R-38	898	M-21	R-38-A
	17	1.47	.058	35.1	1.384	33.8	1.331	37.3	1.472	899	M-22	R-38	900	M-22	R-38-A
18	1.24	.049	35.6	1.402	33.8	1.331	37.3	1.472	899	M-22	R-38	900	M-22	R-38-A	
19	1.06	.042	35.9	1.416	33.8	1.331	37.3	1.472	899	M-22	R-38	900	M-22	R-38-A	
20	0.88	.035	36.3	1.430	33.8	1.331	37.3	1.472	899	M-22	R-38	900	M-22	R-38-A	

Model 797-856 expanders come with 3/8" square mandrel drives and Model 857-900 expanders come with 1/2" square mandrel drives.

# 800-5 SERIES FIVE ROLL FOR THIN WALL TUBES

5/8"-1 1/2"  
O.D.

800-5 SERIES

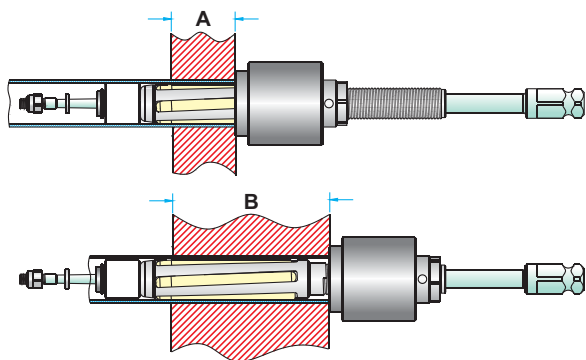

FOR TUBES INTERNAL DIAMETER  
FROM (12.9 mm) .509" TO (36.7 mm) 1.44"

TUBE EXPANDERS FITTED WITH ROLLER LENGTH	FOR TUBE SHEET ADJUSTABLE RANGE	
	MINIMUM A	MAXIMUM B
(38.1mm) 1.1/2"	(12.7mm) 1/2"	(38.1mm) 1.1/2"
(57.1mm) 2.1/4"	(31.7mm) 1.1/4"	(57.1mm) 2.1/4"

- Use : Highly recommended for use on thin walled tubes (19 thru 22 gauge walls) of Stainless Steel, Titanium, Incoloy and other exotic materials.
- Advantages : Gives a more concentric and even expansion when expanding thin walled tubes vs. a conventional 3 roll expander and reduces tube spring back effect.

Tube O.D. (mm) inch	Tube Thickness			Tube I.D.		Minimum I.D. Tool Enters		Maximum Expansion of Tool		EXPANDER with (38.10 mm) 1.1/2" Long Rollers			EXPANDER with (57.15 mm) 2.1/4" Long Rollers		
	bwg	mm	inch	mm	inch	mm	inch	mm	inch	Complete Tool No.	Mandrel No.	Rollers Set. No.	Complete Tool No.	Mandrel No.	Rollers Set. No.
5/8 (15.88)	17	1.47	.058	12.9	.509	12.6	.499	14.3	.564	815-5	816-5	R-4-5	816-5	816-5	R-4-A-5
	18	1.24	.049	13.4	.527	13.1	.517	14.6	.576	817-5	M-9	R-4-5	-	-	-
	19	1.06	.042	13.7	.541	13.3	.522	14.8	.582	819-5	820-5	R-4-5	820-5	820-5	R-4-A-5
	20	0.88	.035	14.1	.555	13.6	.536	15.1	.596	819-5 S	820-5 S	R-4-5	820-5 S	820-5 S	R-4-A-5
	21	0.81	.032	14.2	.561	13.6	.536	15.1	.596	819-5 S	820-5 S	R-4-5	820-5 S	820-5 S	R-4-A-5
	22	0.71	.028	14.5	.569	13.6	.536	15.1	.596	819-5 S	820-5 S	R-4-5	820-5 S	820-5 S	R-4-A-5
3/4 (19.05)	13	2.41	.095	14.2	.560	13.9	.550	15.6	.615	821-5	822-5	R-5-5	822-5	822-5	R-5-A-5
	14	2.10	.083	14.8	.584	14.5	.574	15.9	.629	823-5	824-5	R-6-5	824-5	824-5	R-6-A-5
	15	1.82	.072	15.3	.606	14.9	.590	16.8	.661	825-5	826-5	R-7-5	826-5	826-5	R-7-A-5
	16	1.65	.065	15.7	.620	15.3	.605	17.2	.680	827-5	M-13	R-7-5	828-5	M-13	R-7-A-5
	17	1.47	.058	16.1	.634	15.7	.619	17.8	.699	829-5	830-5	R-7-5	830-5	830-5	R-7-A-5
	18	1.24	.049	16.5	.652	15.7	.619	17.8	.699	829-5	830-5	R-7-5	830-5	830-5	R-7-A-5
	19	1.06	.042	16.9	.666	16.3	.642	18.5	.729	831-5	M-13	R-9-5	832-5	M-13	R-9-A-5
	20	0.88	.035	17.2	.680	16.3	.642	18.5	.729	831-5	M-13	R-9-5	832-5	M-13	R-9-A-5
	21	0.81	.032	17.4	.686	16.3	.642	18.5	.729	831-5	M-13	R-9-5	832-5	M-13	R-9-A-5
	22	0.71	.028	17.6	.694	16.3	.642	18.5	.729	831-5	M-13	R-9-5	832-5	M-13	R-9-A-5
	23	0.64	.025	17.8	.700	17.0	.670	18.9	.747	833-5	M-14-3/8	R-9-5	834-5	M-14-3/8	R-9-A-5
	24	0.56	.022	17.9	.706	17.0	.670	18.9	.747	833-5	M-14-3/8	R-9-5	834-5	M-14-3/8	R-9-A-5
25	0.51	.020	18.0	.710	17.4	.685	19.0	.750	835-5	M-15-3/8	R-10-5	836-5	M-15-3/8	R-10-A-5	

For best results a 'Thin Wall Thrust Collar' should be used when rolling 19 thru 22 gauge wall tubes. (See Pg. 5)

Model 815-5 - 858-5 come with 3/8" square mandrel drives and Model 859-5 - 900-5 come with 1/2" square mandrel drives.

www.tubeexpanders.com

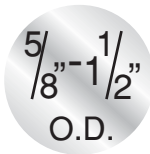

800-5 SERIES FIVE ROLL FOR THIN WALL TUBES

Tube O.D. (mm) inch	Tube Thickness			Tube I.D.		Minimum I.D. Tool Enters		Maximum Expansion of Tool		EXPANDER with (38.10 mm) 1.1/2" Long Rollers			EXPANDER with (57.15 mm) 2.1/4" Long Rollers		
	bwg	mm	inch	mm	inch	mm	inch	mm	inch	Complete Tool No.	Mandrel No.	Rollers Set. No.	Complete Tool No.	Mandrel No.	Rollers Set. No.
(22.22) 7/8	13	2.41	.095	17.4	.685	17.0	.670	18.9	.747	833-5	M-14-3/8	R-9-5	834-5	M-14-3/8	R-9-A-5
	14	2.10	.083	18.0	.709	17.4	.685	19.0	.750	835-5	M-15-3/8	R-10-5	836-5	M-15-3/8	R-10-A-5
	16	1.65	.065	18.9	.745	18.4	.726	20.3	.800	839-5	840-5	R-11-5	840-5	840-5	R-11-A-5
	17	1.47	.058	19.2	.759	18.8	.740	20.9	.824	843-5	M-17-3/8	R-11-5	844-5	M-17-3/8	R-11-A-5
	18	1.24	.049	19.7	.777	18.8	.740	20.9	.824	843-5	M-17-3/8	R-11-5	844-5	M-17-3/8	R-11-A-5
	19	1.07	.042	20.1	.791	19.4	.763	21.6	.851	845-5	M-18-3/8	R-11-5	846-5	M-18-3/8	R-11-A-5
	20	0.89	.035	20.4	.805	19.4	.763	21.6	.851	845-5	M-18-3/8	R-11-5	846-5	M-18-3/8	R-11-A-5
	21	0.81	.032	20.6	.811	19.4	.763	21.6	.851	845-5	M-18-3/8	R-11-5	846-5	M-18-3/8	R-11-A-5
	22	0.71	.028	20.8	.819	19.4	.763	21.6	.851	845-5	M-18-3/8	R-11-5	846-5	M-18-3/8	R-11-A-5
	23	0.64	.025	20.9	.825	20.1	.791	22.4	.880	847-5	M-18-3/8	R-13-5	848-5	M-18-3/8	R-13-A-5
24	0.56	.022	21.1	.831	20.1	.791	22.4	.880	847-5	M-18-3/8	R-13-5	848-5	M-18-3/8	R-13-A-5	
(25.40) 1	12	2.76	.109	19.8	.782	19.4	.763	21.6	.852	845-5	M-18-3/8	R-11-5	846-5	M-18-3/8	R-11-A-5
	13	2.41	.095	20.5	.810	20.1	.791	22.4	.880	847-5	M-18-3/8	R-13-5	848-5	M-18-3/8	R-13-A-5
	14	2.10	.083	21.2	.834	20.5	.810	22.3	.879	849-5	850-5	R-12-5	850-5	850-5	R-12-A-5
	15	1.82	.072	21.7	.856	21.3	.837	23.8	.936	851-5	852-5	R-13-5	852-5	852-5	R-13-A-5
	16	1.65	.065	22.0	.870	21.3	.837	23.8	.936	851-5	852-5	R-13-5	852-5	852-5	R-13-A-5
	17	1.47	.058	22.4	.884	22.0	.865	24.5	.965	855-5	856-5	R-13-5	856-5	856-5	R-13-A-5
	18	1.24	.049	22.9	.902	22.0	.865	24.5	.965	855-5	856-5	R-13-5	856-5	856-5	R-13-A-5
	19	1.06	.042	23.2	.916	22.0	.865	24.5	.965	855-5	856-5	R-13-5	856-5	856-5	R-13-A-5
	20	0.88	.035	23.6	.930	22.0	.865	24.5	.965	855-5	856-5	R-13-5	856-5	856-5	R-13-A-5
	21	0.81	.032	23.8	.936	22.4	.883	25.3	.997	857-5	M-21-3/8	R-15-5	858-5	M-21-3/8	R-15-A-5
	22	0.71	.028	24.0	.944	22.4	.883	25.3	.997	857-5	M-21-3/8	R-15-5	858-5	M-21-3/8	R-15-A-5
	23	0.64	.025	24.1	.950	22.4	.883	25.3	.997	857-5	M-21-3/8	R-15-5	858-5	M-21-3/8	R-15-A-5
24	0.56	.022	24.3	.956	22.4	.883	25.3	.997	857-5	M-21-3/8	R-15-5	858-5	M-21-3/8	R-15-A-5	
25	0.51	.020	24.4	.960	22.4	.883	25.3	.997	857-5	M-21-3/8	R-15-5	858-5	M-21-3/8	R-15-A-5	
(28.58) 1.1/8	12	2.76	.109	23.0	.907	22.4	.883	25.3	.997	857-5	M-21-3/8	R-15-5	858-5	M-21-3/8	R-15-A-5
	13	2.41	.095	23.7	.935	23.2	.916	25.4	1.000	859-5	860-5	R-16-5	860-5	860-5	R-16-A-5
	14	2.11	.083	24.3	.959	23.7	.935	26.4	1.039	861-5	862-5	R-17-5	862-5	862-5	R-17-A-5
	22	0.71	.028	27.2	1.069	26.4	1.039	29.4	1.157	871-5	872-5	R-19-5	872-5	872-5	R-19-A-5
	24	0.56	.022	27.5	1.081	26.4	1.039	29.4	1.157	871-5	872-5	R-19-5	872-5	872-5	R-19-A-5
(31.75) 1.1/4	15	1.82	.072	28.1	1.106	27.6	1.087	30.4	1.196	875-5	876-5	R-21-5	876-5	876-5	R-21-A-5
	16	1.65	.065	28.4	1.120	27.6	1.087	30.4	1.196	875-5	876-5	R-21-5	876-5	876-5	R-21-A-5
	17	1.47	.058	28.8	1.134	28.3	1.115	31.3	1.231	879-5	880-5	R-21-5	880-5	880-5	R-21-A-5
	18	1.24	.049	29.3	1.152	28.3	1.115	31.3	1.231	879-5	880-5	R-21-5	880-5	880-5	R-21-A-5
	19	1.07	.042	29.6	1.166	28.3	1.115	31.3	1.231	879-5	880-5	R-21-5	880-5	880-5	R-21-A-5
	20	0.88	.035	30.0	1.180	28.3	1.115	31.3	1.231	879-5	880-5	R-21-5	880-5	880-5	R-21-A-5
	21	0.81	.032	30.1	1.186	28.3	1.115	31.3	1.231	879-5	880-5	R-21-5	880-5	880-5	R-21-A-5
	22	0.71	.028	30.3	1.194	28.3	1.115	31.3	1.231	879-5	880-5	R-21-5	880-5	880-5	R-21-A-5
	23	0.64	.025	30.5	1.200	28.8	1.133	31.5	1.242	881-5	882-5	R-21-5	882-5	882-5	R-21-A-5
24	0.56	.022	30.6	1.206	28.8	1.133	31.5	1.242	881-5	882-5	R-21-5	882-5	882-5	R-21-A-5	
(34.92) 1.3/8	12	2.76	.109	29.3	1.154	28.8	1.133	31.5	1.242	881-5	882-5	R-21-5	882-5	882-5	R-21-A-5
	14	2.11	.083	30.7	1.209	29.9	1.179	32.9	1.296	885-5	882-5	R-23-5	882-5	882-5	R-23-A-5
	20	0.88	.035	33.2	1.305	31.9	1.257	35.2	1.385	893-5	894-5	R-26-5	894-5	894-5	R-26-A-5
	22	0.71	.028	33.5	1.319	32.6	1.285	36.0	1.417	895-5	896-5	R-26-5	896-5	896-5	R-26-A-5
	24	0.56	.022	33.8	1.331	32.6	1.285	36.0	1.417	895-5	896-5	R-26-5	896-5	896-5	R-26-A-5
(38.10) 1.1/2	17	1.47	.058	35.1	1.384	33.8	1.331	37.8	1.489	899-5	900-5	R-29-5	900-5	900-5	R-29-A-5
	18	1.24	.049	35.6	1.402	33.8	1.331	37.8	1.489	899-5	900-5	R-29-5	900-5	900-5	R-29-A-5
	19	1.06	.042	36.0	1.416	33.8	1.331	37.8	1.489	899-5	900-5	R-29-5	900-5	900-5	R-29-A-5
	20	0.89	.035	36.3	1.430	33.8	1.331	37.8	1.489	899-5	900-5	R-29-5	900-5	900-5	R-29-A-5
	21	0.81	.032	36.5	1.436	33.8	1.331	37.8	1.489	899-5	900-5	R-29-5	900-5	900-5	R-29-A-5
	22	0.71	.028	36.7	1.444	33.8	1.331	37.8	1.489	899-5	900-5	R-29-5	900-5	900-5	R-29-A-5
	23	0.64	.025	36.8	1.450	33.8	1.331	37.8	1.489	899-5	900-5	R-29-5	900-5	900-5	R-29-A-5
	24	0.56	.022	37.0	1.456	33.8	1.331	37.8	1.489	899-5	900-5	R-29-5	900-5	900-5	R-29-A-5

For best results a 'Thin Wall Thrust Collar' should be used when rolling 19 thru 22 gauge wall tubes. (See Pg. 5)  
 Model 815-5 - 858-5 come with 3/8" square mandrel drives and Model 859-5 - 900-5 come with 1/2" square mandrel drives.

# 1200 SERIES LONG REACH

1/2"-1 1/2"  
O.D.

1200 SERIES

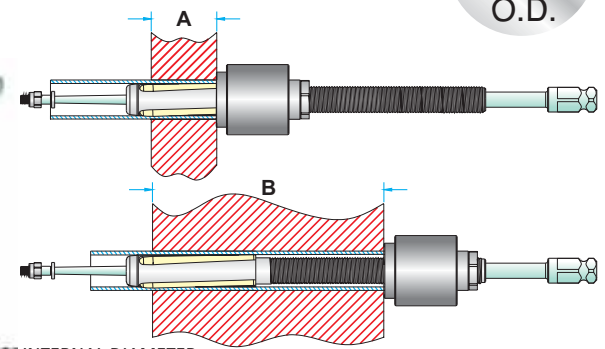

FOR TUBES INTERNAL DIAMETER  
FROM (8.4 mm) .334" TO (36.3 mm) 1.43"

- Use : Most popular tool worldwide for heat exchangers and condensers with tubes of 5/8"-1.1/2" O.D. and thick tube sheets.
- Longer reach expanders are available. Please let us know reach needed.

TUBE EXPANDERS FITTED WITH ROLLER LENGTH		FOR TUBE SHEET ADJUSTABLE RANGE	
		MINIMUM A	MAXIMUM B
(38.1mm) 1.1/2"	STD. REACH	(38.1mm) 1.1/2"	(152.4mm) 6"
	"A" REACH	(38.1mm) 1.1/2"	(203.2mm) 8"
	"B" REACH	(38.1mm) 1.1/2"	(253.8mm) 10"
	"C" REACH	(38.1mm) 1.1/2"	(304.6mm) 12"
(57.1mm) 2.1/4"	STD. REACH	(57.1mm) 2.1/4"	(171.4mm) 6.3/4"
	"A" REACH	(57.1mm) 2.1/4"	(222.1mm) 8.3/4"
	"B" REACH	(57.1mm) 2.1/4"	(272.8mm) 10.3/4"
	"C" REACH	(57.1mm) 2.1/4"	(323.6mm) 12.3/4"

Tube O.D. (mm) inch	Tube Thickness			Tube I.D.		Minimum I.D. Tool Enters		Maximum Expansion of Tool		EXPANDER with (38.10 mm) 1.1/2" Long Rollers			EXPANDER with (57.15 mm) 2.1/4" Long Rollers		
	bwg	mm	inch	mm	inch	mm	inch	mm	inch	Complete Tool No.	Mandrel No.	Rollers Set. No.	Complete Tool No.	Mandrel No.	Rollers Set. No.
(12.70)	14	2.10	.083	8.4	.334	8.2	.324	9.5	.374	1197	1197	797	-	-	-
	15	1.82	.072	9.0	.356	8.8	.348	10.1	.398	1199	1199	R-1	-	-	-
	16	1.65	.065	9.4	.370	9.1	.360	10.4	.410	1201	M-51	R-1	-	-	-
	17	1.47	.058	9.7	.384	9.5	.374	10.7	.424	1203	M-51	R-2	-	-	-
	18	1.24	.049	10.2	.402	9.9	.392	11.3	.447	1205	M-52	R-3	-	-	-
(15.88)	20	0.88	.035	10.9	.430	10.3	.406	11.7	.461	1205 S	M-53	R-3	-	-	-
	12	2.76	.109	10.3	.407	9.9	.392	11.3	.447	1205	M-52	R-3	-	-	-
	13	2.41	.095	11.0	.435	10.8	.425	12.1	.480	1207	M-53	R-4	-	-	-
	14	2.10	.083	11.6	.459	11.4	.449	12.9	.509	1209	M-54	R-4	1210	M-54	R-4-A
	15	1.82	.072	12.2	.481	11.9	.471	13.6	.536	1211	M-55	R-5	1212	M-55	R-5-A
	16	1.65	.065	12.5	.495	12.3	.485	13.9	.550	1213	M-55	R-6	1214	M-55	R-6-A
	17	1.47	.058	12.9	.509	12.6	.499	14.3	.564	1215	M-56	R-6	1216	M-56	R-6-A
	18	1.24	.049	13.3	.527	13.1	.517	14.5	.572	1217	M-57	R-7	1218	M-57	R-7-A
	19	1.06	.042	13.7	.541	13.2	.522	14.7	.582	1219	M-56	R-7	1220	M-56	R-7-A
	20	0.88	.035	14.1	.555	13.6	.536	15.1	.596	1219 S	M-58	R-7	1220 S	M-58	R-7-A
(19.05)	21	0.81	.032	14.2	.561	13.6	.536	15.1	.596	1219 S	M-58	R-7	1220 S	M-58	R-7-A
	22	0.71	.028	14.4	.569	13.6	.536	15.1	.596	1219 S	M-58	R-7	1220 S	M-58	R-7-A
	10	3.40	.134	12.2	.482	11.9	.471	13.6	.536	1211	M-55	R-5	1212	M-55	R-5-A
	11	3.04	.120	12.9	.510	12.6	.499	14.3	.564	1215	M-56	R-6	1216	M-56	R-6-A
	12	2.76	.109	13.5	.532	13.2	.522	14.7	.582	1219	M-56	R-7	1220	M-56	R-7-A
	13	2.41	.095	14.2	.560	13.9	.550	15.6	.615	1221	M-58	R-8	1222	M-58	R-8-A
	14	2.10	.083	14.8	.584	14.5	.574	16.2	.639	1223	M-58	R-9	1224	M-58	R-9-A
	15	1.82	.072	15.3	.606	15.1	.596	16.7	.661	1225	M-58	R-10	1226	M-58	R-10-A
	16	1.65	.065	15.7	.620	15.3	.605	17.4	.685	1227	M-59	R-10	1228	M-59	R-10-A
	17	1.47	.058	16.1	.634	15.7	.619	17.7	.699	1229	M-59	R-11	1230	M-59	R-11-A
(22.22)	18	1.24	.049	16.5	.652	15.7	.619	17.7	.699	1229	M-59	R-11	1230	M-59	R-11-A
	19	1.06	.042	16.9	.666	16.3	.642	18.3	.722	1231	M-59	R-12	1232	M-59	R-12-A
	20	0.88	.035	17.2	.680	16.3	.642	18.3	.722	1231	M-59	R-12	1232	M-59	R-12-A
	21	0.81	.032	17.4	.686	16.3	.642	18.3	.722	1231	M-59	R-12	1232	M-59	R-12-A
	22	0.71	.028	17.6	.694	16.3	.642	18.3	.722	1231	M-59	R-12	1232	M-59	R-12-A
	10	3.40	.134	15.4	.607	15.1	.596	16.7	.661	1225	M-58	R-10	1226	M-58	R-10-A
	11	3.04	.120	16.1	.635	15.7	.619	17.7	.699	1229	M-59	R-11	1230	M-59	R-11-A
	12	2.76	.109	16.6	.657	16.3	.642	18.3	.722	1231	M-59	R-12	1232	M-59	R-12-A
	13	2.41	.095	17.4	.685	17.0	.670	19.0	.750	1233	M-60	R-13	1234	M-60	R-13-A
	14	2.10	.083	18.0	.709	17.4	.685	19.6	.774	1235	M-61	R-14	1236	M-61	R-14-A
15	1.82	.072	18.5	.731	18.0	.712	20.3	.801	1237	M-61	R-15	1238	M-61	R-15-A	
16	1.65	.065	18.9	.745	18.4	.726	20.7	.815	1239	M-62	R-15	1240	M-62	R-15-A	
17	1.47	.058	19.2	.759	18.8	.740	21.0	.829	1243	M-62	R-16	1244	M-62	R-16-A	
18	1.24	.049	19.7	.777	18.8	.740	21.0	.829	1243	M-62	R-16	1244	M-62	R-16-A	

Model 1197-1256 expanders come with 3/8" square mandrel drives and Model 1257-1300 expanders come with 1/2" square mandrel drives.

www.tubeexpanders.com

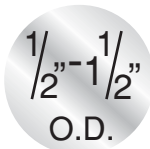

1200 SERIES LONG REACH

Tube O.D. (mm) inch	Tube Thickness			Tube I.D.		Minimum I.D. Tool Enters		Maximum Expansion of Tool		EXPANDER with (38.10 mm) 1.1/2" Long Rollers			EXPANDER with (57.15 mm) 2.1/4" Long Rollers		
	bwg	mm	inch	mm	inch	mm	inch	mm	inch	Complete Tool No.	Mandrel No.	Rollers Set. No.	Complete Tool No.	Mandrel No.	Rollers Set. No.
1 (25.40)	8	4.19	.165	17.0	.670	16.6	.655	18.6	.735	1241	M-59	R-13	1242	M-59	R-13-A
	9	3.75	.148	17.8	.704	17.4	.685	19.6	.774	1235	M-61	R-14	1236	M-61	R-14-A
	10	3.40	.134	18.5	.732	18.0	.712	20.3	.801	1237	M-61	R-15	1238	M-61	R-15-A
	11	3.04	.120	19.3	.760	18.8	.740	21.0	.829	1243	M-62	R-16	1244	M-62	R-16-A
	12	2.76	.109	19.8	.782	19.3	.763	21.6	.852	1245	M-62	R-17	1246	M-62	R-17-A
	13	2.41	.095	20.5	.810	20.0	.791	22.3	.880	1247	M-62	R-18	1248	M-62	R-18-A
	14	2.10	.083	21.1	.834	20.5	.810	23.0	.909	1249	M-63	R-18	1250	M-63	R-18-A
	15	1.82	.072	21.7	.856	21.2	.837	23.7	.936	1251	M-63	R-19	1252	M-63	R-19-A
	16	1.65	.065	22.1	.870	21.2	.837	23.7	.936	1251	M-63	R-19	1252	M-63	R-19-A
	17	1.47	.058	22.4	.884	21.9	.865	24.4	.964	1255	M-63	R-21	1256	M-63	R-21-A
	18	1.24	.049	22.9	.902	21.9	.865	24.4	.964	1255	M-63	R-21	1256	M-63	R-21-A
19	1.06	.042	23.2	.916	21.9	.865	24.4	.964	1255	M-63	R-21	1256	M-63	R-21-A	
20	0.88	.035	23.6	.930	21.9	.865	24.4	.964	1255	M-63	R-21	1256	M-63	R-21-A	
1.1/8 (28.58)	8	4.19	.165	20.1	.795	19.7	.776	22.2	.875	1253	M-63	R-20	1254	M-63	R-20-A
	9	3.75	.148	21.0	.829	20.5	.810	23.0	.909	1249	M-63	R-18	1250	M-63	R-18-A
	10	3.40	.134	21.7	.857	21.2	.837	23.7	.936	1251	M-63	R-19	1252	M-63	R-19-A
	11	3.04	.120	22.4	.885	21.9	.865	24.4	.964	1255	M-63	R-21	1256	M-63	R-21-A
	12	2.76	.109	23.0	.907	22.4	.883	24.9	.982	1257	M-64	R-21	1258	M-64	R-21-A
	13	2.41	.095	23.7	.935	23.2	.916	25.7	1.015	1259	M-64	R-22	1260	M-64	R-22-A
	14	2.10	.083	24.3	.959	23.7	.935	26.5	1.044	1261	M-65	R-23	1262	M-65	R-23-A
	15	1.82	.072	24.9	.981	24.4	.962	27.2	1.071	1263	M-65	R-24	1264	M-65	R-24-A
	16	1.65	.065	25.2	.995	24.4	.962	27.2	1.071	1263	M-65	R-24	1264	M-65	R-24-A
17	1.47	.058	25.6	1.010	25.1	.990	27.9	1.099	1267	M-66	R-26	1268	M-66	R-26-A	
18	1.24	.049	26.0	1.027	25.1	.990	27.9	1.099	1267	M-66	R-26	1268	M-66	R-26-A	
1.1/4 (31.75)	8	4.19	.165	23.3	.920	22.8	.901	25.6	1.010	1265	M-65	R-25	1266	M-65	R-25-A
	9	3.75	.148	24.2	.954	23.7	.935	26.5	1.044	1261	M-65	R-23	1262	M-65	R-23-A
	10	3.40	.134	24.9	.982	24.4	.962	27.2	1.071	1263	M-65	R-24	1264	M-65	R-24-A
	11	3.04	.120	25.6	1.010	25.1	.990	27.9	1.099	1267	M-66	R-26	1268	M-66	R-26-A
	12	2.76	.109	26.2	1.032	25.7	1.013	28.5	1.122	1269	M-66	R-27	1270	M-66	R-27-A
	13	2.41	.095	26.9	1.060	26.4	1.039	29.2	1.150	1271	M-67	R-28	1272	M-67	R-28-A
	14	2.10	.083	27.5	1.084	26.9	1.060	29.6	1.169	1273	M-67	R-29	1274	M-67	R-29-A
	15	1.82	.072	28.0	1.106	27.6	1.087	30.3	1.196	1275	M-67	R-30	1276	M-67	R-30-A
	16	1.65	.065	28.4	1.120	27.6	1.087	30.3	1.196	1275	M-67	R-30	1276	M-67	R-30-A
	17	1.47	.058	28.8	1.134	28.3	1.115	31.0	1.224	1279	M-68	R-30	1280	M-68	R-30-A
18	1.24	.049	29.2	1.152	28.3	1.115	31.0	1.224	1279	M-68	R-30	1280	M-68	R-30-A	
1.3/8 (34.92)	8	4.19	.165	26.5	1.045	26.0	1.026	28.8	1.135	1277	M-67	R-31	1278	M-67	R-31-A
	9	3.75	.148	27.4	1.079	26.9	1.060	29.6	1.169	1273	M-67	R-29	1274	M-67	R-29-A
	10	3.40	.134	28.1	1.107	27.6	1.087	30.3	1.196	1275	M-67	R-30	1276	M-67	R-30-A
	11	3.04	.120	28.8	1.135	28.3	1.115	31.0	1.224	1279	M-68	R-30	1280	M-68	R-30-A
	12	2.76	.109	29.3	1.157	28.7	1.133	31.5	1.242	1281	M-68	R-32	1282	M-68	R-32-A
	13	2.41	.095	30.1	1.185	29.4	1.160	32.3	1.275	1283	M-69	R-33	1284	M-69	R-33-A
	14	2.10	.083	30.7	1.209	29.9	1.179	32.8	1.294	1285	M-70	R-34	1286	M-70	R-34-A
	15	1.82	.072	31.2	1.231	30.6	1.206	33.5	1.321	1287	M-70	R-35	1288	M-70	R-35-A
16	1.65	.065	31.6	1.245	30.6	1.206	33.5	1.321	1287	M-70	R-35	1288	M-70	R-35-A	
1.1/2 (38.10)	8	4.19	.165	29.7	1.170	29.0	1.145	32.0	1.260	1289	M-69	R-34	1290	M-69	R-34-A
	9	3.75	.148	30.5	1.204	29.9	1.177	32.8	1.294	1285	M-70	R-34	1286	M-70	R-34-A
	10	3.40	.134	31.2	1.232	30.6	1.206	33.5	1.321	1287	M-70	R-35	1288	M-70	R-35-A
	11	3.04	.120	32.0	1.260	31.3	1.235	34.2	1.350	1291	M-70	R-36	1292	M-70	R-36-A
	12	2.76	.109	32.5	1.282	31.9	1.257	34.8	1.372	1293	M-70	R-37	1294	M-70	R-37-A
	13	2.41	.095	33.2	1.310	32.6	1.285	35.5	1.400	1295	M-71	R-37	1296	M-71	R-37-A
	14	2.10	.083	33.8	1.334	32.6	1.285	35.5	1.400	1295	M-71	R-37	1296	M-71	R-37-A
	15	1.82	.072	34.4	1.356	33.8	1.331	36.7	1.446	1297	M-71	R-38	1298	M-71	R-38-A
	16	1.65	.065	34.8	1.370	33.8	1.331	36.7	1.446	1297	M-71	R-38	1298	M-71	R-38-A
	17	1.47	.058	35.1	1.384	33.8	1.331	37.3	1.472	1299	M-72	R-38	1300	M-72	R-38-A
	18	1.24	.049	35.6	1.402	33.8	1.331	37.3	1.472	1299	M-72	R-38	1300	M-72	R-38-A
	19	1.06	.042	35.9	1.416	33.8	1.331	37.3	1.472	1299	M-72	R-38	1300	M-72	R-38-A
20	0.88	.035	36.3	1.430	33.8	1.331	37.3	1.472	1299	M-72	R-38	1300	M-72	R-38-A	

Model 1197-1256 expanders come with 3/8" square mandrel drives and Model 1257-1300 expanders come with 1/2" square mandrel drives.



# 1200-5 SERIES FIVE ROLL FOR THIN WALL TUBES

3/4" - 1 1/2"  
O.D.

1200-5 SERIES

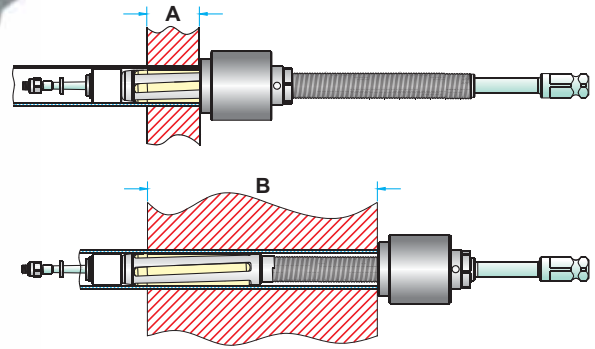

FOR TUBES INTERNAL DIAMETER  
FROM (14.8 mm) .584" TO (36.3 mm) 1.43"

	TUBE EXPANDERS FITTED WITH ROLLER LENGTH	FOR TUBE SHEET ADJUSTABLE RANGE	
		MINIMUM A	MAXIMUM B
(38.1mm) 1.1/2"	STD. REACH	(38.1mm) 1.1/2"	(152.4mm) 6"
	"A" REACH	(38.1mm) 1.1/2"	(203.2mm) 8"
	"B" REACH	(38.1mm) 1.1/2"	(253.8mm) 10"
	"C" REACH	(38.1mm) 1.1/2"	(304.6mm) 12"
(57.1mm) 2.1/4"	STD. REACH	(57.1mm) 2.1/4"	(171.4mm) 6.3/4"
	"A" REACH	(57.1mm) 2.1/4"	(222.1mm) 8.3/4"
	"B" REACH	(57.1mm) 2.1/4"	(272.8mm) 10.3/4"
	"C" REACH	(57.1mm) 2.1/4"	(323.6mm) 12.3/4"

- Use : Highly recommended for use on thin walled tubes (19 thru 22 gage walls) of Stainless Steel, Titanium, Incoloy and other exotic materials in thick tube sheets.
- Advantages : Gives a more concentric and even expansion when expanding thin walled tubes vs. a conventional 3 roll expander and reduces tube spring back effect.
- Expanders for tube sizes not listed below are also available. Please enquire.

Tube O.D. (mm) inch	Tube Thickness			Tube I.D.		Minimum I.D. Tool Enters		Maximum Expansion of Tool		EXPANDER with (38.10 mm) 1.1/2" Long Rollers			EXPANDER with (57.15) 2.1/4" Long Rollers		
	bwg	mm	inch	mm	inch	mm	inch	mm	inch	Complete Tool No.	Mandrel No.	Rollers Set. No.	Complete Tool No.	Mandrel No.	Rollers Set. No.
(19.05) 3/4	14	2.10	.083	14.8	.584	14.5	.574	16.2	.639	1223-5	1224-5	R-6-5	1224-5	1224-5	R-6-A-5
	15	1.82	.072	15.3	.606	14.9	.590	16.7	.661	1225-5	1226-5	R-7-5	1226-5	1226-5	R-7-A-5
	16	1.65	.065	15.7	.620	15.3	.605	17.4	.685	1227-5	M-63	R-7-5	1228-5	M-63	R-7-A-5
	17	1.47	.058	16.1	.634	15.7	.619	17.8	.699	1229-5	1230-5	R-7-5	1230-5	1230-5	R-7-A-5
	18	1.24	.049	16.5	.652	15.7	.619	17.8	.699	1229-5	1230-5	R-7-5	1230-5	1230-5	R-7-A-5
	19	1.06	.042	16.9	.666	16.3	.642	18.5	.722	1231-5	M-63	R-9-5	1232-5	M-63	R-9-A-5
	20	0.88	.035	17.2	.680	16.3	.642	18.5	.722	1231-5	M-63	R-9-5	1232-5	M-63	R-9-A-5
	21	0.81	.032	17.4	.686	16.3	.642	18.5	.722	1231-5	M-63	R-9-5	1232-5	M-63	R-9-A-5
(25.40) 1	22	0.71	.028	17.6	.694	16.3	.642	18.5	.722	1231-5	M-63	R-9-5	1232-5	M-63	R-9-A-5
	14	2.10	.083	21.1	.834	20.5	.810	23.0	.909	1249-5	1250-5	R-12-5	1250-5	1250-5	R-12-A-5
	15	1.82	.072	21.7	.856	21.2	.837	23.7	.936	1251-5	1251-5	R-13-5	1252-5	1251-5	R-13-A-5
	16	1.65	.065	22.0	.870	21.2	.837	23.7	.936	1251-5	1251-5	R-13-5	1252-5	1251-5	R-13-A-5
	17	1.47	.058	22.4	.884	21.9	.865	24.4	.964	1255-5	1256-5	R-13-5	1256-5	1256-5	R-13-A-5
	18	1.24	.049	22.9	.902	21.9	.865	24.4	.964	1255-5	1256-5	R-13-5	1256-5	1256-5	R-13-A-5
	19	1.06	.042	23.2	.916	21.9	.865	24.4	.964	1255-5	1256-5	R-13-5	1256-5	1256-5	R-13-A-5
	20	0.88	.035	23.6	.930	21.9	.865	24.4	.964	1255-5	1256-5	R-13-5	1256-5	1256-5	R-13-A-5
(28.58) 1.1/8	21	0.81	.032	23.8	.936	22.4	.883	24.9	.982	1257-5	M-71-3/8	R-15-5	1258-5	M-71-3/8	R-15-A-5
	22	0.71	.028	24.0	.944	22.4	.883	24.9	.982	1257-5	M-71-3/8	R-15-5	1258-5	M-71-3/8	R-15-A-5
	12	2.76	.109	23.0	.907	22.4	.883	24.9	.982	1257-5	M-71-3/8	R-15-5	1258-5	M-71-3/8	R-15-A-5
(38.10) 1.1/2	15	1.82	.072	24.9	.981	24.4	.962	27.2	1.071	1263-5	1263-5	R-18-5	-	-	-
	16	1.65	.065	25.2	.995	24.4	.962	27.2	1.071	1263-5	1263-5	R-18-5	-	-	-
	17	1.47	.058	35.1	1.384	33.8	1.331	37.3	1.472	1299-5	1299-5	R-29-5	1300-5	1299-5	R-29-A-5
(38.10) 1.1/2	18	1.24	.049	35.6	1.402	33.8	1.331	37.3	1.472	1299-5	1299-5	R-29-5	1300-5	1299-5	R-29-A-5
	19	1.06	.042	36.0	1.416	33.8	1.331	37.3	1.472	1299-5	1299-5	R-29-5	1300-5	1299-5	R-29-A-5
	20	0.89	.035	36.3	1.430	33.8	1.331	37.3	1.472	1299-5	1299-5	R-29-5	1300-5	1299-5	R-29-A-5

For best results a 'Thin Wall Thrust Collar' should be used when rolling 19 thru 22 gauge wall tubes. (See Pg. 5)

Model 1223-5 - 1258-5 expanders come with 3/8" square mandrel drives and Model 1263-5 - 1300-5 expanders come with 1/2" square mandrel drives.

www.tubeexpanders.com

1 3/4" - 5"  
O.D.

8012 SERIES

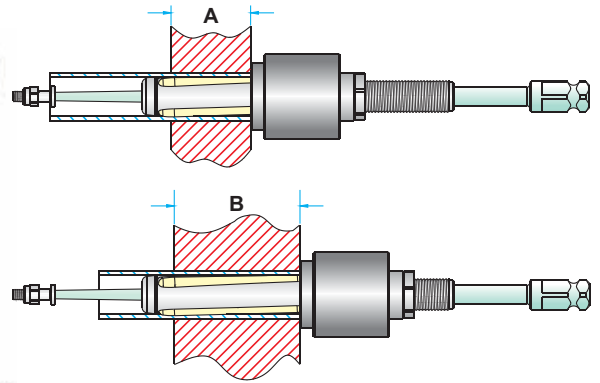

FOR TUBES INTERNAL DIAMETER  
FROM (36.1 mm) 1.420" TO (123.7 mm) 4.870"

TUBE EXPANDERS FITTED WITH ROLLER LENGTH	FOR TUBE SHEET ADJUSTABLE RANGE	
	MINIMUM A	MAXIMUM B
2.1/4" (57.1mm)	STD. REACH	(12.7mm) 1/2" (101.4mm) 4"
	- 6" REACH	(12.7mm) 1/2" (152.4mm) 6"
	- 8" REACH	(12.7mm) 1/2" (203.2mm) 8"

For Mandrels in 6" and 8" reach - suffix -6" or -8" to the mandrel model number.

- Use : To expand tubes in Air Heaters, Boilers and Refinery still tubes. Can be used to expand thick tube sheets (upto 8").
- For Larger Size '8012' series expanders, please contact us.

Tube O.D. (mm) inch	Tube Thickness			Tube I.D.		Minimum I.D. Tool Enters		Maximum Expansion of Tool		EXPANDER with (57.15 mm) 2.1/4" Long Rollers			
	bwg	mm	inch	mm	inch	mm	inch	mm	inch	Complete Tool No.	Mandrel No.	Rollers Set. No.	
(44.45)	1.3/4	8	4.19	.165	36.1	1.420	34.7	1.368	39.3	1.550	8012-1.3/4-8	M-90	R-33-A
		10	3.40	.134	37.6	1.482	36.0	1.420	40.8	1.607	8012-1.3/4-10	M-90	R-37-A
		11	3.04	.120	38.3	1.510	36.9	1.454	41.5	1.635	8012-1.3/4-11	M-90	R-42
		12	2.76	.109	38.9	1.532	37.6	1.482	42.0	1.657	8012-1.3/4-12	M-90	R-44
		13	2.41	.095	39.6	1.560	38.3	1.510	42.7	1.685	8012-1.3/4-13	M-90	R-46
		14	2.10	.083	40.2	1.584	38.9	1.532	43.4	1.709	8012-1.3/4-14	M-90	R-48
(50.80)	2	7	4.57	.180	41.6	1.640	39.8	1.570	45.0	1.770	8012-2-7	M-91	R-46
		8	4.19	.165	42.4	1.670	40.5	1.595	45.6	1.795	8012-2-8	M-91	R-48
		10	3.40	.134	43.9	1.732	41.6	1.640	47.1	1.857	8012-2-10	M-91	R-50
		11	3.04	.120	44.7	1.760	42.4	1.670	47.8	1.885	8012-2-11	M-91	R-52
		12	2.76	.109	45.2	1.782	43.2	1.704	48.4	1.907	8012-2-12	M-91	R-54
		13	2.41	.095	45.9	1.810	43.9	1.732	49.6	1.956	8012-2-13-18	M-91	R-56
		14	2.10	.083	46.5	1.834	43.9	1.732	49.6	1.956	8012-2-13-18	M-91	R-56
		15	1.83	.072	47.1	1.856	43.9	1.732	49.6	1.956	8012-2-13-18	M-91	R-56
		16	1.65	.065	47.4	1.870	43.9	1.732	49.6	1.956	8012-2-13-18	M-91	R-56
		17	1.47	.058	47.9	1.884	43.9	1.732	49.6	1.956	8012-2-13-18	M-91	R-56
18	1.24	.049	48.3	1.902	43.9	1.732	49.6	1.956	8012-2-13-18	M-91	R-56		
(57.15)	2.1/4	10	3.40	.134	50.3	1.982	48.0	1.890	53.5	2.107	8012-2.1/4-10	M-92	R-56
		11	3.04	.120	51.0	2.010	48.7	1.920	54.2	2.135	8012-2.1/4-11	M-92	R-58
		12	2.76	.109	51.6	2.032	49.6	1.954	54.7	2.157	8012-2.1/4-12	M-92	R-60
		13	2.41	.095	52.3	2.060	50.3	1.982	55.4	2.185	8012-2.1/4-13-16	M-92	R-62
		14	2.10	.083	52.9	2.084	50.3	1.982	55.4	2.185	8012-2.1/4-13-16	M-92	R-62
		15	1.83	.072	53.4	2.106	50.3	1.982	55.4	2.185	8012-2.1/4-13-16	M-92	R-62
(63.50)	2.1/2	7-8	4.50	.177	54.5	2.146	52.0	2.050	59.3	2.335	8012-2.1/2-7-8	M-92	R-45-A
		9	3.75	.148	56.0	2.204	53.5	2.106	60.4	2.380	8012-2.1/2-9	M-93	R-46-A
		10	3.40	.134	56.6	2.232	54.3	2.140	61.1	2.407	8012-2.1/2-10-12	M-93	R-64
		11	3.04	.120	57.4	2.260	54.3	2.140	61.1	2.407	8012-2.1/2-10-12	M-93	R-64
		12	2.76	.109	57.9	2.282	54.3	2.140	61.1	2.407	8012-2.1/2-10-12	M-93	R-64
		13	2.41	.095	58.6	2.310	56.6	2.232	62.2	2.450	8012-2.1/2-13-18	M-94	R-64
		14	2.10	.083	59.2	2.334	56.6	2.232	62.2	2.450	8012-2.1/2-13-18	M-94	R-64
		15	1.83	.072	59.8	2.356	56.6	2.232	62.2	2.450	8012-2.1/2-13-18	M-94	R-64
		16	1.65	.065	60.1	2.370	56.6	2.232	62.2	2.450	8012-2.1/2-13-18	M-94	R-64
		17	1.47	.058	60.6	2.384	56.6	2.232	62.2	2.450	8012-2.1/2-13-18	M-94	R-64
18	1.24	.049	61.0	2.402	56.6	2.232	62.2	2.450	8012-2.1/2-13-18	M-94	R-64		

Model 8012-1.3/4-8 - 8012-2.1/2-13-18 expanders come with 3/4" square mandrel drives. Model 8012-2.3/4-10-16 - 8012-5-10-18 expanders come with 1" square mandrel drives.

# 8012 SERIES

1 3/4" - 5"  
O.D.

Tube O.D. (mm) inch	Tube Thickness			Tube I.D.		Minimum I.D. Tool Enters		Maximum Expansion of Tool		EXPANDER with (57.15 mm) 2.1/4" Long Rollers		
	bwg	mm	inch	mm	inch	mm	inch	mm	inch	Complete Tool No.	Mandrel No.	Rollers Set. No.
(69.85) 2.3/4	10	3.40	.134	63.0	2.482	60.7	2.390	68.6	2.702	8012-2.3/4-10-16	M-96	R-66
	11	3.04	.120	63.7	2.510	60.7	2.390	68.6	2.702	8012-2.3/4-10-16	M-96	R-66
	12	2.76	.109	64.3	2.532	60.7	2.390	68.6	2.702	8012-2.3/4-10-16	M-96	R-66
	13	2.41	.095	65.0	2.560	60.7	2.390	68.6	2.702	8012-2.3/4-10-16	M-96	R-66
	14	2.10	.083	65.6	2.584	60.7	2.390	68.6	2.702	8012-2.3/4-10-16	M-96	R-66
	15	1.83	.072	66.1	2.606	60.7	2.390	68.6	2.702	8012-2.3/4-10-16	M-96	R-66
	16	1.65	.065	66.5	2.620	60.7	2.390	68.6	2.702	8012-2.3/4-10-16	M-96	R-66
(76.20) 3	8	4.19	.165	67.8	2.670	65.0	2.560	71.8	2.829	8012-3-8-9	M-97	R-67
	9	3.75	.148	68.6	2.704	65.0	2.560	71.8	2.829	8012-3-8-9	M-97	R-67
	10	3.40	.134	69.3	2.732	67.0	2.640	74.9	2.952	8012-3-10-18	M-96	R-67
	11	3.04	.120	70.1	2.760	67.0	2.640	74.9	2.952	8012-3-10-18	M-96	R-67
	12	2.76	.109	70.6	2.782	67.0	2.640	74.9	2.952	8012-3-10-18	M-96	R-67
	13	2.41	.095	71.3	2.810	67.0	2.640	74.9	2.952	8012-3-10-18	M-96	R-67
	14	2.10	.083	71.9	2.834	67.0	2.640	74.9	2.952	8012-3-10-18	M-96	R-67
	15	1.82	.072	72.5	2.856	67.0	2.640	74.9	2.952	8012-3-10-18	M-96	R-67
	16	1.65	.065	72.8	2.870	67.0	2.640	74.9	2.952	8012-3-10-18	M-96	R-67
(88.9) 3.1/2	13	2.41	.095	84.1	3.311	81.0	3.190	88.0	3.464	8012-3.1/2-10-18	M-99	R-70
	14	2.10	.083	84.7	3.334	81.0	3.190	88.0	3.464	8012-3.1/2-10-18	M-99	R-70
	15	1.83	.072	85.2	3.354	81.0	3.190	88.0	3.464	8012-3.1/2-10-18	M-99	R-70
	16	1.65	.065	85.6	3.370	81.0	3.190	88.0	3.464	8012-3.1/2-10-18	M-99	R-70
	17	1.47	.058	86.0	3.385	81.0	3.190	88.0	3.464	8012-3.1/2-10-18	M-99	R-70
	18	1.24	.049	86.4	3.401	81.0	3.190	88.0	3.464	8012-3.1/2-10-18	M-99	R-70
(101.6) 4	3	6.60	.259	88.4	3.480	87.0	3.425	96.0	3.780	8012-4-3-4	M-100	R-71
	4	6.00	.236	89.6	3.527	87.0	3.425	96.0	3.780	8012-4-3-4	M-100	R-71
	8	4.19	.165	93.2	3.670	91.0	3.582	100.0	3.940	8012-4-8-9	M-101	R-71
	9	3.75	.148	94.1	3.704	91.0	3.582	100.0	3.940	8012-4-8-9	M-101	R-71
	10	3.40	.134	94.8	3.732	93.0	3.661	100.6	3.960	8012-4-10-18	M-101	R-72
	11	3.04	.120	95.5	3.760	93.0	3.661	100.6	3.960	8012-4-10-18	M-101	R-72
	12	2.76	.109	96.1	3.783	93.0	3.661	100.6	3.960	8012-4-10-18	M-101	R-72
	13	2.41	.095	96.8	3.811	93.0	3.661	100.6	3.960	8012-4-10-18	M-101	R-72
	14	2.10	.083	97.4	3.834	93.0	3.661	100.6	3.960	8012-4-10-18	M-101	R-72
(114.3) 4.1/2	3	6.60	.259	101.1	3.980	100.0	3.940	109.0	4.291	8012-4.1/2-3-4	M-102	R-73
	4	6.00	.236	102.3	4.030	100.0	3.940	109.0	4.291	8012-4.1/2-3-4	M-102	R-73
	8	4.19	.165	105.9	4.170	102.0	4.020	111.0	4.370	8012-4.1/2-8-9	M-102	R-74
	9	3.75	.148	106.8	4.204	102.0	4.020	111.0	4.370	8012-4.1/2-8-9	M-102	R-74
	10	3.40	.134	107.5	4.232	104.0	4.100	113.0	4.450	8012-4.1/2-10-18	M-103	R-74
	12	2.76	.109	108.8	4.283	104.0	4.100	113.0	4.450	8012-4.1/2-10-18	M-103	R-74
	16	1.65	.065	111.0	4.370	104.0	4.100	113.0	4.450	8012-4.1/2-10-18	M-103	R-74
(127.0) 5	3	6.60	.259	113.8	4.480	112.0	4.410	121.0	4.763	8012-5-3-4	M-105	R-76
	4	6.00	.236	115.0	4.527	112.0	4.410	121.0	4.763	8012-5-3-4	M-105	R-76
	8	4.19	.165	118.6	4.670	116.0	4.566	125.0	4.921	8012-5-8-9	M-105	R-77
	9	3.75	.148	119.5	4.704	116.0	4.566	125.0	4.921	8012-5-8-9	M-105	R-77
	10	3.40	.134	120.2	4.732	117.0	4.606	126.0	4.960	8012-5-10-18	M-105	R-78
	11	3.04	.120	121.0	4.763	117.0	4.606	126.0	4.960	8012-5-10-18	M-105	R-78
	12	2.76	.109	121.5	4.783	117.0	4.606	126.0	4.960	8012-5-10-18	M-105	R-78
	14	2.10	.083	122.8	4.834	117.0	4.606	126.0	4.960	8012-5-10-18	M-105	R-78
16	1.65	.065	123.7	4.870	117.0	4.606	126.0	4.960	8012-5-10-18	M-105	R-78	

Model 8012-1.3/4-8 - 8012-2.1/2-13-18 expanders come with 3/4" square mandrel drives. Model 8012-2.3/4-10-16 - 8012-5-10-18 expanders come with 1" square mandrel drives.

## SPECIAL TUBE EXPANDERS

### STEP ROLLING EXPANDER (BAFFLE PLATE EXPANDERS)



Ideally suited for faster tube rolling in tube sheets that are 10" (250 mm) and thicker without removing the tube expander from the tube. Tube expander cage has grooves spaced 1" apart and is fitted with a spring loaded, quick spacing thrust collar that permits fast step rolling in 1" increments throughout the full thickness of the tube sheet. These expanders can be made for use in upto 236" (6000 mm) reaches.

#### DIESEL ENGINE EXPANDER



A special series of tube expanders designed for rolling the injection sleeves into the head of diesel engines. These tube expanders are made to order for each application, and a detailed drawing of the injector sleeve and the engine head must accompany the order to ensure proper tube expander design.

#### SR EXPANDER



The rapid taper on the mandrel of this tube expander allows full expansion of the tube with minimum travel of the mandrel. The mandrel is retained at the rear of the tube expander to shorten the length of the tube expander and to allow the tube expander to be used near sharp tube bends.

## HYDRAULIC THRUST TUBE EXPANDERS

**FOR USE WITH VMH HYDRAULIC EXPANSION SYSTEM FOR HEAT EXCHANGERS.**



#### *Features :*

- This system uses high speed steel tube expanders to expand very thick wall and exotic harder tubes, where conventional expanders would fail.
- Axis of the roll slot in tool is parallel to the cage axis.
- Internal cylindricality of the expanded tube.
- Reduction of tube stretching.
- Better quality of tube to tube sheet contact.
- Reduction in tube internal stress.
- Hydraulic Thrust tube expanders are interchangeable and can be used with 'Vernon' hydraulic tube expanding systems.

#### TOOLS FOR USE WITH VMH HYDRAULIC EXPANSION SYSTEM.



**'S' Series**

For Tube Sizes	1/2" - 2" O.D.
Roller Length	1.1/2" - 2.1/2"
For Tube Sheets	1.1/4" - 5.1/2"



**'A' Series**

For Tube Sizes	1/2" - 1.1/4" O.D.
Roller Length	2.5/16" - 3.1/2"
For Tube Sheets	2.3/16" - 3.3/8"

**Note :** Please ask for catalog number HTTE/038/1 for detailed selection of Hydraulic Thrust tube expanders.

## LUBE-A-TUBE

For expander rolling tube ends into tube sheets.

**Application :** Apply directly to the inside of the tube ends by hand.

**Removal :** Any excess of Lube-A-Tube is removed by wiping or the residue will be completely removed during hydrotest / boil-out operations.

#### *Features :*

- Being a soft, paste lubricant, Tube-A-Tube is easy to apply and "stays put" in the tube prior to the actual rolling operation - it will not run like oil.
- No chance of entering between the tube sheet and tube end OD.
- Will not carbonize under the heat and pressure encountered during the tube rolling operation.
- Lube-A-Tube is its own indicator serving to show the operator what tubes are still to be expanded, eliminating the possibility of missed tubes.
- Lube-A-Tube keeps the expanding tool cool and prolongs tool life.
- Equally effective for rolling condenser tubes, boiler tubes and heavy wall cracking still tubes in refining equipment.



Sold in 100 ml tubes or 2 kg cans.



# TUBE ROLLING CONTROLS

Page 19-30



# ELECTRIC TUBE EXPANSION SYSTEMS

## “WATTAGE” BASED TORQUE CONTROLLERS

### Why a “Wattage” Based Torque Controller is Right and a “Current” Based Torque Controller is Wrong.

A) Tube expansion can best be done by expanding tubes at a set torque value. Torque is nothing but a rotary force acting on the tubes. For a given drive, the 'RPM' being constant, torque becomes proportional to the drive power.

Hence, if the drive power is controlled for tube expansion, the results will be excellent. All tubes will be expanded equally. Supply voltage fluctuations which are very common, do not affect the performance of a wattage based controller as the controller will trip at a set wattage irrespective of the supply voltage.

B) In case of a current based tube expansion torque controller, the drive current can become proportional to the torque if & only if the supply voltage is absolutely constant. This is never the case. Practically, the supply voltages vary as much as 20% to 25%. This directly affects the expansion results as the drive trips at a set current. That means for a 20% higher supply voltage, the tubes will be effectively expanded by 20% more torque than the required one. Hence tubes will be over-expanded. For supply voltages less than normal, tubes will be under expanded proportionately.

Since, the supply voltages fluctuate quite often, the expansion results of current based controllers will be unpredictable. They will have no consistency.

It is our experience that a seasoned operator will more consistently expand tubes with just a drive than if he is to use a current based Torque Controller. Of course if he were to use a Wattage based torque controller, he would achieve near perfect tube expansions all the time.

**POWERMASTER is the only company in the world to offer you a choice of 2 Wattage based Torque Controllers.**



**PR-2000 - BUILT IN PRINTER**



**PR-2000 - EXTERNAL PRINTER**

1. **PR-2000 Series**, with microprocessor control, built in printer and computer connectivity to download and study expansion values. Ability to generate 10 report formats for quality control of expanded joints. Operates with a remote control.



2. **TCW Series**, which is a less expensive alternate to the above but has features like a 'slow start' for the drives, automatic recognition of connected drives and automatic setting of max trip values for each drive.

# PR-2000 TORQUE CONTROLLER



## Features :

- 1) Microcontroller base, PC compatible Electronic Torque Controller uses the latest "State of the art" technology.
- 2) Setting of torque on a digital display in pure numbers.
- 3) Fully automatic operation.
- 4) Adjustable reverse and pause times.
- 5) Smooth start enables connection of any make of drive to the controller, improves brush life and enables re-expansion of tubes.
- 6) The auto-repeat feature with programmed acceleration allows you to estimate the exact expansion time.
- 7) Manual reverse operation provided.
- 8) Easy to set up and use, no special skill required .
- 9) Number keys are provided - enable direct entry of required parameter value.  
The Torque Controller data can be transferred to PC through a separate connector which has been provided on the remote handset.  
The data of torque values of expansions can be stored on a disc through the PC. This data can be further processed and analysed for quality checks through the PC.
- 10) Plugin type PCB's - Easy for servicing.
- 11) Rugged and reliable design.
- 12) Built -in printer or external printer-both options available. Print out possible of trip setting plus minimum, maximum and average of trips. Upto 950 expansions can be stored in memory.
- 13) Statistical print outs of under/over expanded tubes with specific tube numbers makes quality control of expanded tubes easier and faster.
- 14) Initial slow speed up of drive programmed in the controller, increases life of drives.
- 15) Key pad provided on a remote hand set gives following advantages.
  - A) Change of set values by authorised person only.
  - B) Set values are tamper proof.
  - C) Data stored in controller memory can be loaded to PC for further processing via the hand set. Controller need not be taken to the PC.
- 16) Line Voltage can be easily seen on controller display.
- 17) On connecting a drive, controller automatically sets the maximum trip wattage and indicates drive model.
- 18) Drive's reverse speed can be fixed at slow or fast.
- 19) 16 character 2 line alpha numeric LCD display guides the operator.
- 20) Display of adjusted reverse and pause times. Real time clock enables automatic printing of date & time of starting of job.

Microprocessor used	:	89C55WD (8 bit)
Clock Frequency	:	12 Mhz
Programme Memory	:	built in
Data Storage Memory (E2PROM)	:	1 K
Real Power Measurement upto	:	2 KW
Voltage, Current sampling rate	:	50 times/sec.
No. of values that can be stored	:	950
Printer	:	Inbuilt / External

Model No.	Voltage Single Phase 50/60 Hz	Weight (kg)	
		With Printer	Without Printer
PR-2000-110	110 V	19.0	9.0
PR-2000-230	230 V	19.0	9.0

**Note :** Refer to Pg. 23 & 24 for Drive Units, Voltage Stabilizers for use with PR-2000 torque controllers.  
All PR-2000 torque controllers are supplied with operation manuals.

# TCW TORQUE CONTROLLER

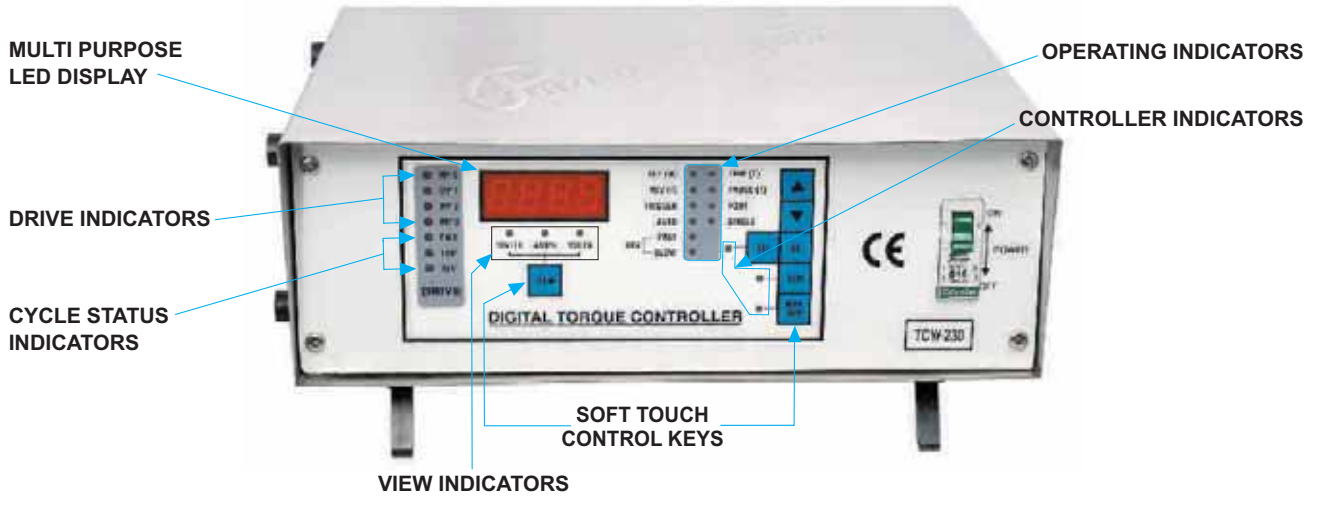

### Features :

- 1) Fully Solid State Design - no moving parts - no wear and tear of parts - no noise - consequently long life.
- 2) Uses one main circuit board for easy maintenance.
- 3) Uses the latest micro-controller chip for control functions.
- 4) Accurately calibrated digital torque settings with a resolution of 1 watt makes torque settings accurate and can be easily reproduced for identical results.
- 5) Soft start has been provided for all drives. This feature reduces starting currents in the drive. As a result, life of carbon brushes & drive increases.
- 6) Connected drive is automatically recognised & indicated by means of LED on the torque controller.
- 7) Torque setting arranged in four different ranges to suit four different drives. Appropriate wattage range is automatically selected for the connected drive, hence drives can not be abused or overused.
- 8) Actual drive wattage (torque) is displayed. Set wattage (torque), drive current and line voltage can be seen by press of a button.
- 9) Trip time adjustable from ( 0.1 sec to 10 secs. )
- 10) Adjustable reverse time from ( 1 sec to 100 secs.)
- 11) Pause time (time interval between cycles) adjustable from ( 1 sec to 100 secs.)
- 12) Manual reverse by push button, in case of emergency.
- 13) Drive Speed adjustable in reverse rotation.
- 14) Hand (trigger) mode or foot switch mode, both are available.
- 15) Expansions can be carried out either in single cycle mode or auto repeat mode.
- 16) LED indicators provided for forward, reverse & trip conditions of drive.
- 17) MCB has been provided to protect the controller and drives against over current by short circuits.
- 18) Plug in type of PCBs reduce down time to minimum during trouble shooting.
- 19) All the spares inside the panel viz : PCBs, Transformers, CT, Relays DPM etc. can be replaced by use of only a screw driver.
- 20) Superior SCR technology has been incorporated rather than triacs. SCRS have much better voltage, current & dv/dt ratings than triacs. This leads to greater reliability & the power circuit becomes almost failsafe.
- 21) Powermaster has over 1000 TCW Torque Controllers in active use worldwide since its inception in year 2000.

Microprocessor used : 89C55WD (8 bit)  
 Clock Frequency : 12 Mhz  
 Programme Memory : built in  
 Real Power Measurement upto : 2 KW  
 Voltage, Current sampling rate : 50 times/sec.

Model No.	Voltage Single Phase 50/60 Hz	Weight (kg)
TCW-110	110 V	7.5
TCW-230	230 V	7.5

**Note :** Refer to Pg. 23 & 24 for Drive Units, Voltage Stabilizers for use with TCW torque controllers.  
 All TCW torque controllers are supplied with operation manuals.



# ELECTRIC DRIVES FOR USE WITH TORQUE CONTROLLERS



MPB - 0



MPB - 1



MPG - 2



MPG - 3



## Features :

- 1) Heavy Duty German motors form the heart of these drives.
- 2) Continuous cycle operation vs. Intermittent cycle operation of drives from other manufactures.
- 3) High torque to weight ratio.

## SPECIFICATIONS

Supply Voltage Single Phase 50/60 Hz	Drive Model	Speed I / II	No Load R.P.M.	Expansion Range				Drive Weight Kgs.
				Steel Tube O.D.		Copper Tube O.D.		
				inch	mm	inch	mm	
230 V	MPB - 0N	I	2200	1/4" - 3/8"	6 - 10	1/4" - 1/2"	6 - 12	2
		II	1000	3/8" - 5/8"	10 - 16	3/8" - 3/4"	13 - 20	
	MPB - 1N	I	1900	5/16" - 3/8"	8 - 13	5/16" - 1/2"	8 - 13	2.5
		II	480	5/8" - 1.3/4"	16 - 45	5/8" - 2"	16 - 50	
	MPG - 2N	I	1080	5/8" - 1.1/4"	16 - 32	5/8" - 1.1/2"	16 - 38	7.5
		II	130	1" - 3"	25 - 76	1" - 4"	25 - 102	
MPG - 3N	I	430	1" - 2"	25 - 50	1" - 3"	25 - 76	8.5	
	II	430	1" - 2"	25 - 50	1" - 3"	25 - 76		
110 V	MPB - 0L	I	2200	1/4" - 3/8"	6 - 10	1/4" - 1/2"	6 - 12	2
		II	1000	3/8" - 5/8"	10 - 16	3/8" - 3/4"	13 - 20	
	MPB - 1L	I	1900	5/16" - 3/8"	8 - 13	5/16" - 1/2"	8 - 13	2.5
		II	480	5/8" - 1.3/4"	16 - 45	5/8" - 2"	16 - 50	
	MPG - 2L	I	1080	5/8" - 1.1/4"	16 - 32	5/8" - 1.1/2"	16 - 38	7.5
		II	130	1" - 3"	25 - 76	1" - 4"	25 - 102	
MPG - 3L	I	430	1" - 2"	25 - 50	1" - 3"	25 - 76	8.5	
	II	430	1" - 2"	25 - 50	1" - 3"	25 - 76		

# VOLTAGE STABILIZERS / TRANSFORMERS

FOR USE WITH TORQUE CONTROLLERS



- Features :*
- Digital display of output voltage.
  - Used in on site application and areas which are prone to high voltage fluctuations.

Model No.	Input Voltage (V)	Output Voltage (V)
VS1BB	160 - 260	103 - 118
VS2BB	160 - 260	215 - 245

# ACCESSORIES FOR ELECTRIC TUBE EXPANSION SYSTEM



**TROLLEY**

- Features :*
- Heavy Duty Sheet Metal Construction.
  - Conveniently houses all tools needed for expanding tubes.

Model	Description
FS-1	Set of 3 Foot Switches
TCW	Torque Controller
TR-1	Collapsible Trolley - Stainless Steel
SWF-5	Spring Balancer
SB-1	Swivel Bracket
MP	Electric Drive
TS	Telescopic Shaft

# TELESCOPIC SHAFTS

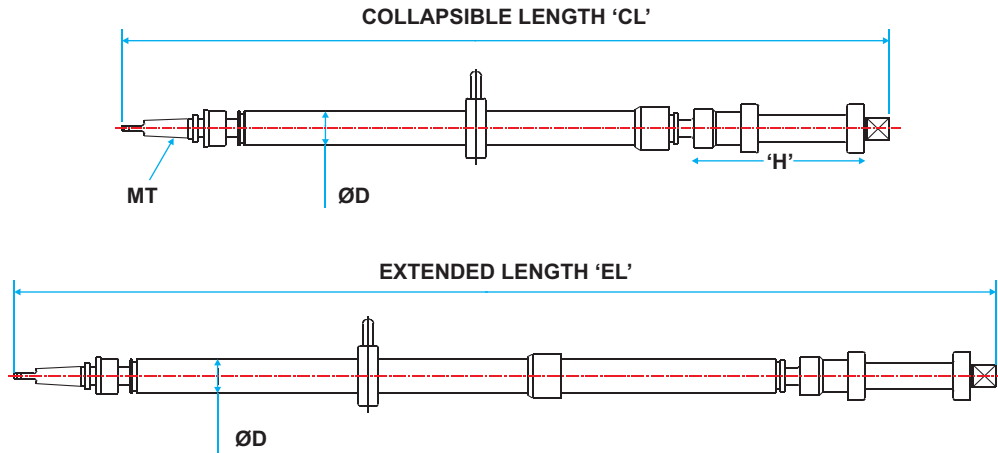

## Features :

- Used to free the operator from handling drives.
- Sturdy construction absorbs all torque during tube expansion.

Model Number	MT Shank	CL mm	EL mm	Handle Length 'H' mm	D mm	For Use with Drive Model	Weight kg	Supplied with Quick Change Chucks and Adaptors of Following Sizes
TS-1 E	2 MT	850	1250	200	38.0	MP-2	2.75	3/8", 1/2", 3/4"
TS-2 E	3 MT	1000	1505	225	38.0	MP-3	5.75	1/2", 3/4", 1"
TS-3 E	3 MT	1000	1400	250	51.0	MP-3	9.20	1/2", 3/4", 1"

# QUICK CHANGE CHUCKS AND ADAPTORS

## Features :

- For use directly with Rolling Motors - electric, hydraulic and pneumatic.
- For use with Telescopic Shafts.
- Any combination possible for use with any manufacturers equipment.
- Specify square size and thread type (if applicable) on either end of quick change chuck / adaptor when ordering.

### QUICK CHANGE CHUCK



Specify Square Size  
(to couple to expander mandrel square)

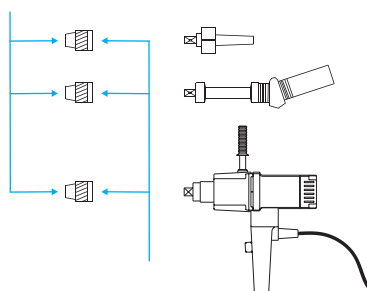

Specify Square or thread size  
(to couple to rolling motor / telescopic shaft)

### ADAPTOR



Specify Square Size  
(to couple to expander mandrel square)

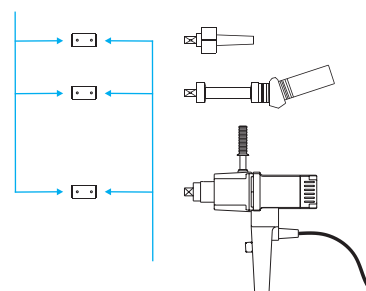

Specify Square or thread size  
(to couple to rolling motor / telescopic shaft)

# HYDRAULIC THRUST EXPANSION SYSTEM

## USING IN LINE ROLL TUBE EXPANDERS

### Features :

- Specially designed to expand stainless steel thick walled and exotic harder tubes, where conventional expanders would fail.
- Can expand tubes in a deep channel using stepping extension.
- Quality leak proof joint in 3 to 5 seconds.
- Precise control of advancing force.
- Constant RPM even under load condition ensures equal pressure to the rolls for tight fit, leak proof joint between tube and tube sheet.
- Internal cylindricity of expanded tubes.
- Durable heavy-duty construction ensures long reliable life.
- Reduction of tube stretching & internal stresses.
- Simple operation saves time & reduces operator fatigue.
- Large oil tank and external filter for better cooling effect and easy filter replacement.
- Automatic lubrication system increases tool life and reduces consumable cost.
- Continuous programmed cycle-microprocessor controlled.



### PUMP SPECIFICATION

- Power Requirement : 415v, 3 Phase
- Electric motor : 5 HP
- Reservoir Capacity : 138 liters (32 gallons)
- Weight : 450 kg (990 lbs)
- Height : 1000 mm (39") over reservoir  
2630 mm (103") over suspension system
- Base : 1220 mm x 630 mm (48" x 25")
- Maximum Working Pressure : 100 bar

### DRIVE SPECIFICATION

- Tube range 1/2" to 2" O.D. up to 5.1/2" thick tube sheets.
- Special expanders also available .
- No load RPM - 780.
- Control voltage - 24 volts DC.
- Thrust stroke - 65 mm.

**NOTE :** Optional stepping space for rolling thicker tube sheets without removing expander from the tube.  
Extension for expanding of tubes in deep channels is available.  
Ask for catalog number HTTE/038/1 for expanders available.  
System is supplied with operation manual showing detailed features and accessories.

# HYDRAULIC TUBE EXPANSION SYSTEMS (HYDEX)

## Features :

- 1) Drive communicates with the pump via 9v DC remote control. This ensures safety and eliminates the need of electrical cord between pump and drive that other manufacturers provide.
- 2) Silent during use. In comparison electric and pneumatic tube expansion systems are noisy.
- 3) Compact, therefore easy to use inside boiler drums.
- 4) Compatibility - Same powerpack for all the 4 drives to expand 5/8" o.d to 4" o.d tube.
- 5) Very High Torque Developed - can expand large diameter, thick wall tubes in thick tube sheets easily.
- 6) Long life + low maintenance.
- 7) Boiler erections get completed in record time.
- 8) Can be use for long working hours because drive is unaffected by heat.
- 9) Dual drive powerpack is available to connect 2 drives to a single powerpack to cut down tube expansion time cycle by a further 50%.
- 10) Microprocessor controls on the pump automate the expansion cycle. Trip, pause and reverse times for the drive are adjustable. No need for repeated manual STOP/START of the drive during the expansion cycle - completely automatic.
- 11) Drive speed remains constant during the expansion cycle unlike electric or pneumatic drives.

The hydraulic pump supplied with hydraulic drive incorporates the latest state of the art technology resulting in a subcompact pump developing 100 bar pressure. The system is mounted on four wheels for on site manoeuvrability. Expansion of tubes is regulated by adjusting pressure setting on pump. Once required amount of wall thinning is achieved the drive trips automatically.

**Powermaster offers you an unparalled choice of three different pumps based on your application and budget.**



## HYDRAULIC PUMP HEP-500



	Hydraulic Pump Models		
	HEP-300	HEP-500	HEP-1000 TWIN HEAD
Oil Tank Capacity (Litres)	30	45	138
Hydraulic Oil	SAE VG 68	SAE VG 68	SAE VG 68
Maximum Working Pressure ( bar)	100	100	100
Net Weight ( kgs)	80	100	220
Overall Dimensions (mm)	610 x 270 x 985	820 x 320 x 985	1775 x 550 x 1200
Electric Motor	3 hp. Single phase	5 hp. 3 phase	10 hp. 3 phase
Voltage	230 v / 110 v	415 v	415 v
Standard Hose Size (Length)	1/2" (10 mtrs.)	1/2" (10 mtrs.)	1/2" (10 mtrs.)

# ACCESSORIES FOR HYDRAULIC EXPANSION SYSTEMS



## HYDRAULIC DRIVES

Tube Expansion Range				Drive		Drive No Load Speed (RPM)	Drive Weight Kgs.
Steel Tube O.D.		Copper Tube O.D.		Model No.	Square Socket inch	With HEP-300/500/1000	
mm	inch	mm	inch				
15 - 25	5/8 - 1	25 - 38	1-1.1/2	HED-3	3/8	620/954/800	9.6
19 - 38	3/4 - 1.1/2	32 - 64	1.1/4-2.1/2	HED-4	3/8 & 1/2	350/480/400	9.7
38 - 76	1.1/2 - 3	50 - 102	2-4	HED-5	1/2 & 3/4	62/84/70	11.0
50 - 102	2 - 4	-	-	HED-6	3/4 & 1	40/62/54	11.5

**Note :** Drive supplied with FORWARD, STOP, REVERSE, AUTO BUTTONS, QUICK RELEASE COUPLINGS, SOCKETS and REACTION BAR. Powerpack includes 2 hoses each of length 10 meters. If required longer hoses can be supplied.

## HYDRAULIC HOSE



Model No.	Hydraulic Hose (Qty. x Size x Length) (Mtrs.)
HE/HS/1210/2	2 x 1/2" x 10
HE/HS/5815/2	2 x 5/8" x 15
HE/HS/5820/2	2 x 5/8" x 20
HE/HS/1210/4	4 x 1/2" x 10
HE/HS/5815/4	4 x 5/8" x 15
HE/HS/5820/4	4 x 5/8" x 20

## SUPPLY CABLE



Model No.	Supply Cable Length (Mtrs.)
HE/SC/15	15
HE/SC/20	20
HE/SC/25	25

## HYDRAULIC DRIVE SOCKET



Model No.	Square Size
HE/DS/38	3/8"
HE/DS/12	1/2"
HE/DS/34	3/4"
HE/DS/1	1"

# ACCESSORIES FOR HYDRAULIC EXPANSION SYSTEMS

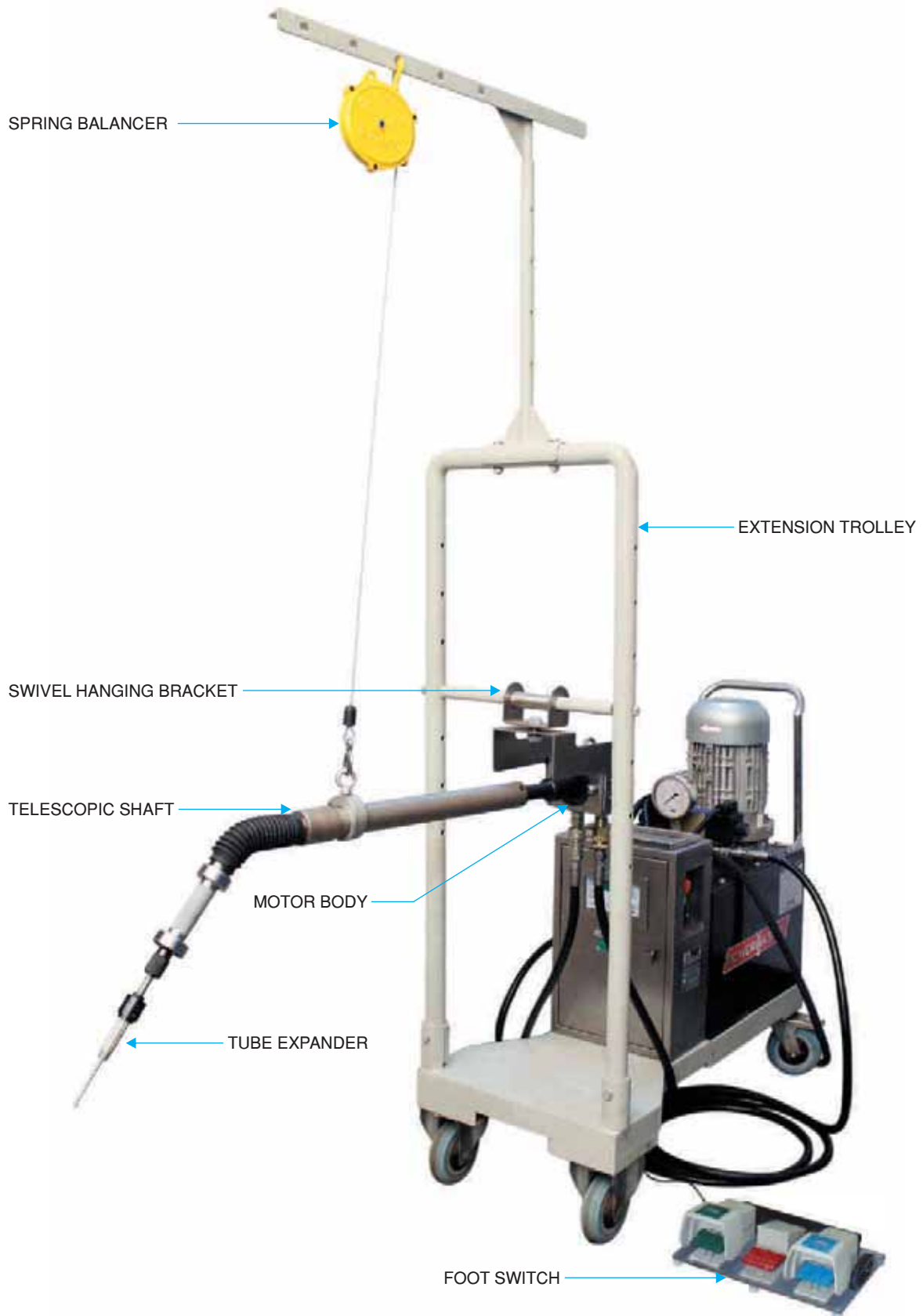

Model No.	Description
TS-1	Telescopic Shaft for HED-3
TS-2	Telescopic Shaft for HED-4
TS-3	Telescopic Shaft for HED-5
TS-4	Telescopic Shaft for HED-6
SWF-5	Spring Balancer
HE/FS/24	Foot Switch
HE/EXTR/3456	Extension Trolley
HE/HB/3456	Swivel Hanging Bracket

## PNEUMATIC ROLLING DRIVES



Pneumatic Rolling Drives are specifically designed to ensure uniform tube to tube sheet expansions, there by ensuring exact rolling of tubes.

### Features :

- Light weight aluminum body.
- Ergonomically correct push/pull throttle.
- Automatically stops tube expansion at defined setting.
- Precision control measures torque output.

Model Number	Free Speed rpm	Min Torque Nm	Max Torque Nm	Tube Capacity inch	Air Consumption l/min	Weight kg
720-550	550	0.226	8.47	1/2	480	1.20
850-1250	1250	1.58	12.20	3/4	1700	4.80
850-600	600	2.49	21.81	1	1700	4.80
850-400	400	5.00	36.00	1.1/4	1700	4.80

## RIGHT ANGLE ROLLING DRIVES



Right Angle Rolling Drives are specifically designed for expanding boiler tubes in steam, mud drums, fire tube & related boiler equipment.

### Features :

- Unique head design consisting of fully enclosed bearing for long & trouble free life.
- Both models equipped with roll throttle as standard. Lever throttle optional.
- Easy adjustable torque.
- Angle head can be setup in numerous positions.
- 360 degree adjustable air exhaust.

Model Number	Free Speed rpm	Min Torque Nm	Max Torque Nm	Tube Capacity inch	Square Drive inch	Weight kg
P72-RT-190	190	95	190	2.5	5/8	5.80
P72-RT-90	90	200	410	4	3/4	6.70





# TUBE INSTALLATION TOOLS

Page 31-44



$\frac{3}{8}$ " -  $2\frac{1}{2}$ "  
O.D.

## SERRATING / GROOVING TOOL - 'ST' SERIES

FOR GROOVING IN TUBE SHEETS



TOOL BITS



1/8" x 3/8" x 1/8"



1/8" x 1/4" x 1/8"

- Features :*
- High production tool.
  - Ideal for use where 1 tool is needed per bore.
  - One piece cryogenically treated tool bit ensures maximum life.
  - Tool is ideally suited for CNC applications on account of 1 piece mandrel construction and short design.

Tube O.D.		Tool Model No.	Spare Tool Bits		
mm	inch		1/8" x 3/8" x 1/8" Spacing	1/8" x 1/4" x 1/8" Spacing	Special Spacing
9.53	3/8	ST-375-970	ST-3703	ST-3703-S	ST-3703-SPEC
12.70	1/2	ST-500-1270	ST-5003	ST-5003-S	ST-5003-SPEC
15.87	5/8	ST-625-1588	ST-6203	ST-6203-S	ST-6203-SPEC
19.05	3/4	ST-750-1900	ST-7503	ST-7503-S	ST-7503-SPEC
22.22	7/8	ST-875-2220	ST-7503	ST-7503-S	ST-7503-SPEC
25.40	1	ST-1000-2540	ST-7503	ST-7503-S	ST-7503-SPEC
31.75	1.1/4	ST-1250-3175	ST-7503	ST-7503-S	ST-7503-SPEC
38.10	1.1/2	ST-1500-3810	ST-7503	ST-7503-S	ST-7503-SPEC
50.80	2	ST-2000-5080	ST-7503	ST-7503-S	ST-7503-SPEC
63.50	2.1/2	ST-2500-6350	ST-7503	ST-7503-S	ST-7503-SPEC

**Note :** Serrating Tools are available for MM bore sizes also. Please enquire.  
Refer to operation manual for spare parts list and detailed features.

$\frac{3}{8}$ " - 4"  
O.D.

## SERRATING / GROOVING TOOL - 'NW' SERIES



**CIRCULAR FORM CUTTER**



**TOOL BIT HOLDER WITH TOOLBIT**

- Features :*
- Changing of pilot nose and cutter allows one tool to cover a range of hole diameters.
  - Simple to change cutter for different groove shapes.
  - Location and depth of cut easy to adjust.
  - Only light pressure required to cut precision grooves.
  - Ready to fit CNC drill machines, lathes and boring machines.
  - The life of the cutter extendable by re-sharpening.

Bore Range		Tool Model No.	Pilot Nose Model No.	Circular Form Cutter Model No.	Tool Bit Holder Model No.	Spare Tool Bit Model No.
mm	inch					
9 - 32	3/8 - 1.1/4	1 NW - 2 MT	1 NW - PN	1 NW - CF	1 NW - TBH	1 NW - TB
16 - 45	5/8 - 1.3/4	3 NW - 3 MT	3 NW - PN	3 NW - CF	3 NW - TBH	3 NW - TB
19 - 48	3/4 - 1.7/8	4 NW - 4 MT	4 NW - PN	4 NW - CF	4 NW - TBH	4 NW - TB
38 - 102	1.1/2 - 4	6 NW - 5 MT	6 NW - PN	6 NW - CF	6 NW - TBH	6 NW - TB

**Note :** Specify whether you need Circular Form Cutter (one piece HSS construction) or Tool Bit Holder with Tool Bit, when ordering.  
Refer to operation manual for detailed spare parts list.  
Ask for leaflet number 038 for detailed features.

# SERRATING / GROOVING TOOL - 'SGT' SERIES

$\frac{3}{8}$ " - 3"  
O.D.



TOOL BIT

### Features :

- Only light pressure required to cut precision grooves inside holes or cylinders.
- Location and depth of groove easy to adjust.
- Simple to change cutter for different groove shapes.
- Changing of bushing and cutter allows one tool to cover a range of hole diameters.
- The life of the cutter extendable by re-sharpening.

Bore Range		Tool Model No.	Pilot Nose / Bushing Model No.	Tool Bits Model No.
mm	inch			
10 - 13	0.40 - 0.51	SGT-102	SGT-102-PN	SGT-102-TB
12.7 - 16	0.50 - 0.63	SGT-122	SGT-122-PN	SGT-122-TB
16 - 20	0.63 - 0.79	SGT-162	SGT-162-PN	SGT-162-TB
19 - 32	0.75 - 1.26	SGT-193	SGT-193-PN	SGT-193-TB
30 - 52	1.18 - 2.05	SGT-303	SGT-303-PN	SGT-303-TB
50 - 78	1.97 - 3.07	SGT-504	SGT-504-PN	SGT-504-TB

**Note :** Ask for catalog number CTG-100 for spare parts list, operating instructions and detailed features.

**PLEASE SUPPLY FOLLOWING INFORMATION WHEN ORDERING GROOVING TOOLS OR SPARE CUTTERS.**

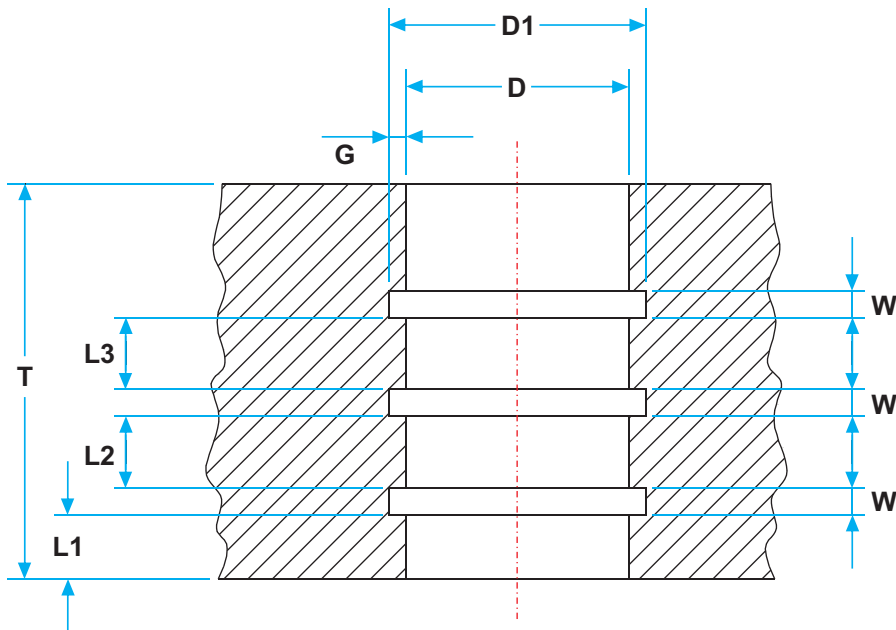

A)	Bore Dia after reaming with Tolerances	D
B)	Tube Plate Thickness	T
C)	Distance of First Groove	L1
D)	Total Number of Grooves	N
E)	Spacing of Grooves	L2, L3
F)	Groove Width	W
G)	Diameter of Grooves	D1
H)	Groove undercut Depth	G



**TUBE SHEET HOLE REAMER**



*Features :*

- High speed steel, cryogenically treated & coated with Titanium Nitride for long life.
- Ideal for heat exchanger and condenser tube sheet reaming.
- Reamers available in MM sizes also.
- For larger diameters, please enquire.

Tube O.D.		Reamer Size to "TEMA" Specification		Model No.	Flute Length		OAL		Shank: Morse Taper #
mm	inch	mm	inch		mm	inch	mm	inch	
9.53	3/8	9.65	.380	RM-095/66	66	2.60	146	5.70	1
				RM-095/101	101	3.97	181	7.12	
				RM-095/152	152	5.98	232	9.13	
12.70	1/2	12.83	.505	RM-127/76	76	2.99	156	6.14	1
				RM-127/101	101	3.97	181	7.12	
				RM-127/152	152	5.98	232	9.13	
15.87	5/8	16.03	.631	RM-158/87	87	3.42	187	7.36	2
				RM-158/152	152	5.98	252	9.92	
				RM-158/203	203	7.99	303	11.93	
16.00	-	16.16	.636	RM-160/87	87	3.42	187	7.36	2
				RM-160/152	152	5.98	252	9.92	
				RM-160/203	203	7.99	303	11.93	
19.05	3/4	19.25	.758	RM-190/100	100	3.90	200	7.87	2
				RM-190/152	152	5.98	252	9.92	
				RM-190/203	203	7.99	303	11.93	
20.00	-	20.20	.795	RM-200/100	100	3.90	200	7.87	2
				RM-200/152	152	5.98	252	9.92	
				RM-200/203	203	7.99	303	11.93	
22.00	-	22.22	.875	RM-220/107	107	4.21	207	8.15	2
				RM-220/152	152	5.98	252	9.92	
				RM-220/203	203	7.99	303	11.93	
22.22	7/8	22.42	.883	RM-222/107	107	4.21	207	8.15	2
				RM-222/152	152	5.98	252	9.92	
				RM-222/203	203	7.99	303	11.93	
25.00	-	25.25	.994	RM-250/115	115	4.53	242	9.53	3
				RM-250/203	203	7.99	330	12.99	
				RM-250/254	254	10.00	381	15.00	
25.40	1	25.65	1.010	RM-254/115	115	4.53	242	9.53	3
				RM-254/203	203	7.99	330	12.99	
				RM-254/254	254	10.00	381	15.00	
28.57	1.1/8	28.86	1.136	RM-285/124	124	4.88	251	9.88	3
				RM-285/203	203	7.99	330	12.99	
				RM-285/254	254	10.00	381	15.00	
31.75	1.1/4	32.07	1.262	RM-317/133	133	5.23	293	11.53	4
				RM-317/203	203	7.99	363	14.29	
				RM-317/254	254	10.00	414	16.30	

## TUBE END FACER - 'TEF' SERIES

3/8" - 2 1/2"  
O.D.



### Features :

- Tool bits coated with Titanium Nitride to give 3 times the life of conventional tool bits.
- Ideal for quick facing of projecting tube ends in heat exchangers, condensers and boilers.
- One size of tool is suitable for use on multiple tube thicknesses by interchanging pilot. (TEF-375 is the exception with the tool suitable for one tube ID only).
- Each tool is supplied with a set of multiple pilots to cover all tube thicknesses.
- Tube end facers for MM sizes of tubes also available. Please enquire.

Tube O.D.		Tube Thk. bwg	Model No.	Spare Tool Bits	
mm	inch			Non-Ferrous or Carbon Steel Tubes Model No.	Stainless Steel Tubes Model No.
9.53	3/8	16-22	TEF-375	TEF-376	TEF-376 SS
12.70	1/2	15-20	TEF-500	TEF-506	TEF-506 SS
15.87	5/8	14-18	TEF-625	TEF-626	TEF-626 SS
19.05	3/4	10-18	TEF-750	TEF-756	TEF-756 SS
22.22	7/8	13-18	TEF-875	TEF-876	TEF-876 SS
25.40	1	11-18	TEF-1000	TEF-1006	TEF-1006 SS
28.57	1.1/8	11-18	TEF-1125	TEF-1126	TEF-1126 SS
31.75	1.1/4	11-18	TEF-1250	TEF-1256	TEF-1256 SS
34.92	1.3/8	11-18	TEF-1375	TEF-1376	TEF-1376 SS
38.10	1.1/2	11-18	TEF-1500	TEF-1506	TEF-1506 SS
41.27	1.5/8	11-18	TEF-1625	TEF-1626	TEF-1626 SS
44.45	1.3/4	11-18	TEF-1750	TEF-1756	TEF-1756 SS
47.62	1.7/8	11-18	TEF-1875	TEF-1876	TEF-1876 SS
50.80	2	11-18	TEF-2000	TEF-2006	TEF-2006 SS
57.15	2.1/4	11-18	TEF-2250	TEF-2256	TEF-2256 SS
63.50	2.1/2	11-18	TEF-2500	TEF-2506	TEF-2506 SS

## TUBE END FACER - 'FB' SERIES



### Features :

- High speed production tool.
- Titanium Nitride coated tool bit can be reversed and used. Doubles tool bit life.

Tube O.D.		Tube Thk. bwg	Model No.	Spare Tool Bits	
mm	inch			Non-Ferrous or Carbon Steel Tubes Model No.	Stainless Steel Tubes Model No.
9.53	3/8	16-22	FB-375	FB-376	FB-376 SS
12.70	1/2	15-20	FB-500	FB-506	FB-506 SS
15.87	5/8	14-18	FB-625	FB-626	FB-626 SS
19.05	3/4	10-18	FB-750	FB-756	FB-756 SS
22.22	7/8	13-18	FB-875	FB-876	FB-876 SS
25.40	1	11-18	FB-1000	FB-1006	FB-1006 SS
28.57	1.1/8	11-18	FB-1125	FB-1126	FB-1126 SS
31.75	1.1/4	11-18	FB-1250	FB-1256	FB-1256 SS
34.92	1.3/8	11-18	FB-1375	FB-1376	FB-1376 SS
38.10	1.1/2	11-18	FB-1500	FB-1506	FB-1506 SS
41.27	1.5/8	11-18	FB-1625	FB-1626	FB-1626 SS
44.45	1.3/4	11-18	FB-1750	FB-1756	FB-1756 SS
47.62	1.7/8	11-18	FB-1875	FB-1876	FB-1876 SS
50.80	2	11-18	FB-2000	FB-2006	FB-2006 SS
57.15	2.1/4	11-18	FB-2250	FB-2256	FB-2256 SS
63.50	2.1/2	11-18	FB-2500	FB-2506	FB-2506 SS

**TUBE END FACER - 'FC' SERIES / WELD REMOVAL TOOL**

Tube O.D.		Facer Fitted With 3 Tool Bits Model No.	Spare Tool Bits Model No.
mm	inch		
38.10	1.1/2	FC-1500	FC-1500-TB
41.27	1.5/8	FC-1625	FC-1625-TB
44.45	1.3/4	FC-1750	FC-1750-TB
47.62	1.7/8	FC-1875	FC-1875-TB
50.80	2	FC-2000	FC-2000-TB
57.15	2.1/4	FC-2250	FC-2250-TB
63.50	2.1/2	FC-2500	FC-2500-TB
69.85	2.3/4	FC-2750	FC-2750-TB
76.20	3	FC-3000	FC-3000-TB
82.55	3.1/4	FC-3250	FC-3250-TB
88.90	3.1/2	FC-3500	FC-3500-TB
95.25	3.3/4	FC-3750	FC-3750-TB
101.6	4	FC-4000	FC-4000-TB



*Features :*

- Tool uses 3 cutting blades which can be configured for tube end facing or weld removal as a step in the removal of welded tubes from the tube sheet.
- Tool fitted with MT shank for use with standard air or electric drills.
- Cutting blades are Titanium Nitride coated to give 3 times the life of conventional cutting blades.
- Tools available for MM sizes of tubes also. Please enquire.
- Ideally suited for work on larger diameter boiler tubes.

**FLARING TOOL**

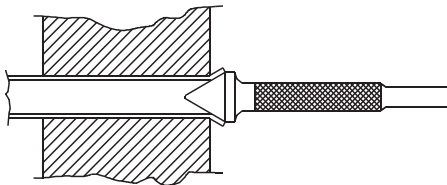

Tube O.D.		Tube Thk. bwg.	Model No.
mm	inch		
12.70	1/2	16-22	FT-1
15.87	5/8	14-15	FT-2
		16-22	FT-3
19.05	3/4	14-15	FT-4
		16-22	FT-5
22.22	7/8	14-15	FT-6
		16-22	FT-7
25.40	1	12-15	FT-8
		16-22	FT-9
28.57	1.1/8	12-15	FT-10
		16-22	FT-11
31.75	1.1/4	8-14	FT-12
		15-22	FT-13
34.92	1.3/8	8-14	FT-14
		15-22	FT-15
38.10	1.1/2	8-14	FT-16
		15-22	FT-17

**TUBE SHEET HOLE RADIUS CUTTER**

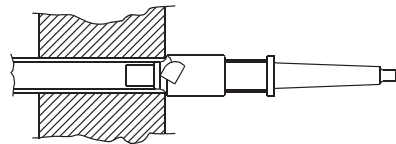

- High speed steel tool used in preparing tube sheets to suit the flaring or beading of tube ends outside of or flush with the tube sheet.
- MM sizes and cutters with other radii are also available. Please enquire.

Tube O.D.		Model No.	Tool Radius		Morse Taper
mm	inch		mm	inch	
12.70	1/2	20338	3.2	1/8	2
15.87	5/8	20224	4.0	5/32	2
19.05	3/4	20225	4.8	3/16	2
22.22	7/8	20226	4.8	3/16	2
25.40	1	20227	4.8	3/16	2
28.57	1.1/8	40512	6.4	1/4	2
31.75	1.1/4	21395	6.4	1/4	2

**Note :** Fitted with Type 1 round shank for use with standard pneumatic chipping hammer. Other shanks on request.

## TUBE SHEET HOLE BRUSH

1/2" - 3"  
O.D.



- To clean tube sheet bores, prior to tube installation.
- Can be used with any standard pneumatic or electric drill.

Tube O.D.		Model No.
mm	inch	
12.70	1/2	TSHB-1/2
15.87	5/8	TSHB-5/8
19.05	3/4	TSHB-3/4
22.22	7/8	TSHB-7/8
25.40	1	TSHB-1
31.75	1.1/4	TSHB-1.1/4
38.10	1.1/2	TSHB-1.1/2
44.45	1.3/4	TSHB-1.3/4
50.80	2	TSHB-2
57.15	2.1/4	TSHB-2.1/4
63.50	2.1/2	TSHB-2.1/2
69.85	2.3/4	TSHB-2.3/4
76.20	3	TSHB-3

**Note :** Available in your choice of carbon steel, stainless steel or brass. For other / larger sizes, please enquire.

## TUBE GUIDE

1/2" - 3"  
O.D.



- To 'pilot' the tubes through the tube sheets and baffle plates during tube insertion.

Tube O.D.		Tube Thk. bwg.	Model No.	Tube O.D.		Tube Thk. bwg.	Model No.
mm	inch			mm	inch		
12.70	1/2	16-18	PTG-1	31.75	1.1/4	10-13	PTG-15
		19-20	PTG-2			14-20	PTG-16
		21-23	PTG-2.5			8-9	PTG-17
15.87	5/8	12-13	PTG-3	34.92	1.3/8	10-13	PTG-18
		14-16	PTG-4			14-20	PTG-19
		17-20	PTG-5			8-9	PTG-20
		22-24	PTG-5.5			10-13	PTG-21
19.05	3/4	10-12	PTG-6	38.10	1.1/2	14-20	PTG-22
		13-16	PTG-7			8-10	PTG-23
		17-20	PTG-8			11-13	PTG-24
		22-24	PTG-8.5			14-18	PTG-25
22.22	7/8	10-12	PTG-9	50.80	2	10-13	PTG-26
		13-16	PTG-10			14-18	PTG-27
		17-20	PTG-11				
		21-22	PTG-11.5				
25.40	1	8-9	PTG-12.5	63.50	2.1/2		
		10-12	PTG-12				
		13-16	PTG-13				
		17-20	PTG-14				
31.75	1.1/4	21-23	PTG-14.5				
		10-13	PTG-15				
		14-20	PTG-16				

**Note :** For other / larger sizes, please enquire.

# TUBE LEAK DETECTOR KIT

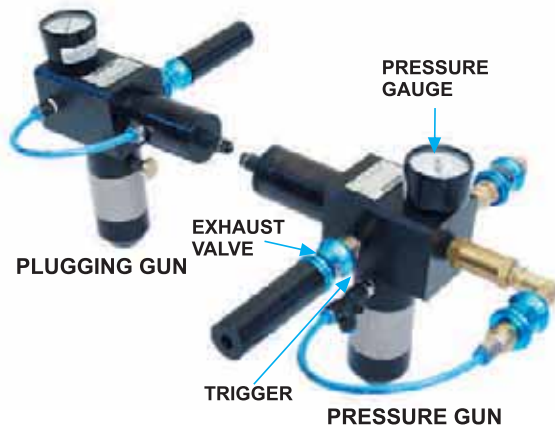

## Features :

- Simple, Quick and Reliable tube testing. Test 7 to 8 tubes per minute.
- Interchangeable seal sets : Allows testing of tubes from 7.75 mm to 30.63 mm ID with easy to replace accessories.
- Each Tube Testing Gun weighs less than 1.3 kg.
- Air supply : Uses standard plant air supplies from 70 psi to 100 psi (4.7 to 6.8 bar).
- Silent during use. Ergonomic design makes testing effortless.
- Each Kit packed in compact and handy case.

## SEQUENCE OF OPERATION

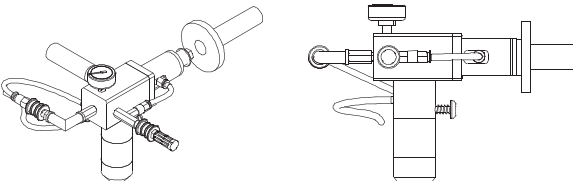
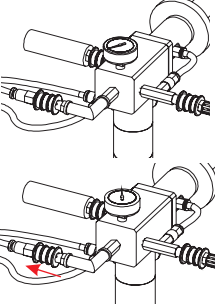
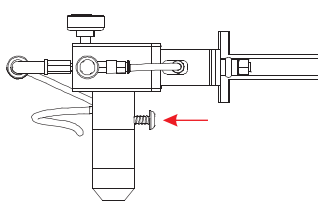
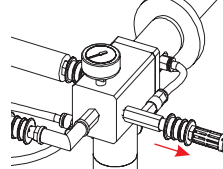
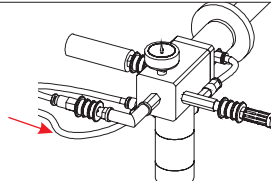
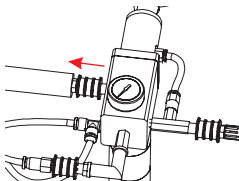
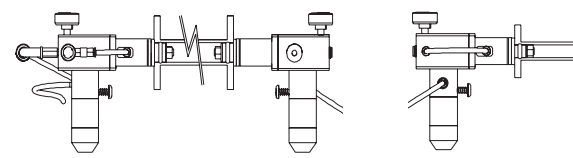
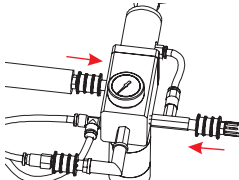
 <p>A) Insert tube seal of Pressure gun into tube to be tested. The cover must rest firmly on tube end surface. Tube seal is in COLLAPSED state when inserting.</p>	 <p>E) GRADUALLY pressurise tube by sliding tube pressurising valve to right. Allow tube pressure to build up to 5-6 bar. This is indicated on pressure gauges on both guns. Slide tube pressurising valve from right to left to stop pressurising tube once 5-6 bar pressure is reached in the tube. Monitor pressure gauge for few seconds to find leakage in tube. Pressure drop indicated in pressure gauge indicates a leakage in tube. Stable pressure indication in pressure gauge indicates a healthy non-leaky tube.</p>
 <p>B) Press Trigger of Pressure gun to bulge seal. A proper size seal will grip into tube inner diameter.</p>	 <p>F) After test, first exhaust the tube pressure by sliding left to right tube exhaust valve on Pressure gun. <b>NOTE :</b> DO NOT slide the seal exhaust valve before de pressurising the tube. The gun will be thrown out if the seal collapses while air pressure still exists in the tube.</p>
 <p>C) Operator holding the Pressure gun can blow air through the tube to help the Plugging gun operator identify the tube being tested. Sliding pressurising valve from left to right as shown in the picture blows air.</p>	 <p>G) Withdraw both the guns after collapsing the tube seal using tube seal exhaust valve.</p>
 <p><b>PRESSURE GUN    PLUGGING GUN    PLUGGING GUN</b></p> <p>D) Once Plugging gun operator identifies tube, stop blowing air to allow Plugging gun to be inserted into identified tube. Press Trigger of Plugging gun to expand Plugging gun seal. Press Trigger of Pressure gun to expand seal.</p>	 <p>H) Close tube seal exhaust valve in both guns by sliding back from left to right. Close tube exhaust valve by sliding right to left. The guns are now prepared to test the next tube.</p>



# TUBE LEAK DETECTOR KIT SPECIFICATIONS

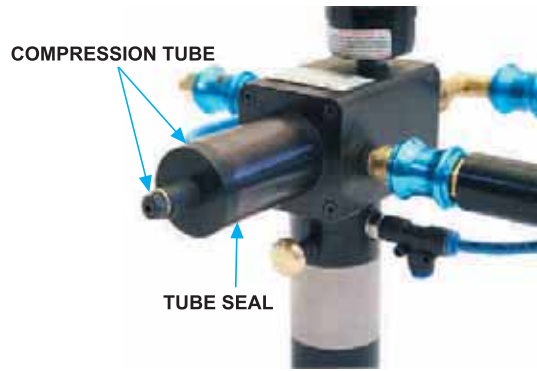

Tube Size		Tube ID Range		Tube Seal Part No.	Tube Seal Diameter		Compression Tube Part No.
O.D.	bwg	mm	inch		mm	inch	
5/8"	9	8.37	.330	TLD-300N	7.5	.295	TLD-15-125
	10-13	9.07 - 11.05	.357 - .435	TLD-370N	9	.354	
	14-15	11.67 - 12.23	.459 - .481	TLD-450N	11.6	.457	
	16-17	12.57 - 12.93	.495 - .509	TLD-470N	12.2	.480	TLD-15-312
	18-19	13.39 - 13.75	.527 - .541	TLD-490N	13.3	.523	
	20-24	14.11 - 14.77	.555 - .581	TLD-530N	13.8	.543	
3/4"	9	11.55	.455	TLD-430N	10.8	.425	TLD-15-312
	10 - 11	12.25 - 12.95	.482 - .510	TLD-450N	11.6	.457	TLD-15-125
	12 - 13	13.53 - 14.23	.532 - .560	TLD-490N	13.3	.523	TLD-15-312
	14 - 15	14.85 - 15.41	.584 - .606	TLD-530N	13.8	.543	
	16 - 17	15.75 - 16.11	.620 - .634	TLD-570N	15.4	.606	
		18 - 19	16.57 - 16.93	.652 - .666	TLD-610N	16.5	.649
	20 - 24	17.29 - 17.95	.680 - .706	TLD-650N	17.0	.669	TLD-15-405
7/8"	8-9	13.84 - 14.72	.544 - .579	TLD-530N	13.8	.543	TLD-15-312
	10-11	15.42 - 16.12	.607 - .635	TLD-570N	15.4	.606	
	12-13	16.7 - 17.4	.657 - .685	TLD-610N	16.5	.649	
	14-15	18.02 - 18.58	.709 - .731	TLD-690N	18	.708	TLD-15-405
	16-17	18.92 - 19.28	.745 - .759	TLD-730N	18.6	.732	
		18-19	19.74 - 20.1	.777 - .791	TLD-740N	19.7	.775
	20-24	20.46 - 21.12	.805 - .831	TLD-790N	20.1	.791	
1"	8-9	17.02 - 17.9	.670 - .704	TLD-650N	17	.669	TLD-15-405
	10-11	18.6 - 19.3	.732 - .760	TLD-690N	18	.708	TLD-15-312
	12-13	19.88 - 20.58	.782 - .810	TLD-740N	19.7	.775	
	14-15	21.2 - 21.76	.834 - .856	TLD-790N	20.1	.791	
	16-17	22.1 - 22.46	.870 - .884	TLD-840N	21.7	.854	TLD-15-405
	18-19	22.92 - 23.28	.902 - .916	TLD-870N	22.9	.901	
	20-24	23.64 - 24.3	.930 - .956	TLD-890N	23.3	.917	
1.1/8"	8-9	20.19 - 21.07	.795 - .829	TLD-790N	20.1	.791	TLD-15-312
	10-11	21.77 - 22.47	.857 - .884	TLD-840N	21.7	.854	TLD-15-405
	12-13	23.05 - 23.75	.907 - .935	TLD-870N	22.9	.901	
	14-15	24.37 - 24.93	.959 - .981	TLD-890N	23.3	.917	
	16-17	25.27 - 25.63	.994 - 1.009	TLD-980N	25.2	.992	TLD-15-405
	18-19	26.09 - 26.45	1.027 - 1.041	TLD-990N	26.0	1.024	
	20-24	26.81 - 27.47	1.055 - 1.081	TLD-1040N	26.8	1.055	
1.1/4"	8-11	23.37 - 25.65	.920 - 1.01	TLD-890N	23.3	.917	TLD-15-405
	12-13	26.23 - 26.93	1.032 - 1.060	TLD-990N	26.0	1.024	
	14-17	27.55 - 28.81	1.084 - 1.134	TLD-1090N	27.5	1.082	
	18-24	29.27 - 30.65	1.152 - 1.206	TLD-1100N	29.2	1.149	

# TUBE TO TUBE SHEET JOINT TESTING KIT

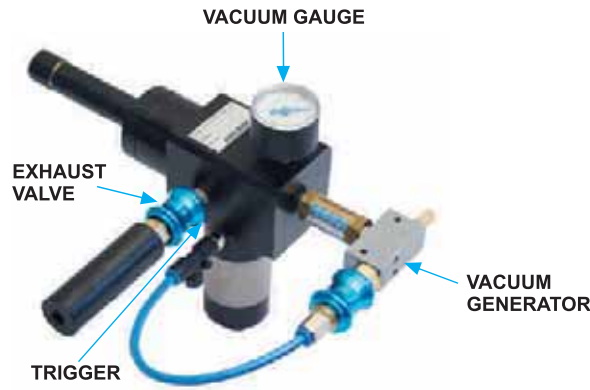

## Features :

- Simple, Quick and Reliable tube joint testing. Test 10 tube joints per minute.
- Interchangeable seal sets : Allows testing of tube joints from 7.75 mm to 30.63 mm ID with easy to replace accessories.
- Joint Testing Gun weights less than 1.5 kg.
- Air supply : Uses standard plant air supplies from 70 psi to 100 psi (4.7 to 6.8 bar).
- Silent during use. Ergonomic design makes testing effortless.
- Each Kit packed in compact and handy case.

## SEQUENCE OF OPERATION

<p>A) Close exhaust valve by sliding to extreme right</p>	<p>D) Slide vacuum valve to right to start generating vacuum. Gauge will indicate vacuum level.</p>
<p>B) Insert manifold till square o-ring firmly sits on tube</p>	<p>E) Close vacuum slide valve by shifting to left. This will stop vacuum generation. Observe vacuum gauge. Vacuum level falls if the joint is leaking.</p>
<p>C)</p>	<p>F) After testing the joint release the tube seal by sliding the exhaust to the left. The Joint Testing Kit can be withdrawn after the tube seal collapses.</p>

# TUBE TO TUBE SHEET JOINT TESTING KIT SPECIFICATIONS

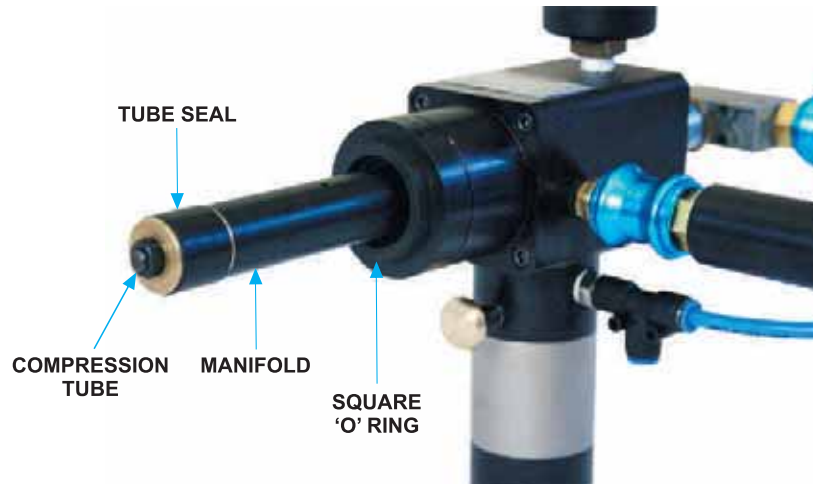

Tube Size		Tube ID Range		Tube Seal Part No.	Tube Seal Diameter		Manifold with Square O ring	Compression Tube Part No.	Square O ring
O.D.	bwg	mm	inch		mm	inch			
5/8"	9	8.37	.330	JTK- 300N	7.5	.295	JTM-15-125-5/8	JTK-15-125	JTK-16-5/8
	10-13	9.07 - 11.05	.357 - .435	JTK-370N	9	.354			
	14-15	11.67 - 12.23	.459 - .481	JTK-450N	11.6	.457			
	16-17	12.57 - 12.93	.495 - .509	JTK-470N	12.2	.480			
	18-19	13.39 - 13.75	.527 - .541	JTK-490N	13.3	.523			
	20-24	14.11 - 14.77	.555 - .581	JTK-530N	13.8	.543			
3/4"	9	11.55	.455	JTK-430N	10.8	.425	JTM-15-312-3/4-1	JTK-15-312	JTK-16-3/4
	10 - 11	12.25 - 12.95	.482 - .510	JTK-450N	11.6	.457	JTM-15-125-3/4	JTK-15-125	
	12 - 13	13.53 - 14.23	.532 - .560	JTK-490N	13.3	.523	JTM-15-312-3/4-2	JTK-15-312	
	14 - 15	14.85 - 15.41	.584 - .606	JTK-530N	13.8	.543			
	16 - 17	15.75 - 16.11	.620 - .634	JTK-570N	15.4	.606			
	18 - 24	16.57 - 17.95	.652 - .706	JTK-610N	16.5	.649			
7/8"	8-9	13.84 - 14.72	.544 - .579	JTK-530N	13.8	.543	JTM-15-312-7/8-1	JTK-15-312	JTK-16-7/8
	10-11	15.42 - 16.12	.607 - .635	JTK-570N	15.4	.606			
	12-13	16.7 - 17.4	.657 - .685	JTK-610N	16.5	.649			
	14-17	18.02 - 19.28	.709 - .759	JTK-690N	18	.708	JTM-15-312-7/8-2		
	18-19	19.74 - 20.1	.777 - .791	JTK-740N	19.7	.775			
	20-24	20.46 - 21.12	.805 - .831	JTK-790N	20.1	.791			
1"	8-9	17.02 - 17.9	.670 - .704	JTK-610N	16.5	.649	JTM-15-312-1	JTK-15-312	JTK-16-1
	10-11	18.6 - 19.3	.732 - .760	JTK-690N	18	.708			
	12-13	19.88 - 20.58	.782 - .810	JTK-740N	19.7	.775			
	14-15	21.2 - 21.76	.834 - .856	JTK-790N	20.1	.791			
	16-17	22.1 - 22.46	.870 - .884	JTK-840N	21.7	.854	JTM-15-405-1		
	18-19	22.92 - 23.28	.902 - .916	JTK-870N	22.9	.901			
	20-24	23.64 - 24.3	.930 - .956	JTK-890N	23.3	.917			
1.1/8"	8-9	20.19 - 21.07	.795 - .829	JTK-790N	20.1	.791	JTM-15-312-1.1/8	JTK-15-312	JTK-16-1.1/8
	10-11	21.77 - 22.47	.857 - .884	JTK-840N	21.7	.854	JTM-15-405-1.1/8	JTK-15-405	
	12-13	23.05 - 23.75	.907 - .935	JTK-870N	22.9	.901			
	14-15	24.37 - 24.93	.959 - .981	JTK-890N	23.3	.917			
	16-17	25.27 - 25.63	.994 - 1.009	JTK-980N	25.2	.992			
	18-19	26.09 - 26.45	1.027 - 1.041	JTK-990N	26.0	1.024			
	20-24	26.81 - 27.47	1.055 - 1.081	JTK-1040N	26.8	1.055			
1.1/4"	8-11	23.37 - 25.65	.920 - 1.01	JTK-890N	23.3	.917	JTM-15-405-1.1/4	JTK-15-405	JTK-16-1.1/4
	12-13	26.23 - 26.93	1.032 - 1.060	JTK-990N	26.0	1.024			
	14-17	27.55 - 28.81	1.084 - 1.134	JTK-1090N	27.5	1.082			
	18-24	29.27 - 30.65	1.152 - 1.206	JTK-1100N	29.2	1.149			

TUBE / PIPE BEVELLING MACHINES

FM-1625

The FM-1625 is light weight and powerful machine for facing, beveling, and weld preparation. It is compact, easy to handle and quick to setup. It is used for jobs in restricted access areas. Used in shutdown environments on condensers and heat exchangers.

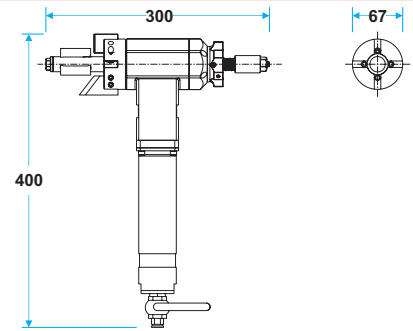

Drive	Pneumatic	Electric
Locking Range (mm)	20 - 42	20 - 42
Ideal Speed (RPM)	400	250
Torque (Nm)	27.5	45.0
Feeding Stroke (mm)	23	23
Pneumatic Power (HP)	0.60	--
Air Consumption (cfm)	16	--
Air Pressure (psi)	90	--
Electric Power (watts)	--	650
Weight (kg)	5.5	5.5

CUTTING BITS

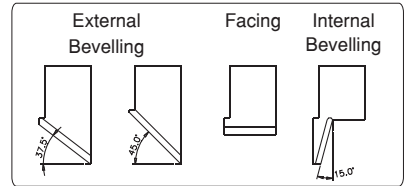

FM-3000

The FM-3000 the most popular and powerful machine. Used during maintenance and new boiler manufacturing. Quick interchangeability of locking jaws to suit wide range of dia meters. Modular and ergonomic design.

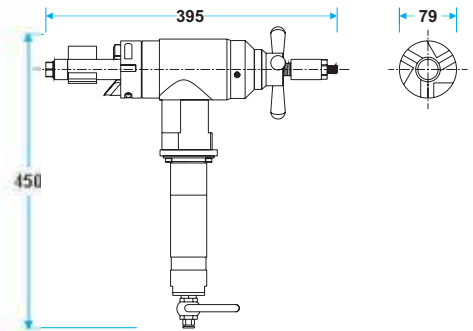

Drive	Pneumatic	Electric
Locking Range (mm)	28 - 76	28 - 76
Ideal Speed (RPM)	110	140
Torque (Nm)	84	138
Feeding Stroke (mm)	40	40
Pneumatic Power (HP)	0.83	--
Air Consumption (cfm)	42	--
Air Pressure (psi)	90	--
Electric Power (watts)	--	595
Weight (kg)	9.5	11.0

CUTTING BITS

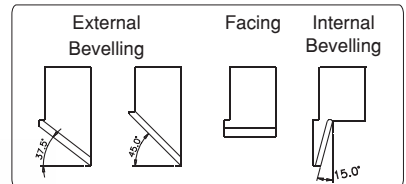

FM-4500

The FM-4500 is a heavy duty machine designed to bevel, face and prepare weld edges for heavy wall thickness tubes. Modular and ergonomic design.

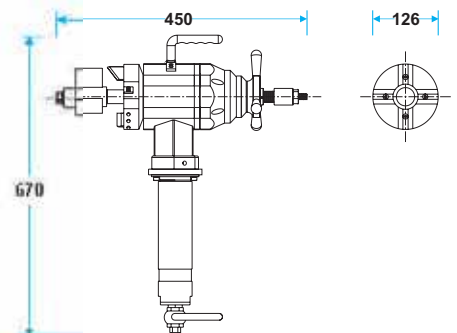

Drive	Pneumatic	Electric
Locking Range (mm)	39 - 104	39 - 104
Ideal Speed (RPM)	60	60
Torque (Nm)	220	240
Feeding Stroke (mm)	40	40
Pneumatic Power (HP)	1.3	--
Air Consumption (cfm)	40	--
Air Pressure (psi)	90	--
Electric Power (watts)	--	1800
Weight (kg)	21.0	23.0

CUTTING BITS

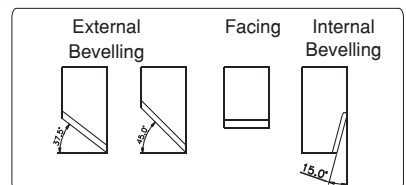

# TUBE / PIPE BEVELLING MACHINES

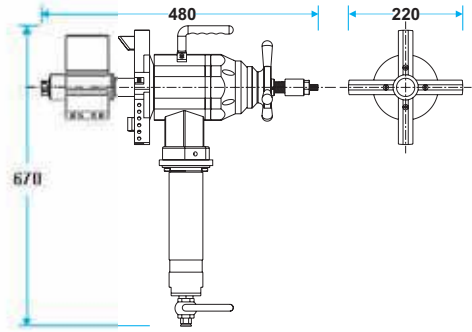

## FM-8000

The FM-8000 is a heavy duty machine suitable for use on a wide range of tube I.D's. Designed to bevel, face and produce weld preps on any thickness pipe or tube. Modular and ergonomic design with high torque to suit in toughest working condition.

Drive	Pneumatic	Electric
Locking Range (mm)	51 - 203	51 - 203
Ideal Speed (RPM)	40	40
Torque (NM)	220	240
Feeding Stroke (mm)	40	40
Pneumatic Power (HP)	1.3	--
Air Consumption (cfm)	40	--
Air Pressure (psi)	90	--
Electric Power (watts)	--	1800
Weight (Kg)	26.5	30.0

### CUTTING BITS

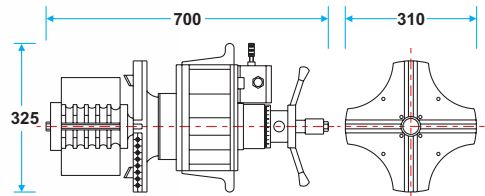
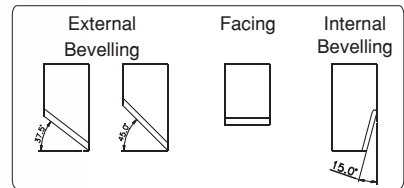

## FM-12000

The FM-12000 is a combination of power and range in a light and portable design. Wide range for tube end facing, beveling, counter boring and weld edge preparation. Rugged and balanced machine suitable for all sizes of tube and pipes.

Drive	Pneumatic	Electric
Locking Range (mm)	100 - 306	100 - 306
Ideal Speed (RPM)	35	31
Torque (Nm)	180	230
Feeding Stroke (mm)	50	50
Pneumatic Power (HP)	1.9	--
Air Consumption (cfm)	60	--
Air Pressure (psi)	90	--
Electric Power (watts)	--	1400
Weight (kg)	43.0	44.0

### CUTTING BITS

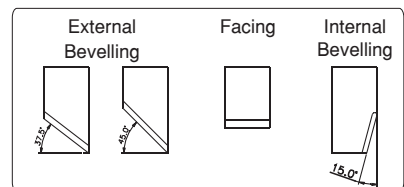

TUBE BUNDLE INSERTER

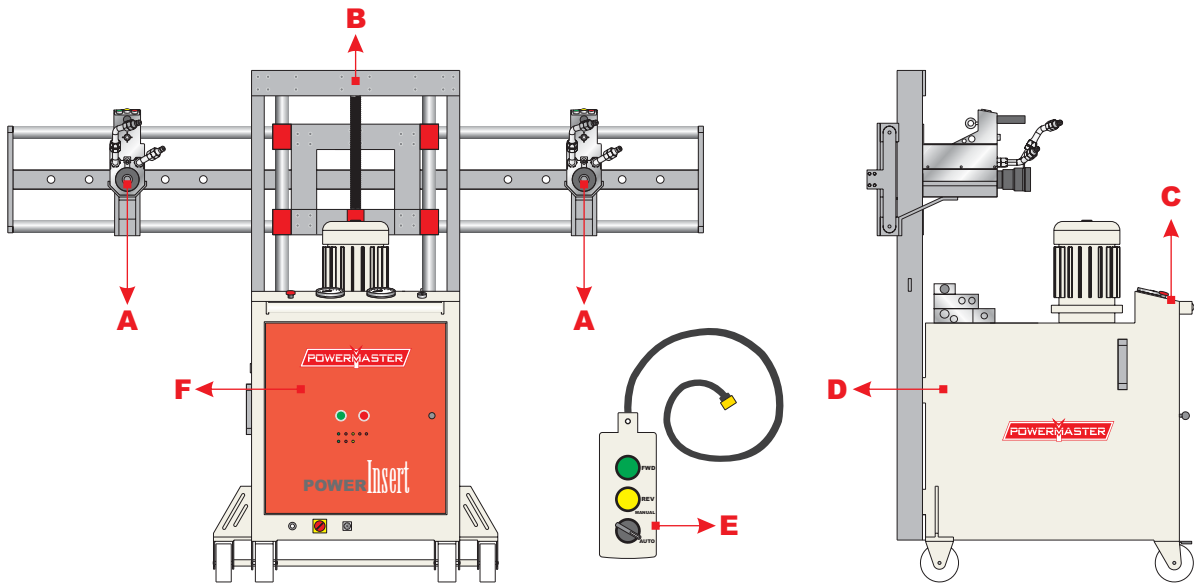

A	Fully Automatic Hydraulic Pistons
B	Biaxial positioning frame with horizontal. Vertical movement.
C	Control Panel
D	Hydraulic Powerpack
E	Remote Control
F	Electrical Cabinet

Features :

- Used for insertion of long & heavy tube bundle inside shell of heat exchanger.
- Insert tube bundle at rate of 3mtrs/min.
- Generates a coaxial force of 60 tons to insert tube bundle into the shell without jolts thereby avoiding damages to shell & bundles.
- Can be easily converted into double headed tube puller for tube extraction.

TECHNICAL SPECIFICATIONS

Model	Pulling Force	Insertion Speed	Maximum Pressure	Power	Volts/phase	Tank Capacity	Weight
	Tons					Liter	
TBI	60	3	300	8	380-50Hz/3	150	800



# TUBE REMOVAL TOOLS

Page 45-60



$\frac{3}{8}$ " -  $\frac{1}{4}$ "  
O.D.

## AIR / HYDRAULIC STUB PULLER

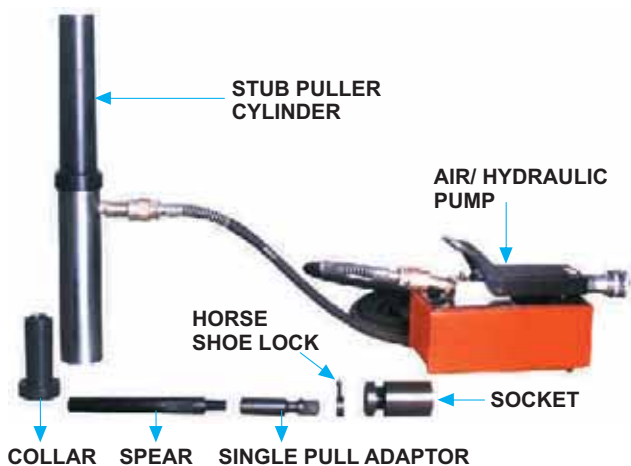

### Features :

- Improved productivity and better operator control through foot pedal.
- Extremely compact, durable, lightweight and portable package-useful in confined areas.
- Makes pulling tubes faster and easier.
- Quick and easy arrangement to reduce downtime.
- Safe. Totally air operated for use in explosive environments.

**Air-Powered Hydraulic Stub Puller set consists of :**  
Self Tapping Spear . Air Powered hydraulic Pump with FRL unit.  
Stub Puller cylinder assembly (supplied in 2 models). Carrying case.

### AIR / HYDRAULIC PUMP - MODEL NO. ASP-1008

Length (mm)	264
Width (mm)	135
Height (mm)	205
Weight without oil (kg)	6.6
Hose Length (ft.)	6
Hose I.D. (Inch)	1/4"
Air inlet Port	1/2" BSP
Hydraulic Port	3/8" NPT
Hydraulic Oil	VG ISO 68 Grade
Working Air pressure (bar)	7
Working hydraulic pressure (bar)	700

### STUB PULLER CYLINDER

Model	AHSP-4	AHSP-9
Extraction Load (Ton)	4	9
Recommended Tube Sizes	Up to 3/4" OD	Up to 1.1/4" OD
Overall Dimension (mm) L x Ø	550 x Ø65.0	550 x Ø104.0
Stroke (mm)	150	150
Pulling Speed Secs. / Stroke	15	30
Weight (kg) with accessories	9	18.5



### SPRING BALANCER

Model	Balancing Capacity	Suitable For
SWF-9	5 - 9 kgs	AHSP-4
SWF-22	15 - 22 kgs	AHSP-9

### SELECTION CHART FOR SPARES

Spares	Spare Code	Suitable For
Filter Regulator Lubricator (FRL)	ASP-1001	AHSP-4/AHSP-9
QRC for air inlet	ASP-1006	
QRC WP-700 bar (male)	ASP-1010	
Hydraulic hose	ASP-1011	
QRC WP-700 bar (female)	ASP-1012	
Support Collar -1	ASP-1014a ASP-1014b	
Spear Lock Adapter	ASP-1015a	AHSP-4
	ASP-1015b	AHSP-9
Horse Shoe Lock	ASP-1016a	AHSP-4
	ASP-1016b	AHSP-9
Single Pull Adapter	ASP-1017a	AHSP-4
	ASP-1017b	AHSP-9



### PULLING SPEARS

Model	Tube O.D. inch	Tube thk. bwg	Model	Tube O.D. inch	Tube thk. bwg
SS-0916	3/8	16-17	SS-2212	7/8	12-13
SS-0918	3/8	18-19	SS-2214	7/8	14-15
SS-0920	3/8	20-21	SS-2216	7/8	16-17
SS-0922	3/8	22-23	SS-2218	7/8	18-19
SS-1214	1/2	14-15	SS-2220	7/8	20-21
SS-1216	1/2	16-17	SS-2509	1	9-10
SS-1218	1/2	18-19	SS-2510	1	10-11
SS-1220	1/2	20-21	SS-2512	1	12-13
SS-1222	1/2	22-23	SS-2514	1	14-15
SS-1512	5/8	12-13	SS-2516	1	16-17
SS-1514	5/8	14-15	SS-2518	1	18-19
SS-1518	5/8	18-19	SS-2520	1	20-21
SS-1520	5/8	20-21	SS-3112	1.1/4	12-13
SS-1911	3/4	11-12	SS-3114	1.1/4	14-15
SS-1912	3/4	12-13	SS-3116	1.1/4	16-17
SS-1914	3/4	14-15	SS-3118	1.1/4	18-19
SS-1916	3/4	16-17	SS-3120	1.1/4	20-21
SS-1918	3/4	18-19			
SS-1920	3/4	20-21			

**NOTE :** • Pulling Spears, Single and Double Pull Adaptors, Horse Shoe Locks and Extensions are compatible for use with 'Pine Jenny' type tube pullers.  
• For larger size tube pulling spears, please enquire.



# CONTINUOUS HYDRAULIC TUBE PULLER

3/8" - 4"  
O.D.



## Features :

- Pulling gun communicates with electric powerpack via 9v DC control. This ensures safety and eliminates the need of electrical cord between pump and gun that other manufacturers provide. In pneumatic version communication is via pneumatic control.
- Available with a choice of Electric-TPP System or Pneumatic-PPP System for hazardous, explosive working environments.
- Microprocessor controls on powerpack and gun ensure trouble free life.
- Removes tube without any damage to tube sheet.
- Low setup time and ease of operation.
- High power & High speed automatic cycling, for highest speed of pull available worldwide.
- Auto switchover from low pressure high flow to high pressure low flow on load and again back to low pressure high flow when load is released.
- Automatic slow start feature to minimize risk of breaking tubes and to conserve consumables.
- Compact design of Powerpack and Gun.
- Interchangeable pulling guns with same Powerpack. 15 ton gun for light duty high speed work, 30 ton gun for heavy duty tube pulling and 45 ton gun for tubes upto 3" O.D.
- Pulls up to 3" OD tubes continuously, pulls up to 4" O.D. stub.
- Low maintenance cost and worldwide availability of components.
- Significant saving of time and money over conventional systems.
- Unit is portable with handle and mounted on four wheels for easy handling.
- Unit will pull tubes continuously through the gun effortlessly, needing only one man for operation.

## SEQUENCE OF OPERATION

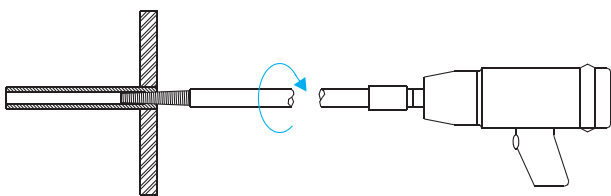

**A) Thread mandrel into tube with Impact Wrench**

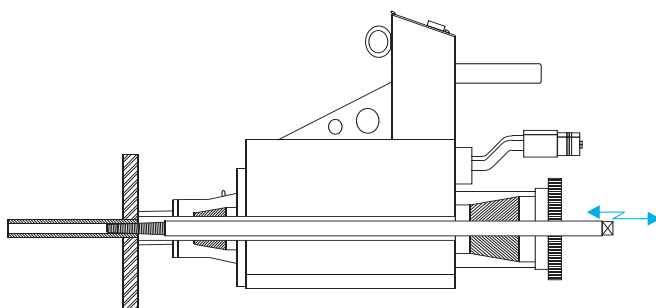
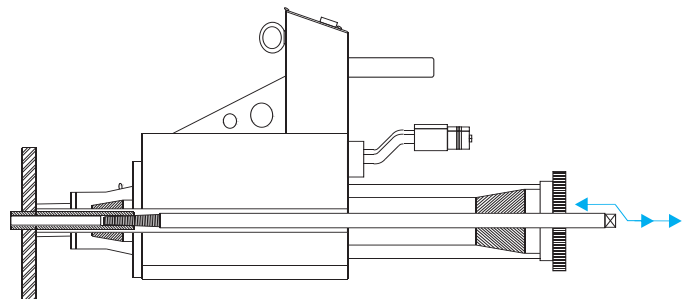

**B) Mount Pulling Gun onto mandrel.**  
Automatic Slow Start to first break expanded joint.

**C) Switch to Auto Cycle by pressing 'AUTO' button** till tube is completely removed. Gun will continue to cycle till one of the other buttons is pressed. When the tube is free, a tool can be inserted into the jaws to enable the tube to be pulled by hand.

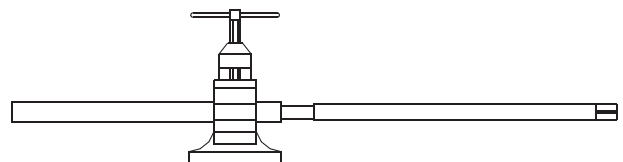

**D) Unscrew mandrel from pulled tube and proceed to next tube.**

3/8"-4"  
O.D.

**CONTINUOUS HYDRAULIC TUBE PULLER**



**TPP-50 (Electric) Pump**



**PPP-50 (Pneumatic) Pump**

**TUBE PULLING POWERPACK - SPECIFICATIONS**



Model	Motor	Volts/Phase	Power hp	Oil Tank Capacity ltrs.	Net Wt. kgs.	Dim. mm	Air Supply	Hyd.Hoses Size x Length inch x mtrs.
TPP-50	Siemens	415 / 3	5	90	220	1200 x 750 x 990	-	1/2"x5 & 3/4"x5
TPP-30	Siemens	230 / 1	3	12	42	500 x 410 x 750	-	1/2"x5 & 3/4"x5
PPP-50 (Pneumatic)	Gast	-	9	90	220	1200 x 750 x 990	180CFM AT 7 BAR	1/2"x5 & 3/4"x5

**Note :** Max. Working Pressure 350 Bar  
ALL Powerpacks supplied with 5 mtr. long hydraulic hoses.

**HYDRAULIC TUBE PULLING GUNS (ELECTRIC) - SPECIFICATIONS**



Gun Model	Pulling Capacity tons	Max. Tube O.D. Thru Gun inch	Stub Pulling Capacity inch	Weight		Free Pulling Speed (meter/min) with		
				kgs.	lbs.	TPP-50	TPP-30	PPP-50
HPG-15	15	1	1.1/2	26	57	5.2	1.8	5.6
HPG-30	30	1.1/2	3	38	84	3.0	2.4	3.5
HPG-45	45	3	4	78	172	2.0	2.0	2.3



**HYDRAULIC TUBE PULLING GUNS (PNEUMATIC) - SPECIFICATIONS**



Gun Model	Pulling Capacity tons	Max. Tube O.D. Thru Gun inch	Stub Pulling Capacity inch	Weight		Free Pulling Speed (meter/min) with		
				kgs.	lbs.	TPP-50	TPP-30	PPP-50
AHPG-15	15	1	1.1/2	26	57	5.2	1.8	5.6
AHPG-30	30	1.1/2	3	38	84	3.0	2.4	3.5
AHPG-45	45	3	4	78	172	2.0	2.0	2.3

**Note :** All pulling guns are supplied with Forward, Reverse, and Auto Cycle Switches.

# ACCESSORIES FOR CONTINUOUS TUBE PULLER

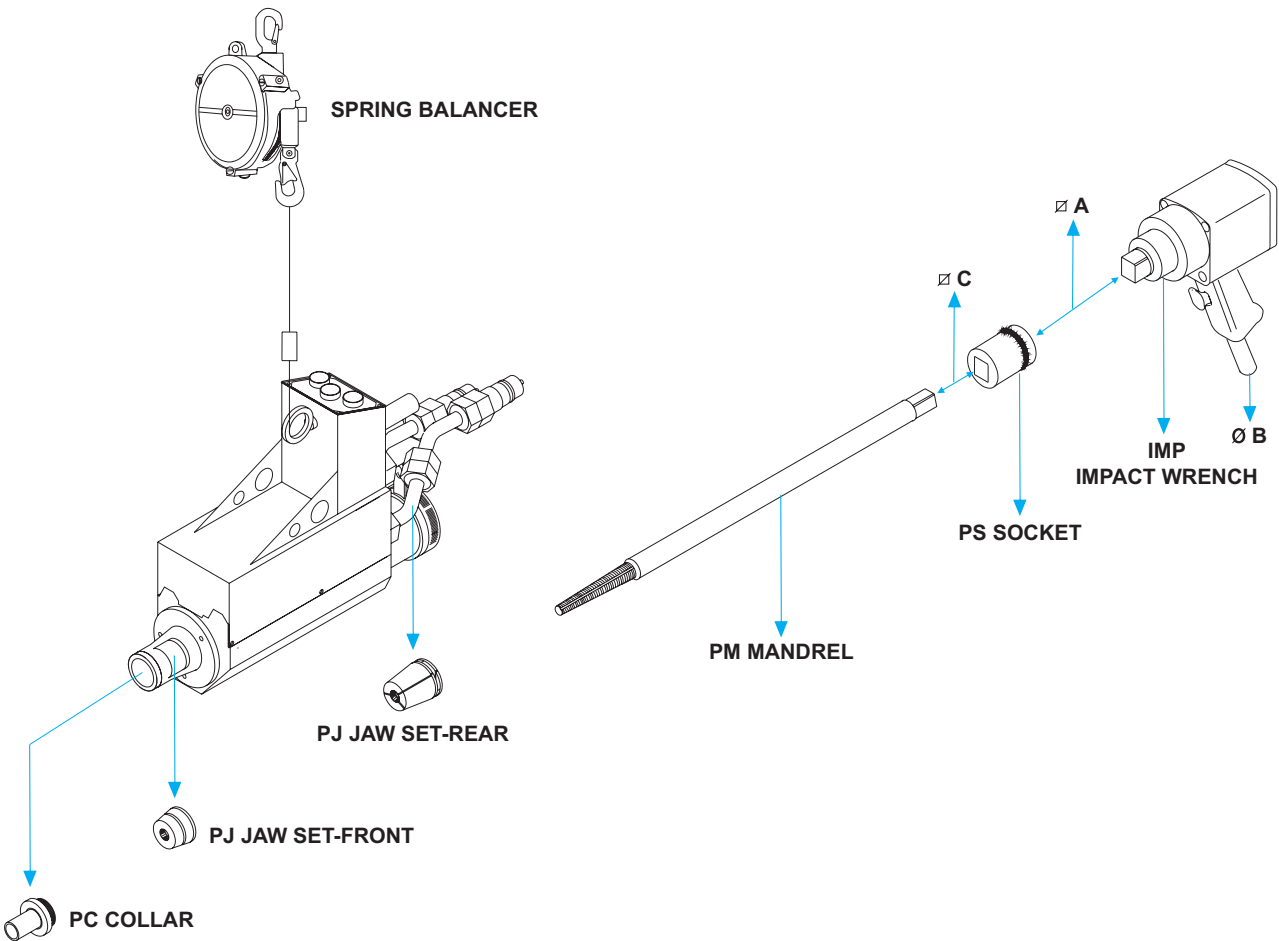

## SPRING BALANCER

- Used to suspend pulling guns for 'feather touch', operation.
- Frees the operator from handling weight of the gun, allowing him to concentrate on the tube pulling operation.

Model	Balancer Range		For Pulling Gun Model	Weight	
	kg	lbs		kgs.	lbs.
SWF-30	20 - 30	44 - 66	HPG-15 / AHPG-15	9.5	21.0
SWF-40	30 - 40	66 - 88	HPG-30 / AHPG-30	10.5	23.1
SWF-85	70 - 85	154 - 187	HPG-45 / AHPG-45	15.0	33.0

## IMP - IMPACT WRENCH

- Used to thread PM mandrels into tube with help of sockets.

Model	Suited For Mandrel Model Numbers	Weight		Ø A	Ø B
		kg	lbs		
IMP-1	PM-7 to PM-37	5.0	11.0	3/4"	3/8"
IMP-2	PM-19 to PM-95/102	10.5	23.0	1"	1/2"

## PS - SOCKET

- Used to connect impact wrench to pulling mandrel.

Model	Ø A	Ø C
PS-1	3/4"	3/8"
PS-2	3/4"	1/2"
PS-3	3/4"	5/8"
PS-4	3/4"	3/4"
PS-5	3/4"	1"
PS-6	1"	3/4"
PS-7	1"	1"
PS-8	1"	1.1/2"

# WORKING CONSUMABLES - CONTINUOUS TUBE PULLER

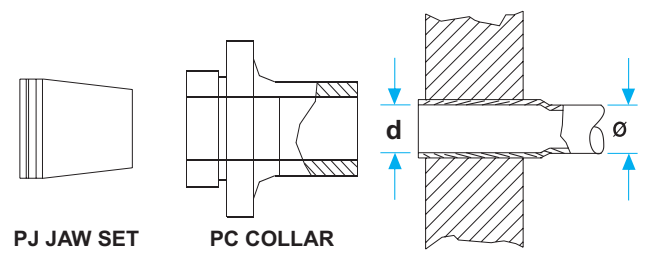
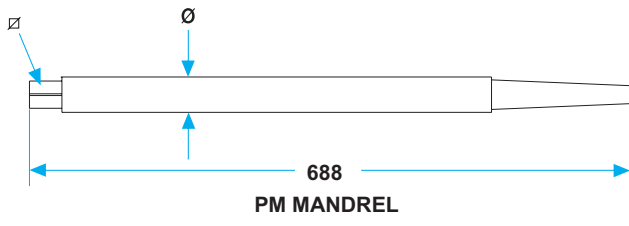

Tube Size		Tube I.D. after Expansion d		Mandrel		Jaw Set			Collar		
				Model	Square Size	Model For HPG-15	Model For HPG-30	Model For HPG-45	Model For HPG-15	Model For HPG-30	Model For HPG-45
Ø	bwg	mm	inch	PM	∅	PJ 15	PJ 30	PJ 45	PC 15	PC 30	PC 45
3/8"	17-19	6.5-7.5	0.260-0.295	7	5/16"	1	1		11	11	
	20-24	7.5-8.5	0.295-0.335	8							
1/2"	14-16	8.5-9.5	0.335-0.375	9	3/8"	2	2		15	15	
	17-18	9.5-10.5	0.375-0.415	10							
	19-21	10.5-11.5	0.415-.0.455	11							
	24	11.5-12.5	0.455-0.495	12							
5/8"	16-17	12.5-13.5	0.495-0.535	13 A	1/2"	3	3		18	18	
	19-21	13.5-14.5	0.535-0.570	14 A							
	23-24	14.5-15.5	0.570-0.610	15 A							
3/4"	11	12.5-13.5	0.495-0.535	13	5/8"	4	4		21	21	
	12-13	13.5-14.5	0.535-0.570	14							
	14-15	14.5-15.5	0.570-0.610	15							
	16-17	15.5-16.5	0.610-0.650	16							
	18-20	16.5-17.5	0.650-0.690	17							
	21-24	17.5-18.5	0.690-0.730	18							
7/8"	14	17.5-18.5	0.690-0.730	18 S	5/8"	4/A	4/A		25	25	
	16-17	18.5-19.5	0.730-0.770	19 S							
	18-19	19.5-20.5	0.770-0.810	20 S							
1"	10-11	18.5-19.5	0.730-0.770	19	3/4"	5	5	5	28	28	28
	12	19.5-20.5	0.770-0.810	20							
	13-14	20.5-21.5	0.810-0.845	21							
	15-16	21.5-22.5	0.845-0.885	22							
	18	22.5-23.5	0.885-0.925	23							
	19-20	23.5-24.5	0.925-0.965	24							
3/4" Gas	13	21.5-22.5	0.845-0.886	22 G			6	6		31	31
	14-15	22.5-23.5	0.886-0.925	23 G							
	16-17	23.5-24.5	0.925-0.965	24 G							
	19-21	24.5-25.5	0.965-1.005	25 G							
	10	24.5-25.5	0.965-1.005	25							
1.1/4"	11-12	25.5-26.5	1.005-1.045	26	1"	7	7		34	34	
	13	26.5-27.5	1.045-1.085	27							
	14-15	27.5-28.5	1.085-1.125	28							
	16-18	28.5-29.5	1.125-1.160	29							
	19-22	29.5-30.5	1.160-1.200	30							
	23-24	30.5-31.5	1.200-1.240	31							
1" Gas	9	25.5-26.5	1.005-1.045	26 G		8	8		37	37	
	10	26.5-27.5	1.045-1.085	27 G							
	11-12	27.5-28.5	1.085-1.125	28 G							
	13-14	28.5-29.5	1.125-1.160	29 G							
	10-11	31.5-32.5	1.240-1.280	32							
1.1/2"	12-13	32.5-33.5	1.280-1.320	33		9	9		41	41	
	14	33.5-34.5	1.320-1.360	34							
	15-17	34.5-35.5	1.360-1.400	35							
	18-20	35.5-36.5	1.400-1.440	36							
	21-24	36.5-37.5	1.440-1.475	37							

**Note :** All models indicated above are for continuous tube pulling. When you are using equipment for stub pulling, please contact us for modifications needed.

# WORKING CONSUMABLES - CONTINUOUS TUBE PULLER

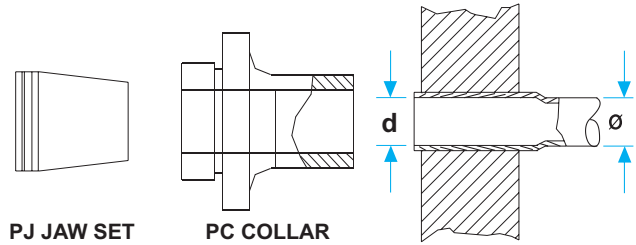
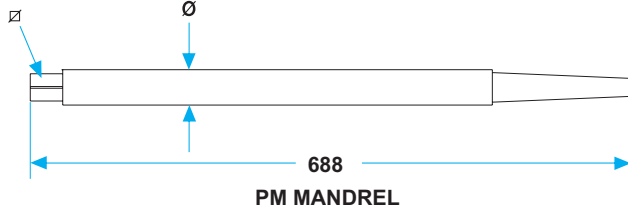

Tube Size		Tube I.D. after Expansion D		Mandrel		Jaw Set			Collar		
OD / Ø	bwg	mm	inch	Model	Square Size	Model For HPG-15	Model For HPG-30	Model For HPG-45	Model For HPG-15	Model For HPG-30	Model For HPG-45
				PM	∅	PJ 15	PJ 30	PJ 45	PC 15	PC 30	PC 45
1.1/4" Gas	12	36.5-37.5	1.440-1.475	37G	1"			10		44	44
	13-14	37.5-38.5	1.475-1.515	38G							
	15-16	38.5-39.5	1.515-1.555	39G							
	17-19	39.5-40.5	1.555-1.595	40G							
	20-24	40.5-41.5	1.595-1.635	41G							
1.3/4"	10-11	37.5-38.5	1.475-1.515	38/44							
	12	38.5-39.5	1.515-1.555	39/44							
	13-14	39.5-40.5	1.555-1.595	40/44							
	15-16	40.5-41.5	1.595-1.635	41/44							
	18-19	41.5-42.5	1.635-1.675	42/44							
1.1/2" Gas	20-24	42.5-43.5	1.675-1.715	43/44							
	11-12	42.5-43.5	1.715-1.755	43G							
	13-14	43.5-44.5	1.755-1.795	44G							
	15-17	44.5-54.5	1.795-1.830	45G							
2"	18-19	45.5-46.5	1.830-1.870	46G							
	10	43.5-44.5	1.830-1.870	44/51							
	11-12	44.5-45.5	1.870-1.910	45/51							
	13	45.5-46.5	1.910-1.950	46/51							
	14-15	46.5-47.5	1.950-1.990	47/51							
	16-18	47.5-48.5	1.870-1.910	48/51							
2.1/4"	19-22	48.5-49.5	1.910-1.950	49/51							
	9-10	49.5-50.5	1.950-1.990	50/57							
	11	50.5-51.5	1.990-2.030	51/57							
2" Gas	12-13	51.5-52.5	2.030-2.070	52/57							
	7	50.5-51.5	1.990-2.030	51G							
	8	51.5-52.5	2.030-2.070	52G							
2.1/2"	9	53.5-53.5	2.070-2.105	53G							
	7	53.5-54.5	2.015-2.145	54/63							
	8	54.5-55.5	2.145-2.185	55/63							
	9	55.5-56.5	2.185-2.225	56/63							
3"	10	56.5-57.5	2.225-2.265	57/63							
	7	66.5-67.5	2.580-2.620	67/76							
	8	67.5-68.5	2.620-2.660	68/76							
	9-10	68.5-69.5	2.660-2.695	69/76							
	11	69.5-70.5	2.695-2.735	70/76							

**Note :** For Tubes larger than 3" O.D., please contact us for larger size working consumables and larger size tube pulling guns.  
All models indicated above are for continuous tube pulling. When you are using equipment for stub pulling, please contact us for modifications needed.



# AUTO STUB PULLER

### Features :

- Designed for fast removal of ferrous and non-ferrous tubes from Condensers, Heat Exchangers, and Boilers.
- A rapid stroke allows the removal of 10 tubes a minute with little operator efforts.
- Gripping and pulling done in single operation.
- Compact and lightweight pulling gun, easy to operate inside boiler drum with 24 Volt DC control.
- Auto ejection of tube after removal.
- Remove tubes without any damage to tube sheet.
- Pneumatic version available for hazardous and explosive areas.
- Low setup time and ease of operation.
- Auto Switchover from low-pressure high flow to high-pressure low flow on load and back again when load is released.
- Interchangeable pulling gun with same power pack.
- Significant savings of time & money over conventional methods of stub removal.
- Can pull from 13 mm to 51 mm I.D. tubes.

### OPERATION

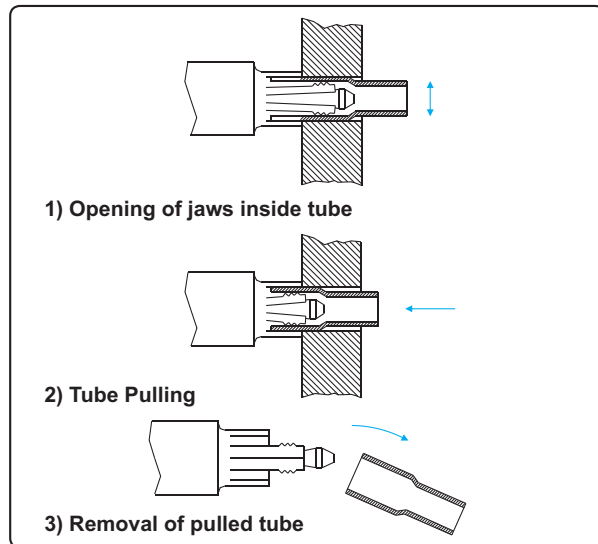

### AUTO STUB PULLER SET

Model	Tube Size ID		Stub Pulling Gun Model	Hydraulic Powerpack Model	Spring Balancer Model To Suspend Gun
	mm	inch			
ASP-1	13 - 31	1/2 - 1.1/4	CTP - 900	PPP-35 / EPP - 15	SWF - 22
ASP-2	31 - 51	1.1/4 - 2	CTP - 1100	PPP-35 / EPP - 15	SWF - 40

### STUB PULLING GUN - SPECIFICATIONS

Model Number	CTP-900	CTP-1100
Capacity / inside dia. of expanded tube (mm)	13 to 31	31 to 51
Maximum stroke (mm)	75	120
Weight (kg)	21	39
Max. Working Pressure (bar)	700	700
Max. Pulling force (ton)	13	31



### HYDRAULIC POWERPACK - SPECIFICATIONS

Model Number	PPP-35	EPP-15
Power	Pneumatic	Electric
Motor H.P	3.5	1.5
Flow rate	4.5 lpm at 0 - 70 bar 1.8 lpm at 70 - 700 bar	3.5 lpm at 0 - 70 bar 0.45 lpm at 70 - 700 bar
Tank capacity (liters)	10	10
Weight including oil (kg)	40	52



**Note :** 5 mtr. long Remote Control and 5 mtr. long Hose set are supplied with Powerpack.

# WORKING CONSUMABLES FOR AUTO STUB PULLER

Part Number	Description
1	Stub Pulling Gun
2	Control Box
3	Tie Rod
4	Compression Spring
5	Guide Washer
6	Jaws
7	Rubber Sleeve
8	Washer
9	Sleeve
10	Support Collar
11	Lock Nut
12	Pulling Collar
13	Spring Balancer

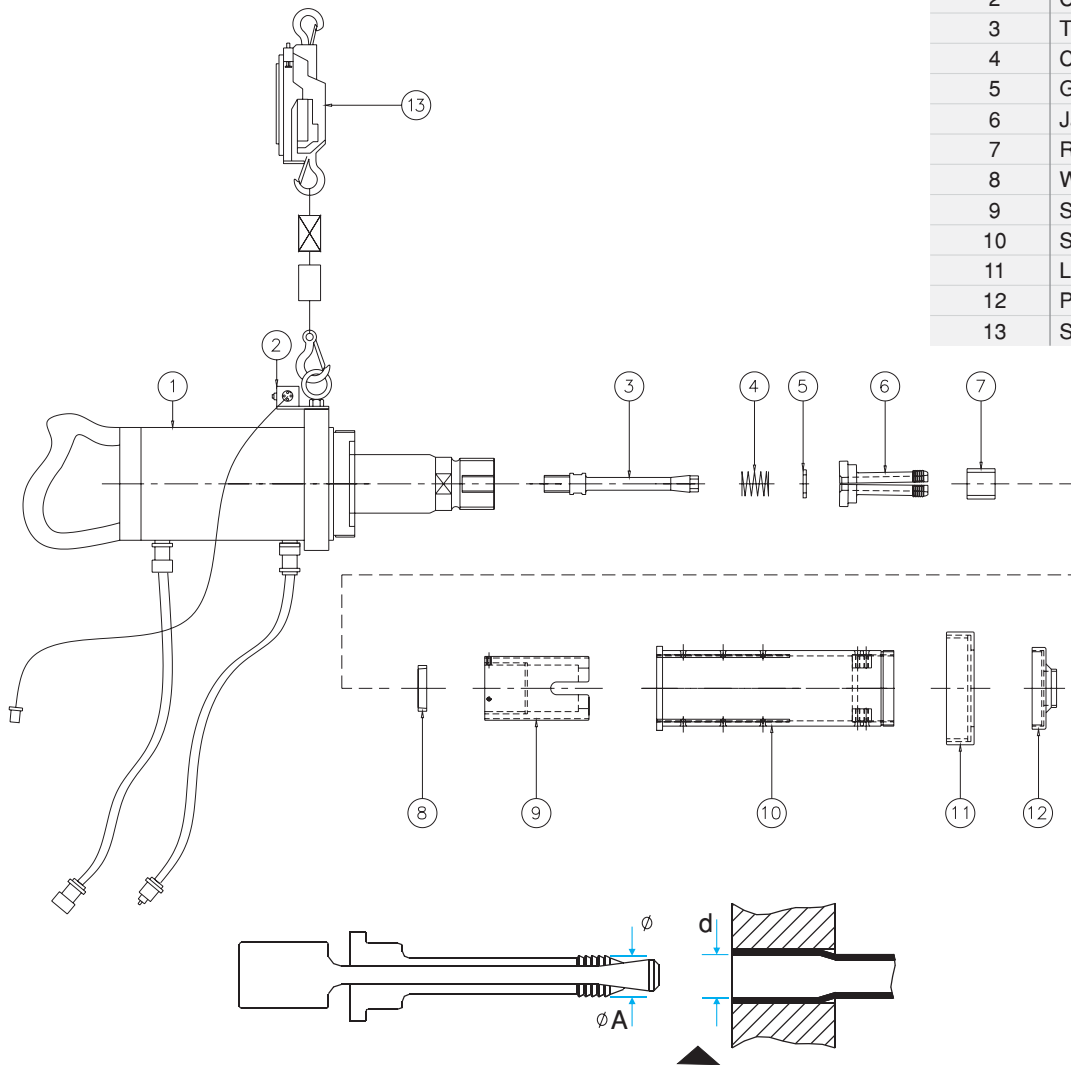

$$\phi A = \phi d - (0.5 \text{ to } 1 \text{ mm})$$

$\phi A$  : diameter of jaws

$\phi d$  : Inside diameter of expanded tube

## JAWS FOR CTP-900





$\phi A$		Model
mm	inch	
12	.472	960/120
13	.512	960/130
14	.551	960/140
15	.591	960/150
16	.630	960/160
17	.669	960/170
18	.709	960/180
19	.748	960/190
20	.787	960/200
21	.827	960/210
22	.866	960/220
23	.906	960/230
24	.945	960/240
25	.984	960/250
26	1.024	960/260
27	1.063	960/270
28	1.102	960/280
29	1.142	960/290
30	1.181	960/300

## JAWS FOR CTP-1100

$\phi A$		Model
mm	inch	
31	1.220	1160/310
32	1.260	1160/320
33	1.299	1160/330
34	1.339	1160/340
35	1.378	1160/350
36	1.417	1160/360
37	1.457	1160/370
38	1.496	1160/380
39	1.535	1160/390
40	1.575	1160/400
41	1.614	1160/410
42	1.654	1160/420
43	1.693	1160/430
44	1.732	1160/440
45	1.772	1160/450
46	1.811	1160/460
47	1.850	1160/470
48	1.890	1160/480
49	1.929	1160/490
50	1.969	1160/500

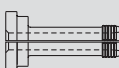
## WORKING CONSUMABLES FOR AUTO STUB PULLER

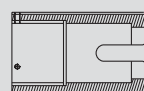
### JAWS - TIE ROD - SUPPORT COLLAR - SLEEVE - PULLING COLLAR FOR CTP TUBE PULLER

						
Gun Model	Jaws Model	Tie Rod Model	Support Collar	Sleeve Model	Pulling Collar Model	Spring Balancer
CTP-900	960/120 to 960/140	970/55	SC-980	S-990	PC-950 Refer chart below	SWF-22
	960/150 to 960/180	970/60				
	960/190 to 960/200	970/80				
	960/210 to 960/240	970/120				
	960/250 to 960/300	970/160				
CTP-1100	1160/310 to 1160/350	1170/220	SC-1180	S-1190	PC-1150 Refer chart below	SWF-40
	1160/360 to 1160/400	1170/270				
	1160/410 to 1160/450	1170/320				
	1160/460 to 1160/500	1170/370				

### COLLARS FOR CTP TUBE PULLERS

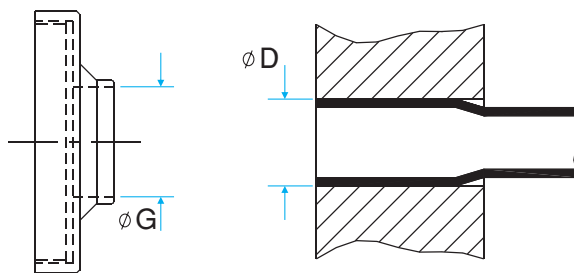

$$\phi G = \phi D + 3 \text{ mm}$$

$\phi A$  : inside diameter of collar

$\phi D$  : outside diameter of tube to be pulled

#### FOR CTP - 900

##### PULLING COLLAR PC-950

OD OF TUBE		INSIDE DIA. OF COLLAR		Model
mm	inch	mm	inch	
15.87	5/8"	19.0	0.748	PC-950/190
19.05	3/4"	22.0	0.866	PC-950/220
22.22	7/8"	25.0	0.984	PC-950/250
25.40	1"	29.0	1.142	PC-950/290
25.40	1.1/8"	32.0	1.260	PC-950/320
31.75	1.1/4"	35.0	1.378	PC-950/350
34.92	1.3/8"	38.0	1.496	PC-950/370

#### FOR CTP - 1100

##### PULLING COLLAR PC-1150

OD OF TUBE		INSIDE DIA. OF COLLAR		Model
mm	inch	mm	inch	
38.10	1.1/2"	41.0	1.614"	PC-1150/410
41.27	1.5/8"	44.0	1.732"	PC-1150/440
44.45	1.3/4"	48.0	1.890"	PC-1150/480
47.62	1.7/8"	51.0	2.001"	PC-1150/510
50.80	2"	54.0	2.126"	PC-1150/540
53.97	2.1/8"	57.0	2.244"	PC-1150/570



# TUBE REMOVAL TOOLS

3/8"-4"  
O.D.



## TUBE WALL REDUCER

### Features :

- Used to 'thin' the walls of heavy gauge tubes as a step in their removal from tube sheet.
- Suffix model number with tube gauge when ordering. Example for 3/4" O.D. 16G, model number will be WR-750-16.
- Wall reducers available for mm tube sizes also. Please enquire.
- Wall reducers are suited for tube sheets up to 5" thick. Longer reaches are available.



## TUBE DRIFT/KNOCKOUT TOOL

### Features :

- Used with pneumatic chipping hammer to knock out tubes / tube stubs from tube sheet.
- Available in 01 and 06 shanks as standard. 15 (Jumbo) shank available on request.
- Suffix model number with tube gauge and shank when ordering. Example for 3/4" O.D. 16G, 06 shank, model number will be KT-750-16-06.
- Tube Drifts are available for mm tube sizes also. Please enquire.
- Standard reach is 6". Longer reaches are available.



## COLLAPSING TOOL

### Features :

- Used to collapse tube and drive out collapsed tube from tube sheet with a chipping hammer.
- Recommended for use on 16G and thinner tubes.
- Available on 01 and 06 shanks as standard.
- Suffix model number with shank number when ordering. Example for 3/4" O.D. 16G, 06 shank, model number will be CT-750-06.
- Collapsing tools are available for mm tube sizes and larger tube sizes. Please enquire.

Tube O.D. inch	Model Number	MT Shank #
3/8	WR-375	1
1/2	WR-500	2
5/8	WR-625	2
3/4	WR-750	2
7/8	WR-875	2
1	WR-1000	3
1.1/4	WR-1250	3
1.1/2	WR-1500	3
1.3/4	SH-1750	3
2	SH-2000	3
2.1/2	SH-2500	4
2.3/4	SH-2750	4
3	SH-3000	4
3.1/4	SH-3250	4
3.1/2	SH-3500	4
4	SH-4000	4

Tube O.D. inch	Model Number
3/8	KT-375
1/2	KT-500
5/8	KT-625
3/4	KT-750
7/8	KT-875
1	KT-1000
1.1/4	KT-1250
1.1/2	KT-1500
1.3/4	KT-1750
2	KT-2000
2.1/2	KT-2500
2.3/4	KT-2750
3	KT-3000
3.1/4	KT-3250
3.1/2	KT-3500
4	KT-4000

Tube O.D. inch	Model Number
3/8	CT-375
1/2	CT-500
5/8	CT-625
3/4	CT-750
7/8	CT-875
1	CT-1000
1.1/4	CT-1250
1.1/2	CT-1500
1.3/4	CT-1750
2	CT-2000
2.1/2	CT-2500



Chipping Hammer with safety retainer for use with Tube Drifts / Collapsing Tools.

### MODEL CH-1 - SPECIFICATION

Blows/min	Bore	Stroke	Weight
1600	1.1/8" (28.5mm)	3.1/4" (82.5mm)	16lbs (7.0kg)

$\frac{5}{8}$ " -  $1\frac{1}{2}$ "  
O.D.

## PUSH TYPE INTERNAL TUBE CUTTER - ATP SERIES



- POWERMASTER "Push Type" Internal Tube Cutter quickly cuts through the walls of ferrous tubes in Condensers and Heat Exchangers as a step in their removal from the tube sheet.
- This sturdy "Push Type" Internal Tube Cutter can be used with a portable Electric or Air Drill Motor.
- "Push Type" Cutter is simple to operate. Merely insert it into the tube, apply power, press inward and the tube can be cut in a few seconds. Releasing of inward pressure automatically retracts the Cutter Bit. This Cutter is equipped with an adjustable collar suitable for reaching into tubes at various depths.
- The replaceable cutting bit can be interchanged in a few seconds. Standard adjustable reach is 4"(101.6mm) and they are available in optional increments of 2"(50.8mm). "A" reach = 6"(152.4mm). "B" reach = 8"(203.2mm). "C" reach = 10"(254.0mm) etc. All Tube Cutters come with a complete set of pilots covering the entire range of tube thicknesses for a particular tube O.D. (ATP-625 tube cutters come with a built in pilot suitable for one tube ID only.)
- All Cutters are available for MM tube sizes also. Please enquire.

Tube O.D.	Tube Gauge (BWG)	Tube Cutter Model No. (Std. Reach)	Spare Cutting Bit Model No.
5/8"	14 - 22	ATP-625	ATP-625-SB
3/4"	14 - 22	ATP-750	ATP-750-SB
7/8"	14 - 22	ATP-875	ATP-875-SB
1"	12 - 22	ATP-1000	ATP-1000-SB
1.1/4"	12 - 22	ATP-1250	ATP-1250-SB
1.1/2"	12 - 22	ATP-1500	ATP-1500-SB

**Note :** When ordering Spare Cutting Bits, please specify whether ordering for Non Ferrous, Ferrous or Stainless Tubes. Cutter Bits for these 3 types of tubes are different. Please refer to operation manual for parts list and detailed features.

## INTERNAL TUBE CUTTER - PR68 SERIES

$\frac{1}{2}$ " -  $4\frac{1}{2}$ "  
O.D.



- PR-68 tube cutters are ideal for cutting thick walled boiler tubes of 2" O.D. and higher.
- The Internal Tube Cutter PR-68 is driven via the square in a clockwise direction using either an electric, pneumatic or hydraulic driving machine.
- PR-68 type tube cutters are available in standard reach of 4" (100mm). Additional reaches in increments of 4" are available up to 16" (400mm).

Size	Tool Model Number	Spare Bit Model Number	Tube I.D. Range		Max. Tube O.D.		Body Diameter		Drive Square Male
			mm	inch	mm	inch	mm	inch	
095	0680951	1680951	10 - 12	.394 - .472	15	.591	9.5	.374	1/2"
105	0681051		11 - 13	.433 - .512	18	.709	10.5	.413	
115	0681151	1681151	12 - 14	.472 - .551	19	.748	11.5	.453	
125	0681251	1681251	13 - 15	.519 - .591	20	.787	12.5	.492	
135	0681351		14 - 17	.551 - .669	23	.906	13.5	.531	
155	0681551		16 - 19	.630 - .748	25	.984	15.5	.610	
175	0681751	1681751	18 - 21	.709 - .827	27	1.063	17.5	.689	
195	0681951	1681951	20 - 25	.787 - .984	34	1.339	19.5	.768	
245	0682451	1682451	25 - 30	.984 - 1.181	38	1.496	24.5	.965	
290	0682901	1682901	30 - 35	1.181 - 1.378	43	1.693	29	1.142	
330	0683301		35 - 40	1.378 - 1.575	48	1.890	33	1.299	
380	0683801		40 - 50	1.575 - 1.969	58	2.126	38	1.496	
480	0684801	1684801	50 - 60	1.969 - 2.362	68	2.677	48	1.890	3/4"
530	0685301		55 - 65	2.165 - 2.559	73	2.874	53	2.087	
630	0686301		65 - 75	2.559 - 2.953	83	3.268	63	2.480	
730	0687301	1687301	75 - 85	2.953 - 3.346	93	3.661	73	2.874	
830	0688301		85 - 95	3.346 - 3.740	103	4.055	83	3.268	
930	0689301		95 - 105	3.740 - 4.134	113	4.449	93	3.661	

**Note :** Refer to operation manual for detailed features and parts list.

# ONE REVOLUTION INTERNAL TUBE CUTTER - OTC SERIES

5/8" - 2 1/2"  
O.D.



TOOL BIT

- POWERMASTER "One Revolution" Internal Tube Cutter pierces and cuts off non-ferrous and thin walled ferrous tubes in one revolution.
- This "One Revolution" Internal Tube Cutter is designed for hand operation using a ratchet handle.
- The Cutter Tool Bit operates on an eccentric principle. The Tube Cutter is entered in the tube with the Tool Bit in closed position, ratchet is applied and turned in clockwise direction. The Tool Bit contacts the tube during the One Revolution and pierces the tube wall and as turning is continued the Tool Bit shears through the tube along its circumference. This Cutter is fitted with an adjustable collar enabling it to reach into tubes at various distances and they are available in optional increments of 2"(50.8mm). Standard adjustable reach is 6"(152.4mm). "A" reach = 8"(203.2). "B" reach = 10"(254.0mm). "C" reach = 12"(304.8mm) etc.
- All Cutters are available for MM tube sizes also.

Tube O.D.		Tube Gauge (BWG)	Tube I.D.		Cutter Model No.	Spare Bit Model No.
mm	inch		mm	inch		
15.87	5/8"	14	11.4 - 11.9	.450 - .470	OTC-625-14	OTC-625-SB
		15 - 16	12.0 - 12.9	.472 - .510	OTC-625-16	
		17 - 18	12.7 - 13.5	.500 - .531	OTC-625-18	
		19 - 20	13.5 - 14.2	.531 - .560	OTC-625-20	
		22	14.0 - 14.7	.550 - .580	OTC-625-22	
19.05	3/4	14 - 15	14.7 - 15.5	.580 - .610	OTC-750-14	OTC-750-SB
		16	15.2 - 16.0	.600 - .630	OTC-750-16	
		17 - 18	15.9 - 16.5	.625 - .650	OTC-750-18	
		19 - 20	16.7 - 17.5	.660 - .690	OTC-750-20	
22.22	7/8	14 - 15	17.8 - 18.5	.700 - .730	OTC-875-14	OTC-875-SB
		16 - 17	18.8 - 19.5	.740 - .770	OTC-875-16	
		18	19.3 - 20.0	.760 - .790	OTC-875-18	
		19 - 20	19.8 - 20.6	.780 - .810	OTC-875-20	
25.40	1"	14	20.8 - 21.6	.820 - .850	OTC-1000-14	OTC-1000-SB
		15	21.3 - 22.1	.840 - .870	OTC-1000-15	
		16 - 17	22.8 - 22.6	.860 - .890	OTC-1000-16	
		18 - 20	22.6 - 23.1	.890 - .910	OTC-1000-18	
		22	23.9 - 24.6	.940 - .970	OTC-1000-22	
31.75	1.1/4	12	25.9 - 26.7	1.020 - 1.050	OTC-1250-12	OTC-1250-SB
		13 - 14	26.7 - 27.4	1.050 - 1.080	OTC-1250-14	
		15 - 16	27.9 - 28.7	1.100 - 1.130	OTC-1250-16	
		17 - 19	28.7 - 29.6	1.130 - 1.160	OTC-1250-18	
38.10	1.1/2	12 - 13	32.5 - 33.3	1.280 - 1.310	OTC-1500-12	OTC-1500-SB
		14 - 15	33.8 - 34.5	1.330 - 1.360	OTC-1500-14	
		16 - 17	34.5 - 35.3	1.360 - 1.390	OTC-1500-16	
		18 - 19	35.3 - 36.1	1.390 - 1.420	OTC-1500-18	
50.80	2	12 - 13	45.0 - 46.0	1.770 - 1.810	OTC-2000-12	OTC-2000-SB
		14 - 15	46.2 - 47.2	1.820 - 1.860	OTC-2000-14	
		16 - 17	47.2 - 48.2	1.860 - 1.900	OTC-2000-16	
		18 - 19	48.0 - 49.0	1.890 - 1.930	OTC-2000-18	
63.50	2.1/2	12 - 13	57.6 - 58.6	2.270 - 2.310	OTC-2500-12	OTC-2500-SB
		14 - 15	58.9 - 60.0	2.320 - 2.360	OTC-2500-14	
		16 - 17	60.0 - 61.0	2.360 - 2.400	OTC-2500-16	
		18 - 19	60.7 - 61.7	2.390 - 2.430	OTC-2500-18	

1/4"-1"  
O.D.

**MANUAL TUBE PULLER**



*Features :*

- No power needed: Manual insertion and removal of tube with a hand wrench. Ideal for field service applications.
- Simple Design : Only two major parts reduce inventory.
- Ease of use : Hex at back of spear allows tightening without disassembly of thrust mechanism.
- Range of Sizes : A wide range of sizes allows use on popular tube size. Clarity of markings: Both spear and thrust collar are clearly marked for fast relating tool to job.

Tube Size							Tube Puller Model Number	Spare Spear Model Number
O.D.		BWG	Wall Thickness		I.D.			
mm	inch		mm	inch	mm	inch		
6.35	1/4	18	1.24	.049	3.86	.152	MTP-25-18	MPS-25-18
9.52	3/8	16	1.65	.065	6.22	.245	MTP-38-16	MPS-38-16
9.52	3/8	18	1.24	.049	7.04	.277	MTP-38-18	MPS-38-18
9.52	3/8	20	0.88	.035	7.75	.305	MTP-38-20	MPS-38-20
12.70	1/2	14	2.11	.083	8.48	.334	MTP-50-14	MPS-50-14
12.70	1/2	16	1.65	.065	9.40	.370	MTP-50-16	MPS-50-16
12.70	1/2	18	1.24	.049	10.21	.402	MTP-50-18	MPS-50-18
12.70	1/2	20	0.88	.035	10.92	.430	MTP-50-20	MPS-50-20
15.88	5/8	14	2.10	.083	11.66	.459	MTP-63-14	MPS-63-14
15.88	5/8	16	1.65	.065	12.57	.495	MTP-63-16	MPS-63-16
15.88	5/8	18	1.24	.049	13.39	.527	MTP-63-18	MPS-63-18
15.88	5/8	20	0.88	.035	14.10	.555	MTP-63-20	MPS-63-20
19.05	3/4	14	2.10	.083	14.86	.585	MTP-75-14	MPS-75-14
19.05	3/4	16	1.65	.065	15.75	.620	MTP-75-16	MPS-75-16
19.05	3/4	18	1.24	.049	16.56	.652	MTP-75-18	MPS-75-18
19.05	3/4	20	0.88	.035	17.27	.680	MTP-75-20	MPS-75-20
22.22	7/8	14	2.10	.083	18.01	.709	MTP-87-14	MPS-87-14
22.22	7/8	16	1.65	.065	18.92	.745	MTP-87-16	MPS-87-16
22.22	7/8	18	1.24	.049	19.74	.777	MTP-87-18	MPS-87-18
22.22	7/8	20	0.88	.035	20.45	.805	MTP-87-20	MPS-87-20
25.40	1	14	2.10	.083	21.18	.834	MTP-100-14	MPS-100-14
25.40	1	16	1.65	.065	22.10	.870	MTP-100-16	MPS-100-16
25.40	1	18	1.24	.049	22.91	.902	MTP-100-18	MPS-100-18
25.40	1	20	0.88	.035	23.62	.930	MTP-100-20	MPS-100-20

Note : For larger/other sizes, please enquire.

3/8"-1 1/2"  
O.D.

**TUBE PLUGS**



ONE PIECE



TWO PIECE

- Tube plugs are designed for sealing off leaking or damaged tubes in heat exchangers, condensers, boilers etc. It ensures a uniform joint without damaging the tube sheet.

Tube O.D.		One Piece Tube Plug Model No.	Two Piece Tube Plug Model No.
mm	inch		
9.53	3/8	PLG-375-1	-
12.70	1/2	PLG-500-1	PLG-500-2
15.87	5/8	PLG-625-1	PLG-625-2
19.05	3/4	PLG-750-1	PLG-750-2
22.22	7/8	PLG-875-1	PLG-875-2
25.40	1	PLG-1000-1	PLG-1000-2
31.75	1.1/4	PLG-1250-1	PLG-1250-2
38.10	1.1/2	PLG-1500-1	PLG-1500-2

Note : Tube plugs are available in a variety of materials like carbon steel, brass, stainless steel, fibre etc. Specify material needed when ordering.

# 'PINE JENNY' STYLE TUBE PULLING ACCESSORIES

## 'PINE JENNY' TUBE SPEARS



3/8" - 1" TUBE SPEAR

Model Number	Tube OD inch	BWG
S-0916	3/8	16-17
S-0918	3/8	18-19
S-0920	3/8	20-21
S-0922	3/8	22-24
S-1212	5/8	12-13
S-1214	5/8	14-15
S-1216	5/8	16-17
S-1218	5/8	18-19
S-1220	5/8	20-21
S-1911	3/4	11-13
S-1914	3/4	14-15
S-1916	3/4	16-17
S-1918	3/4	18-19
S-1920	3/4	20-21
S-2212	7/8	12-13
S-2214	7/8	14-15
S-2216	7/8	16-17
S-2218	7/8	18-19
S-2220	7/8	20-21



1.1/4" - 3" TUBE SPEAR

Model Number	Tube OD inch	BWG
S-2509	1	9
S-2510	1	10-11
S-2512	1	12-13
S-2514	1	14-15
S-2516	1	16-17
S-2518	1	18-19
S-2520	1	20-21
S-3112	1-1/4	12-13
S-3114	1-1/4	14-15
S-3116	1-1/4	16-17
S-3318	1-1/4	18-19
S-3120	1-1/4	20-21
S-3814	1-1/2	14-16
S-3817	1-1/2	17-20
S-4414	1-3/4	14-18
S-5014	2	14-18
S-5714	2-1/2	14-18
S-7610	3	10-14

**Note :** For other sizes of 'Pine Jenny' spears. Please enquire.



3055-3 SINGLE PULL ADAPTOR



3055-6 DOUBLE PULL ADAPTOR



3055-5 MALE X MALE EXTENSION



3055-10 MALE X FEMALE EXTENSION



3055-4 HORSE SHOE LOCK



EXTENSION CHAIRS

Model	Tube O.D.
80-3055-7	1.1/4" - 1.1/2"
80-36307	1.3/4"
80-36308	2" - 2.1/4"
80-36309	2.1/2"
80-36310	2.3/4" - 3"

**Note :** All the above items are compatible for use with Tube Pulling Systems of Airetool, Wilson, Elliot and other manufacturers of "Pine Jenny" style systems.

Extension chair is sized to allow tube being pulled to enter I.D. of chair. Spears, Adaptors, Male x Male Extension, Horse Shoe Lock and Extension Chair are needed for sizes 1.1/4" O.D. and larger. Male x Female Extensions are used for longer reach. Consult us for sizes not listed here.

# TUBE BUNDLE EXTRACTORS



Tube Bundle Extractor specifically designed to remove the tube bundle from the tube sheet without damage to shell of heat exchangers.

*Features :*

- 1) Units are designed to be self supporting using either a diesel engine W/ Spark arrestor, or an 18 HP piston type air motor.
- 2) Units can be manufactured with optional remote control so that operator can stand away at safe distance during initial break out of tube bundle.
- 3) Bundle extraction time is 15 - 20 minites depending upon job situation & operators experience.

- Please enquire for more details.

APPROXIMATE WEIGHTS & MEASURES FOR TUBE BUNDLE EXTRACTOR

Model Number	Bundle Length inch	Bundle* Dia. inch	Extractor Dimensions long x wide x high inch	Weight	
				Kgs	Lbs
504	20	66	27-2 x 6-0 x 3-0	6,590.0	14,500
504-S-24	24	66	30-8 x 6-0 x 3-0	7,272.0	16,000
504-S-28	28	66	34-2 x 6-0 x 3-0	7,772.0	17,100
504-S-32	32	66	37-8 x 6-0 x 3-0	10,909.0	24,000

\* Optional bowed tension arms: for bundle tube sheet diameters up to 84" force applied with main cylinder; 113.100 lbs. Standard (189,000 lbs Optional)



# BOILER TUBE EXPANDERS

Page 61-92



# GENERATION II SERIES BOILER TUBE EXPANDERS

## Features :

- Several improvements in the design and manufacture of tube expanders have been pioneered by Powermaster.
- The New Generation II series Boiler Tube Expanders will outlast any other manufacturers expanders! Guaranteed! Please contact us for warranty information.
- Powermaster expanders are competitively priced due to high production volumes and will offer you the best value for money by a long margin!
- Powermaster Generation II series Boiler Tube Expanders is the preferred tool of choice at over 3000 companies worldwide!

CRYOGENIC process - the best treatment ever for tool steels. This is a deep chilling treatment for prolonged period of time, which makes the alloy carbides in steel to precipitate leaving very tough matrix of martensite. Increased toughness guarantees resilience to abnormal shocks, while fine precipitates of carbide reduce wear. Experience suggests 100% increase in life of the tool.

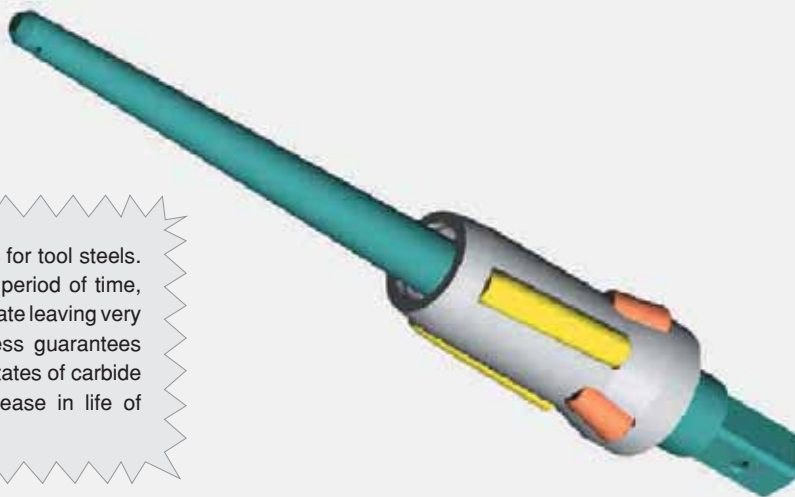

Optimal roll alignment for fast rolling. Maximum roll to tube contact reducing spring back effect. Equal load distribution leading to extended expander life.



CNC machined cages give precision guiding to rolls during expansion. Cages are double tempered for optimum toughness at very high hardness.



One piece constructed mandrel on all models mates with well contoured rolls to give un-bridged smooth expanded tube.

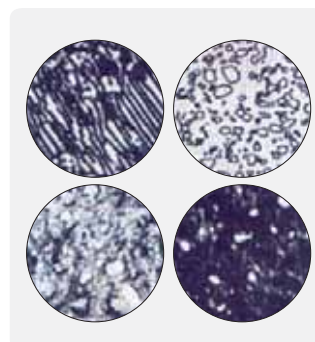

State of the art cryogenic and heat treatment facility guarantees best grain structure in both pre-machined and finished forms.



All components subjected to specific tests. Expander assembly is tested for optimum rolling, expansion and reversing speeds.

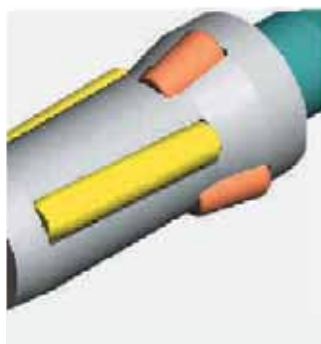

In operation, the initial positioning of the expander in the tube allows the self-feed rolls to draw the expander into the tube and to engage the flaring rolls at proper point during the operation.

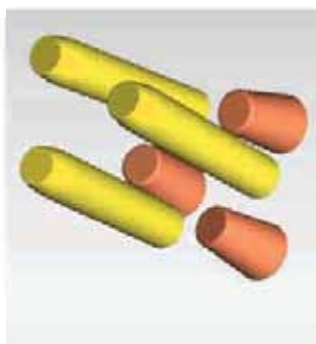

High carbon chromium tool steel for rolls ensures non deformability. Smoother contour and fine ground finishing gives longer life by withstanding operational jerks.

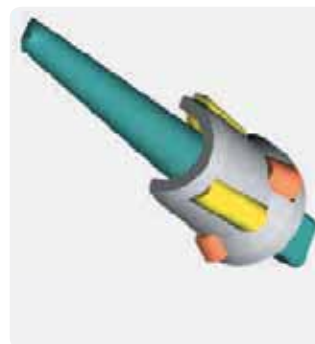

Use of high end solid modeling design and finite element analysis software optimize results and eliminate design & assembly flaws.



# Why **POWERMASTER** Boiler Tube Expanders ?

**Versatility :** POWERMASTER manufactures 12 series of Boiler Tube Expanders. More than any other manufacturer in the world. We have an expander for every conceivable need and every budget.

**Availability :** How often have you heard a manufacturer tell you that they do not have a Boiler Tube Expander on the shelf and quote you a delivery of a few weeks or months. POWERMASTER carries a very large inventory and can service you from stock in most cases.

**Value :** Production volumes ensure that our prices remain competitive. We offer products at a very competitive price.

**Service :** Delivery to your doorstep via courier in 3-4 days - **ANYWHERE IN THE WORLD.**

**Quality :** Large percentages of our revenues are spent on research and development coupled with field testing make POWERMASTER the preferred choice worldwide.

**Certifications :** Powermaster facilities are certified to ISO-9002 by KPMG, USA. Most products manufactured conform to European CE directives.

**History :** You need experience to handle this vast array of products. We have been in the business Since 1971!

**PLEASE MAKE A COPY OF THIS PAGE, FILL UP AND FAX TO US WHEN ORDERING BOILER TUBE EXPANDERS :**

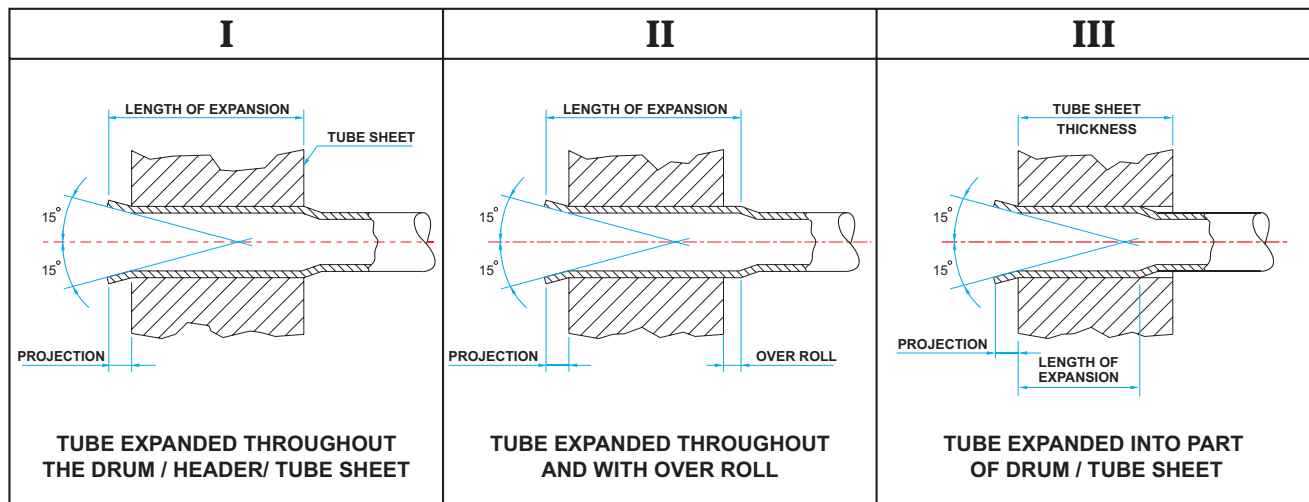

SR No.	DETAILS	1	2	3	4	5	6	7
1.	TUBE OUTSIDE DIAMETER							
2.	TUBE THICKNESS							
3.	TUBE SHEET / DRUM THICKNESS							
4.	LENGTH OF EXPANSION							
5.	TUBE END PROJECTION							
6.	TYPE OF TUBE EXPANDER							
7.	BELL MOUTHING REQUIRED	YES/NO	YES/NO	YES/NO	YES/NO	YES/NO	YES/NO	YES/NO
8.	BEADING REQUIRED	YES/NO	YES/NO	YES/NO	YES/NO	YES/NO	YES/NO	YES/NO

2"-4 1/2"  
O.D.

114 SERIES

- Features :*
- Overlapping rolls prevent ridging of tube.
  - Can be converted for parallel expansion use - enquire with us.
  - Self retained rolls in cage.
  - Compact design for use through small hand holes, headers etc.
  - Use - General purpose expander for expanding and flaring boiler tubes, water wall, downcomer, economizer, riser and air heater tubes.

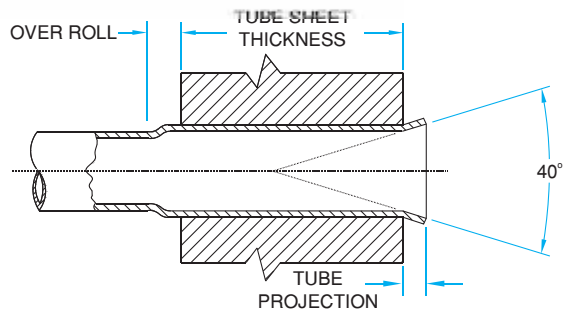

Tube O.D.	Tube Thickness		Tube O.D.	Tube Thickness		Minimum I.D. Tool Enters		Maximum Expansion Of Tool		Tube Expander Model Number Tube Sheet Thickness Range				
	inch	bwg		inch	bwg	inch	mm	inch	mm	inch	1/2" To 7/8"	3/4" To 1.1/8"	1.1/8" To 1.5/8"	1.5/8" To 2.1/8"
2	4 & 5	.238 & .220	1.3/4	11 - 13	.120 - .095	36.7	1.444	43.1	1.696	-	14172	14174	14176	14178
2	6 & 7	.203 & .180	1.3/4	14 - 16	.480 - .065	38.3	1.507	44.6	1.755	-	14182	14184	14186	14188
2	7 & 8	.180 & .165				39.9	1.570	46.4	1.826	14191	14192	14194	14196	14198
2	9 & 10	.148 & .134	2.1/4	13	.095	41.5	1.633	48.0	1.889	14201	14202	14204	14206	14208
2	11 - 13	.120 - .095	2.1/4	4 & 5	.238 & .220	43.1	1.696	49.6	1.952	14211	14212	14214	14216	14218
2.1/2	2	.284	2.1/4	6 - 8	.203 - .165	45.5	1.791	52.6	2.070	-	14222	14224	14226	14228
2.1/2	3 & 4	.259 & .238	2.1/4	9 - 11	.148 - .120	47.1	1.856	54.2	2.133	-	14232	14234	14236	14238
2.1/2	4 - 6	.238 - .203	2.1/4	12 - 15	.109 - .072	49.0	1.929	57.3	2.255	-	14242	14244	14246	14248
2.1/2	7 - 10	.180 - .134	2.3/4	2 & 3	.284 & .259	51.9	2.043	60.5	2.381	-	14252	14254	14256	14258
2.1/2	11 - 13	.120 - .095	2.3/4	4 & 5	.238 & .220	55.1	2.169	63.7	2.507	14261	14262	14264	14266	14268
3	1 - 3	.300 - .259	2.3/4	6 - 10	.203 - .134	57.4	2.259	66.6	2.622	-	14272	14274	14276	14278
3	4 - 6	.238 - .203	2.3/4	11 - 15	.120 - .072	60.6	2.385	70.0	2.755	-	14282	14284	14286	14288
3	7 - 11	.180 - .120	3.1/4	1 - 4	.300 - .238	63.8	2.511	73.9	2.909	-	14292	14294	14296	14298
3	10 - 12	.134 - .109	3.1/4	4 - 7	.238 - .180	66.9	2.635	77.3	3.043	14301	14302	14304	14306	14308
3.1/2	1 - 4	.300 - .238	3.1/4	7 - 11	.180 - .120	70.1	2.759	80.1	3.153	-	14312	14314	14316	14318
3.1/2	4 - 7	.238 - .180	3.1/4	10 - 15	.134 - .072	73.0	2.874	83.4	3.283	-	14322	14324	14326	14328
3.1/2	7 - 11	.180 - .120	3.3/4	2 & 3	.284 & .259	76.2	3.000	86.8	3.417	-	14332	14334	14336	14338
3.1/2	10 - 12	.134 - .109	3.3/4	4 & 5	.238 & .220	79.3	3.122	89.8	3.535	-	14342	14344	14346	14348
4	1 - 4	.300 - .238	3.3/4	6 - 10	.203 - .134	82.5	3.248	93.0	3.661	-	14352	14354	14356	14358
4	4 - 7	.238 - .180	3.3/4	11 - 15	.120 - .072	85.7	3.374	96.0	3.779	-	14362	14364	14366	14368
4	7 - 11	.180 - .120	4.1/4	2 & 3	.284 & .259	88.9	3.500	98.6	3.881	-	14372	14374	14376	14378
4	8 - 12	.165 - .109	4.1/4	3 & 5	.259 & .220	90.5	3.562	102.3	4.027	-	14382	14384	14386	14388
4.1/2	1 - 4	.300 - .238	4.1/4	6 - 9	.203 - .148	95.2	3.748	104.7	4.122	-	14392	14394	14396	14398
4.1/2	3 - 8	.238 - .165	4.1/4	10 - 13	.134 - .095	98.4	3.874	110.3	4.342	-	14402	14404	14406	14408
4.1/2	6 - 12	.203 - .109	-	-	-	101.6	4.000	113.5	4.468	-	14412	14414	14416	14418

# 114 SERIES

2" - 4 1/2"  
O.D.

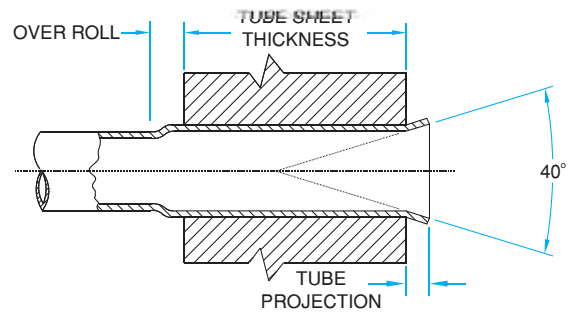

Spare Rollers Set Model Number Tube Sheet Thickness Range					Mandrel Square Drive Size inch	Spare Mandrel Model Number						
1/2" To 7/8"	3/4" To 1.1/8"	1.1/8" To 1.5/8"	1.5/8" To 2.1/8"	2.1/8" To 2.5/8"		Drum Type	Header Type	Short Series 5.1/8 inch				Short Series 7.1/8 inch
-	34872	34874	34878	34948	3/4	32269	32289	32308	32309	32310	32311	34876, 34948
-	34879	34881	34883	34949	3/4	32269	32289	32309	32310	32311	-	-
34878	34879	34881	34883	34949	3/4	32270	32290	32309	32310	32311	32312	-
34878	34879	34881	34883	34949	3/4	32271	32291	32311	32312	32313	-	32346
34885	34886	34888	34890	34950	3/4	32270	32290	32310	32311	32312	-	32345
-	34893	34895	34897	34951	3/4	32270	32290	32310	32311	32312	32313	-
-	34893	34895	34897	34951	3/4	32271	32291	32311	32312	32313	32314	-
-	34893	34895	34897	34951	3/4	32272	32292	32312	32313	21214	32315	32316
-	34900	34902	34904	34952	3/4	32272	32292	32312	32313	32314	32315	32316
34899	34900	34902	34904	34952	3/4	32273	32293	32315	32316	32317	-	32347 32348 32349
-	34907	34909	34911	34953	3/4	32273	32293	32315	32316	32317	32318	32319
-	34907	34909	34911	34953	1	32274	32294	32317	32318	32319	32320	32321
-	34914	34916	34918	34954	1	32274	32294	32318	32319	32320	32321	32322
34913	34914	34916	34918	34954	1	32275	32295	32320	32321	32322	-	33632 33633 33634 33635
-	34921	34923	34925	34955	1	32274	32294	32318	32319	32320	32321	32322
-	34921	34923	34925	34955	1	32275	32295	32321	32322	32323	32324	32325
-	34921	34923	34925	34955	1	32276	32296	32323	32324	32325	32326	32327
-	34921	34923	34925	34955	1	32277	32297	32324	32325	32326	32327	32328
-	34928	34930	34932	34956	1	32276	32296	32324	32325	32326	32327	32328
-	34928	34930	34932	34956	1	32277	32297	32326	32327	32328	32329	32330
-	34928	34930	34932	34956	1	32278	32298	32328	32329	32330	32331	32332
-	34935	34937	34939	34957	1	32277	32297	32324	32325	32326	32327	32328
-	34935	34937	34939	34957	1	32278	32298	32329	32330	32331	32332	32350
-	34935	34937	34939	34957	1	32279	32299	32331	32332	32350	32337	32338
-	34942	34944	34946	34958	1	32278	32298	32326	32327	32328	32329	32330

7/8" - 4 1/2"  
O.D.

**A SERIES**

- Features :*
- Best 'Value for Money' tool in the world when parallel rolling tubes.
  - Sturdy construction with rolls self contained in cage.
  - Time tested, durable design.
  - Use - Economical tool used for applications where tubes are to be expanded without flaring.

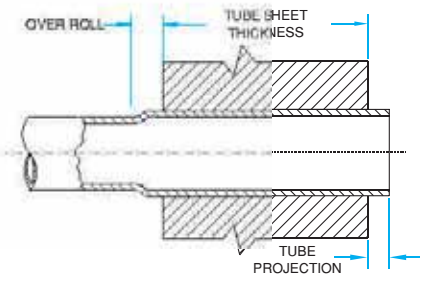

Tube O.D.	Tube Thickness		Tube O.D.	Tube Thickness		Minimum I.D. Tool Enters		Maximum Expansion Of Tool		Tube Expander Model Number Tube Sheet Thickness Range				
	inch	bwg		inch	bwg	inch	mm	inch	mm	inch	1/2" To 7/8"	3/4" To 1.1/8"	1.1/8" To 1.5/8"	1.5/8" To 2.1/8"
7/8	15	.072	1	10	.134	18.1	.712	20.4	.803	A-31/2	A-31/3	-	-	-
7/8	16	.065				18.4	.724	20.7	.814	A-32/2	A-32/3	-	-	-
7/8	17	.058	1	11	.120	18.8	.740	21.1	.830	A-33/2	A-33/3	-	-	-
7/8	18	.049	1	12	.109	19.4	.763	21.6	.850	A-34/2	A-34/3	-	-	-
7/8	19 & 20	.042 & .035	1.1/8	8	.165	19.7	.775	22.3	.877	A-35/2	A-35/3	-	-	-
1	13	.095				20.1	.791	22.4	.881	A-36/2	A-36/3	-	-	-
1	14	.083	1.1/8	9	.148	20.6	.811	23.1	.909	A-37/2	A-37/3	A-37/4	-	-
1	15 & 16	.072 & .065	1.1/8	10	.134	21.3	.838	23.8	.937	A-38/2	A-38/3	A-38/4	-	-
1	17 & 18	.058 & .048	1.1/8	11	.120	22.0	.866	24.5	.964	A-39/2	A-39/3	A-39/4	-	-
1	19 & 20	.042 & .035	1.1/8	12	.109	22.4	.881	25.0	.984	A-40/2	A-40/3	A-40/4	-	-
1.1/4	8	.165	1.1/8	13	.095	23.3	.917	25.9	1.019	A-41/2	A-41/3	A-41/4	-	-
1.1/4	9	.148	1.1/8	14	.083	23.8	.937	26.5	1.043	A-42/2	A-42/3	A-42/4	-	-
1.1/4	10	.134	1.1/8	15 & 16	.072 & .065	24.4	.960	27.2	1.070	A-43/2	A-43/3	A-43/4	-	-
1.1/4	11	.120				25.2	.992	28.0	1.102	A-44/2	A-44/3	A-44/4	-	-
1.1/4	12	.109				25.7	1.011	28.5	1.122	A-45/2	A-45/3	A-45/4	-	-
1.1/4	13	.095	1.3/8	8	.165	26.1	1.027	28.8	1.133	A-46/2	A-46/3	A-46/4	-	-
1.1/4	14	.083				26.4	1.039	29.2	1.149	A-47/2	A-47/3	A-47/4	-	-
1.1/4	15	.072	1.3/8	9	.148	26.9	1.059	29.7	1.169	A-48/2	A-48/3	A-48/4	-	-
1.1/4	16	.065	1.3/8	10	.134	27.6	1.086	30.4	1.196	A-49/2	A-49/3	A-49/4	A-49/5	A-49/6
1.1/2	7	.180	1.3/8	11	.120	28.3	1.114	31.2	1.228	A-50/2	A-50/3	A-50/4	A-50/5	A-50/6
1.1/2	8	.165	1.3/8	12	.109	28.8	1.133	31.7	1.248	A-51/2	A-51/3	A-51/4	A-51/5	A-51/6
1.1/2	9	.148	1.3/8	13 & 14	.095 & .083	29.5	1.161	33.4	1.314	A-52/2	A-52/3	A-52/4	A-52/5	A-52/6
1.1/2	10	.134	1.3/8	15 & 16	.072 & .065	30.0	1.181	34.1	1.342	A-53/2	A-53/3	A-53/4	A-53/5	A-53/6
1.1/2	11 & 12	.120 & .109				30.6	1.204	34.8	1.370	A-54/2	A-54/3	A-54/4	A-54/5	A-54/6
1.1/2	13	.095	1.3/4	5	.220	31.4	1.236	35.6	1.401	A-55/2	A-55/3	A-55/4	A-55/5	A-55/6
1.1/2	14 & 15	.083 & .072	1.3/4	6	.203	32.6	1.283	36.8	1.448	A-56/2	A-56/3	A-56/4	A-56/5	A-56/6
			1.3/4	7	.180	33.4	1.314	38.1	1.500	A-57/2	A-57/3	A-57/4	A-57/5	A-57/6
			1.3/4	8	.165	34.2	1.346	38.7	1.523	A-58/2	A-58/3	A-58/4	A-58/5	A-58/6
2	3	.259	1.3/4	9 & 10	.148 & .134	35.0	1.377	40.6	1.598	A-59/2	A-59/3	A-59/4	A-59/5	A-59/6
2	4	.238	1.3/4	11 & 12	.120 & .109	36.6	1.440	42.2	1.661	A-60/2	A-60/3	A-60/4	A-60/5	A-60/6
2	5 & 6	.220 & .203	1.3/4	13 & 14	.095 & .083	38.2	1.503	43.8	1.712	A-61/2	A-61/3	A-61/4	A-61/5	A-61/6
2	7 & 8	.180 & .165	1.3/4	15 & 16	.072 & .065	39.8	1.566	45.4	1.787	A-62/2	A-62/3	A-62/4	A-62/5	A-62/6
2	9 & 10	.148 & .134	2.1/4	3	.259	41.4	1.629	47.0	1.850	A-63/2	A-63/3	A-63/4	A-63/5	A-63/6
2	11 - 13	.120 - .095	2.1/4	4	.238	42.9	1.688	49.5	1.948	A-64/2	A-64/3	A-64/4	A-64/5	A-64/6
2	14 - 16	.083 - .065	2.1/4	6 & 7	.203 & .180	44.5	1.751	51.1	2.011	A-65/2	A-65/3	A-65/4	A-65/5	A-65/6
2	17 & 18	.058 & .049	2.1/4	8 & 9	.165 & .148	46.1	1.814	52.7	2.074	A-66/2	A-66/3	A-66/4	A-66/5	A-66/6

# A SERIES

7/8" - 4 1/2"  
O.D.

A SERIES

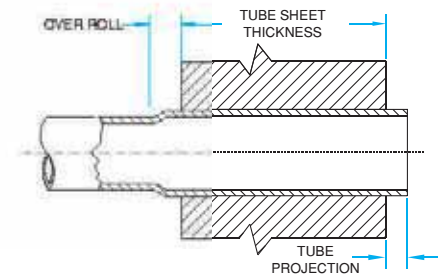

Spare Rollers Set Model Number Tube Sheet Thickness Range					Mandrel Square Drive Size inch	Spare Mandrel Model Number		
1/2" To 7/8"	3/4" To 1 1/8"	1 1/8" To 1 5/8"	1 5/8" To 2 1/8"	2 1/8" To 2 5/8"		Drum Type	Header Type	Short Series Mandrel Set (No. Of Mandrels)
15-2-RS	15-3-RS	-	-	-	3/8	DM-11	-	-
15-2-RS	15-3-RS	-	-	-	3/8	DM-12	-	-
16-2-RS	16-3-RS	-	-	-	3/8	DM-12	-	-
20-2-RS	20-3-RS	-	-	-	3/8	DM-12	-	-
17-2-RS	17-3-RS	-	-	-	3/8	DM-13	-	-
18-2-RS	18-3-RS	-	-	-	3/8	DM-12	-	-
18-2-RS	18-3-RS	18-4-RS	-	-	3/8	DM-13	HM-13	SM-13 (2)
19-2-RS	19-3-RS	19-4-RS	-	-	3/8	DM-13	HM-13	SM-13 (2)
21-2-RS	21-3-RS	21-4-RS	-	-	3/8	DM-13	HM-13	SM-13 (2)
21-2-RS	21-3-RS	21-4-RS	-	-	3/8	DM-14	HM-14	SM-14 (2)
22-2-RS	22-3-RS	22-4-RS	-	-	3/8	DM-14	HM-14	SM-14 (2)
23-2-RS	23-3-RS	23-4-RS	-	-	1/2	DM-15	HM-15	SM-15 (2)
24-2-RS	24-3-RS	24-4-RS	-	-	1/2	DM-15	HM-15	SM-15 (2)
26-2-RS	26-3-RS	26-4-RS	-	-	1/2	DM-16	HM-16	SM-16 (2)
27-2-RS	27-3-RS	27-4-RS	-	-	1/2	DM-16	HM-16	SM-16 (2)
31-2-RS	31-3-RS	31-4-RS	-	-	1/2	DM-16	HM-16	SM-16 (2)
28-2-RS	28-3-RS	28-4-RS	-	-	1/2	DM-17	HM-17	SM-17 (2)
29-2-RS	29-3-RS	29-4-RS	-	-	1/2	DM-17	HM-17	SM-17 (2)
30-2-RS	30-3-RS	30-4-RS	30-5-RS	30-6-RS	1/2	DM-17	HM-17	SM-17 (2)
30-2-RS	30-3-RS	30-4-RS	30-5-RS	30-6-RS	1/2	DM-18	HM-18	SM-18 (2)
32-2-RS	32-3-RS	32-4-RS	32-5-RS	32-6-RS	1/2	DM-18	HM-18	SM-18 (2)
28-2-RS	28-3-RS	28-4-RS	28-5-RS	28-6-RS	1/2	DM-20	HM-20	SM-20 (2)
29-2-RS	29-3-RS	29-4-RS	29-5-RS	29-6-RS	1/2	DM-20	HM-20	SM-20 (2)
30-2-RS	30-3-RS	30-4-RS	30-5-RS	30-6-RS	1/2	DM-20	HM-20	SM-20 (2)
33-2-RS	33-3-RS	33-4-RS	33-5-RS	33-6-RS	1/2	DM-20	HM-20	SM-20 (2)
32-2-RS	32-3-RS	32-4-RS	32-5-RS	32-6-RS	1/2	DM-21	HM-21	SM-21 (2)
36-2-RS	36-3-RS	36-4-RS	36-5-RS	36-6-RS	1/2	DM-21	HM-21	SM-21 (2)
37-2-RS	37-3-RS	37-4-RS	37-5-RS	37-6-RS	1/2	DM-21	HM-21	SM-21 (2)
33-2-RS	33-3-RS	33-4-RS	33-5-RS	33-6-RS	3/4	DM-22	HM-22	SM-22 (3)
37-2-RS	37-3-RS	37-4-RS	37-5-RS	37-6-RS	3/4	DM-22	HM-22	SM-22 (3)
38-2-RS	38-3-RS	38-4-RS	38-5-RS	38-6-RS	3/4	DM-22	HM-22	SM-22 (3)
39-2-RS	39-3-RS	39-4-RS	39-5-RS	39-6-RS	3/4	DM-22	HM-22	SM-22 (3)
40-2-RS	40-3-RS	40-4-RS	40-5-RS	40-6-RS	3/4	DM-22	HM-22	SM-22 (3)
40-2-RS	40-3-RS	40-4-RS	40-5-RS	40-6-RS	3/4	DM-23	HM-23	SM-23 (3)
41-2-RS	41-3-RS	41-4-RS	41-5-RS	41-6-RS	3/4	DM-23	HM-23	SM-23 (3)
42-2-RS	42-3-RS	42-4-RS	42-5-RS	42-6-RS	3/4	DM-23	HM-23	SM-23 (3)



A SERIES

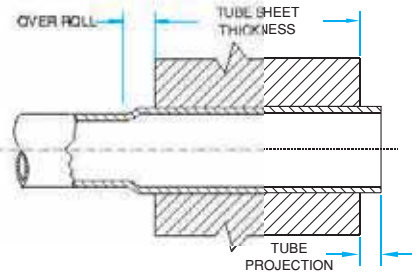

Tube O.D.	Tube Thickness		Tube O.D.	Tube Thickness		Minimum I.D. Tool Enters		Maximum Expansion Of Tool		Tube Expander Model Number Tube Sheet Thickness Range				
	inch	bwg		inch	bwg	inch	mm	inch	mm	inch	1/2" To 7/8"	3/4" To 1.1/8"	1.1/8" To 1.5/8"	1.5/8" To 2.1/8"
2.1/2	3	.259	2.1/4	10 & 11	.134 & .120	47.7	1.877	54.3	2.137	A-67/2	A-67/3	A-67/4	A-67/5	A-67/6
2.1/2	4 & 5	.238 & .220	2.1/4	12 & 13	.109 & .095	49.3	1.940	55.9	2.200	A-68/2	A-68/3	A-68/4	A-68/5	A-68/6
2.1/2	6 & 7	.203 & .180	2.1/4	14 - 16	.083 - .065	50.8	2.000	57.8	2.275	A-69/2	A-69/3	A-69/4	A-69/5	A-69/6
2.1/2	8 & 9	.165 & .148	2.3/4	3	.259	52.4	2.062	59.4	2.338	A-70/2	A-70/3	A-70/4	A-70/5	A-70/6
2.1/2	10 & 11	.134 & .120	2.3/4	4	.238	54.0	2.125	61.0	2.401	A-71/2	A-71/3	A-71/4	A-71/5	A-71/6
2.1/2	12 - 14	.109 - .083	2.3/4	5 & 6	.220 & .203	55.6	2.188	64.0	2.519	A-72/2	A-72/3	A-72/4	A-72/5	A-72/6
2.1/2	15 & 16	.072 & .065	2.3/4	7 & 8	.180 & .165	57.2	2.251	65.6	2.582	A-73/2	A-73/3	A-73/4	A-73/5	A-73/6
3	3	.259	2.3/4	9 & 10	.148 & .134	58.6	2.307	67.0	2.637	A-74/2	A-74/3	A-74/4	A-74/5	A-74/6
3	4	.238	2.3/4	11 - 13	.120 - .095	60.4	2.377	68.8	2.708	A-75/2	A-75/3	A-75/4	A-75/5	A-75/6
3	5 & 6	.220 & .203	2.3/4	14 - 16	.083 - .065	62.2	2.448	70.4	2.771	A-76/2	A-76/3	A-76/4	A-76/5	A-76/6
3	7 & 8	.180 & .165	-	-	-	63.6	2.503	72.0	2.834	A-77/2	A-77/3	A-77/4	A-77/5	A-77/6
3	9 & 10	.148 & .134	3.1/4	3	.259	65.0	2.559	73.4	2.889	A-78/2	A-78/3	A-78/4	A-78/5	A-78/6
3	11 - 13	.120 - .095	3.1/4	4	.238	66.6	2.622	75.0	2.952	A-79/2	A-79/3	A-79/4	A-79/5	A-79/6
3	14 - 16	.083 - .065	3.1/4	5 & 6	.220 & .203	68.3	2.688	76.9	3.027	A-80/2	A-80/3	A-80/4	A-80/5	A-80/6
3.1/2	2	.284	3.1/4	7 & 8	.180 & .165	69.9	2.751	78.5	3.090	A-81/2	A-81/3	A-81/4	A-81/5	A-81/6
3.1/2	3	.259	3.1/4	9 & 10	.148 & .134	71.5	2.814	80.1	3.153	A-82/2	A-82/3	A-82/4	A-82/5	A-82/6
3.1/2	4	.238	3.1/4	11 - 13	.120 - .095	73.1	2.877	81.7	3.216	A-83/2	A-83/3	A-83/4	A-83/5	A-83/6
3.1/2	5 & 6	.220 & .203	3.1/4	14 - 16	.083 - .065	74.6	2.937	84.2	3.314	A-84/2	A-84/3	A-84/4	A-84/5	A-84/6
3.1/2	7 & 8	.180 & .165	3.3/4	2	.084	76.2	3.000	85.5	3.366	A-85/2	A-85/3	A-85/4	A-85/5	A-85/6
3.1/2	9 - 10	.148 - .120	3.3/4	3	.259	77.8	3.062	87.4	3.440	A-86/2	A-86/3	A-86/4	A-86/5	A-86/6
3.1/2	12 - 16	.109 - .065	3.3/4	4	.238	79.4	3.125	89.0	3.503	A-87/2	A-87/3	A-87/4	A-87/5	A-87/6
			3.3/4	5 & 6	.220 & .203	81.0	3.188	90.6	3.566	A-88/2	A-88/3	A-88/4	A-88/5	A-88/6
4	2	.284	3.3/4	7 & 8	.180 & .165	82.6	3.251	92.2	3.629	A-89/2	A-89/3	A-89/4	A-89/5	A-89/6
4	3	.259	3.3/4	9 & 10	.148 & .134	84.2	3.314	93.8	3.629	A-90/2	A-90/3	A-90/4	A-90/5	A-90/6
4	4	.238	3.3/4	11 - 13	.120 - .095	85.8	3.377	96.2	3.787	A-91/2	A-91/3	A-91/4	A-91/5	A-91/6
4	5 & 6	.220 & .203	3.3/4	14 - 16	.083 - .065	87.4	3.440	97.8	3.850	A-92/2	A-92/3	A-92/4	A-92/5	A-92/6
4	7 & 8	.180 & .165	4.1/4	2		89.0	3.503	99.4	3.913	A-93/2	A-93/3	A-93/4	A-93/5	A-93/6
4	9 - 11	.148 - .120	4.1/4	3	.284	90.4	3.559	100.8	3.968	A-94/2	A-94/3	A-94/4	A-94/5	A-94/6
4	12 - 16	.109 - .065	4.1/4	4	.238	92.0	3.622	102.4	4.031	A-95/2	A-95/3	A-95/4	A-95/5	A-95/6
			4.1/4	5 & 6	.220 & .203	93.4	3.677	103.8	4.086	A-96/2	A-96/3	A-96/4	A-96/5	A-96/6
4.1/2	2	.284	4.1/4	7 & 8	.180 & .165	95.0	3.740	105.4	4.149	A-97/2	A-97/3	A-97/4	A-97/5	A-97/6
4.1/2	3	.259	4.1/4	9 - 11	.148 - .120	96.6	3.803	107.0	4.212	A-98/2	A-98/3	A-98/4	A-98/5	A-98/6
4.1/2	4 & 5	.238 & .220	4.1/4	11 - 13	.120 - .095	98.2	3.866	108.6	4.275	A-99/2	A-99/3	A-99/4	A-99/5	A-99/6
4.1/2	6 & 7	.203 & .180	-	-	-	101.2	3.984	110.0	4.330	A-100/2	A-100/3	A-100/4	A-100/5	A-100/6
4.1/2	8 & 9	.165 & .148	-	-	-	102.8	4.047	111.6	4.393	A-101/2	A-101/3	A-101/4	A-101/5	A-101/6
4.1/2	10 - 12	.134 - .109	-	-	-	104.4	4.110	113.2	4.456	A-102/2	A-102/3	A-102/4	A-102/5	A-102/6

# A SERIES

7/8" - 4 1/2"  
O.D.

A SERIES

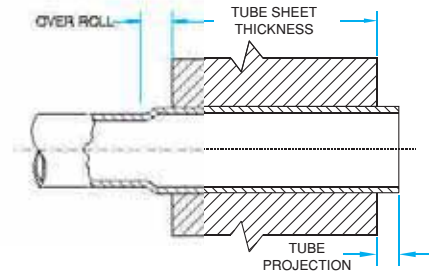

Spare Rollers Set Model Number Tube Sheet Thickness Range					Mandrel Square Drive Size inch	Spare Mandrel Model Number		
1/2" To 7/8"	3/4" To 1.1/8"	1.1/8" To 1.5/8"	1.5/8" To 2.1/8"	2.1/8" To 2.5/8"		Drum Type	Header Type	Short Series Mandrel Set (No. Of Mandrels)
43-2-RS	43-3-RS	43-4-RS	43-5-RS	43-6-RS	3/4	DM-23	HM-23	SM-23 (3)
44-2-RS	44-3-RS	44-4-RS	44-5-RS	44-6-RS	3/4	DM-23	HM-23	SM-23 (3)
43-2-RS	43-3-RS	43-4-RS	43-5-RS	43-6-RS	3/4	DM-24	HM-24	SM-24 (3)
44-2-RS	44-3-RS	44-4-RS	44-5-RS	44-6-RS	3/4	DM-24	HM-24	SM-24 (3)
45-2-RS	45-3-RS	45-4-RS	45-5-RS	45-6-RS	3/4	DM-24	HM-24	SM-24 (3)
47-2-RS	47-3-RS	47-4-RS	47-5-RS	47-6-RS	3/4	DM-24	HM-24	SM-24 (3)
46-2-RS	46-3-RS	46-4-RS	46-5-RS	46-6-RS	1	DM-25	HM-25	SM-25 (3)
47-2-RS	47-3-RS	47-4-RS	47-5-RS	47-6-RS	1	DM-25	HM-25	SM-25 (3)
48-2-RS	48-3-RS	48-4-RS	48-5-RS	48-6-RS	1	DM-25	HM-25	SM-25 (3)
49-2-RS	49-3-RS	49-4-RS	49-5-RS	49-6-RS	1	DM-25	HM-25	SM-25 (3)
50-2-RS	50-3-RS	50-4-RS	50-5-RS	50-6-RS	1	DM-25	HM-25	SM-25 (3)
51-2-RS	51-3-RS	51-4-RS	51-5-RS	51-6-RS	1	DM-25	HM-25	SM-25 (3)
52-2-RS	52-3-RS	52-4-RS	52-5-RS	52-6-RS	1	DM-25	HM-25	SM-25 (3)
51-2-RS	51-3-RS	51-4-RS	51-5-RS	51-6-RS	1	DM-26	HM-26	SM-26 (4)
52-2-RS	52-3-RS	52-4-RS	52-5-RS	52-6-RS	1	DM-26	HM-26	SM-26 (4)
53-2-RS	53-3-RS	53-4-RS	53-5-RS	53-6-RS	1	DM-26	HM-26	SM-26 (4)
54-2-RS	54-3-RS	54-4-RS	54-5-RS	54-6-RS	1	DM-26	HM-26	SM-26 (4)
54-2-RS	54-3-RS	54-4-RS	54-5-RS	54-6-RS	1	DM-27	HM-27	SM-27 (4)
55-2-RS	55-3-RS	55-4-RS	55-5-RS	55-6-RS	1	DM-27	HM-27	SM-27 (4)
56-2-RS	56-3-RS	56-4-RS	56-5-RS	56-6-RS	1	DM-27	HM-27	SM-27 (4)
57-2-RS	57-3-RS	57-4-RS	57-5-RS	57-6-RS	1	DM-27	HM-27	SM-27 (4)
58-2-RS	58-3-RS	58-4-RS	58-5-RS	58-6-RS	1	DM-27	HM-27	SM-27 (4)
59-2-RS	59-3-RS	59-4-RS	59-5-RS	59-6-RS	1	DM-27	HM-27	SM-27 (4)
60-2-RS	60-3-RS	60-4-RS	60-5-RS	60-6-RS	1	DM-27	HM-27	SM-27 (4)
59-2-RS	59-3-RS	59-4-RS	59-5-RS	59-6-RS	1	DM-28	HM-28	SM-28 (4)
60-2-RS	60-3-RS	60-4-RS	60-5-RS	60-6-RS	1	DM-28	HM-28	SM-28 (4)
61-2-RS	61-3-RS	61-4-RS	61-5-RS	61-6-RS	1	DM-28	HM-28	SM-28 (4)
62-2-RS	62-3-RS	62-4-RS	62-5-RS	62-6-RS	1	DM-28	HM-28	SM-28 (4)
63-2-RS	63-3-RS	63-4-RS	63-5-RS	63-6-RS	1	DM-28	HM-28	SM-28 (4)
62-2-RS	62-3-RS	62-4-RS	62-5-RS	62-6-RS	1	DM-29	HM-29	SM-29 (4)
63-2-RS	63-3-RS	63-4-RS	63-5-RS	63-6-RS	1	DM-29	HM-29	SM-29 (4)
64-2-RS	64-3-RS	64-4-RS	64-5-RS	64-6-RS	1	DM-29	HM-29	SM-29 (4)
63-2-RS	63-3-RS	63-4-RS	63-5-RS	63-6-RS	1	DM-30	HM-30	SM-30 (4)
64-2-RS	64-3-RS	64-4-RS	64-5-RS	64-6-RS	1	DM-30	HM-30	SM-30 (4)
65-2-RS	65-3-RS	65-4-RS	65-5-RS	65-6-RS	1	DM-30	HM-30	SM-30 (4)
66-2-RS	66-3-RS	66-4-RS	66-5-RS	66-6-RS	1	DM-30	HM-30	SM-30 (4)

7/8" - 4 1/2"  
O.D.

AF3 SERIES

- Features :**
- Best 'Value For Money' tool in the world when flaring of tube ends is needed.
  - Sturdy construction with rolls self contained in cage.
  - Time tested, durable design.
  - Overlapping flare rolls prevent ridging of tube.
  - Use - Economical tool used for applications where small number of tubes are to be expanded with flaring.

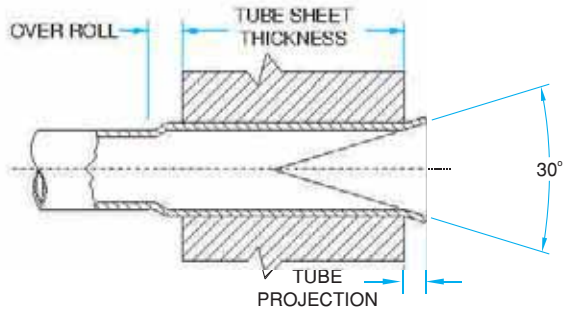
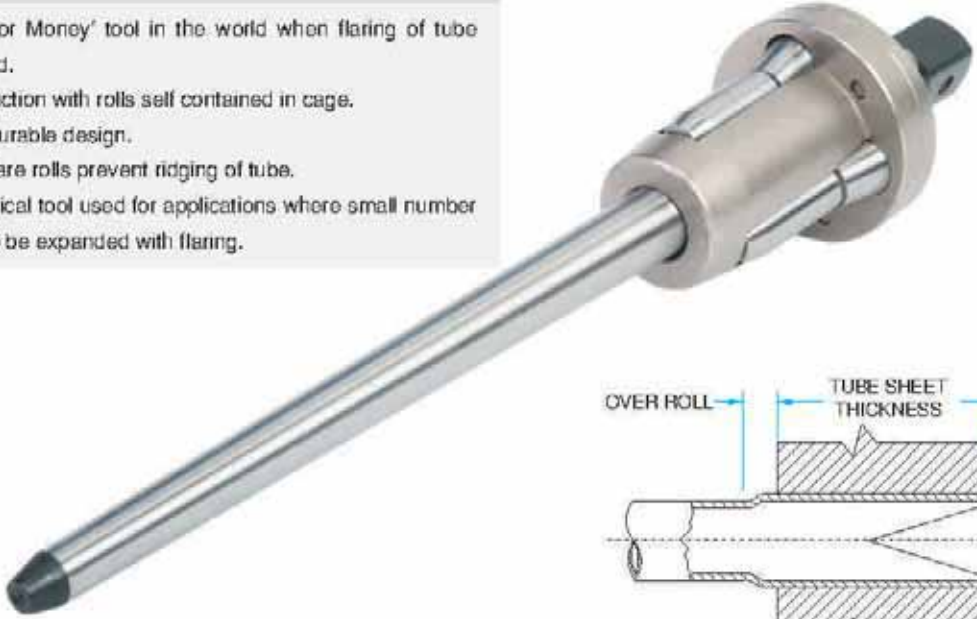

Tube O.D.	Tube Thickness		Tube O.D.	Tube Thickness		Minimum I.D. Tool Enters		Maximum Expansion Of Tool		Tube Expander Model Number Tube Sheet Thickness Range				
	inch	bwg		inch	bwg	inch	mm	inch	mm	inch	1/2" To 7/8"	3/4" To 1.1/8"	1.1/8" To 1.5/8"	1.5/8" To 2.1/8"
7/8	15	.072	1	10	.134	18.1	.712	20.4	.803	AF3-31/2	AF3-31/3	-	-	-
7/8	16	.065				18.4	.724	20.7	.814	AF3-32/2	AF3-32/3	-	-	-
7/8	17	.058	1	11	.120	18.8	.740	21.1	.830	AF3-33/2	AF3-33/3	-	-	-
7/8	18	.049	1	12	.109	19.4	.763	21.6	.850	AF3-34/2	AF3-34/3	-	-	-
7/8	19 & 20	.042 & .035	1.1/8	8	.165	19.7	.775	22.3	.877	AF3-35/2	AF3-35/3	-	-	-
1	13	.095				20.1	.791	22.4	.881	AF3-36/2	AF3-36/3	-	-	-
1	14	.083	1.1/8	9	.148	20.6	.811	23.1	.909	AF3-37/2	AF3-37/3	AF3-37/4	-	-
1	15 & 16	.072 & .065	1.1/8	10	.134	21.3	.838	23.8	.937	AF3-38/2	AF3-38/3	AF3-38/4	-	-
1	17 & 18	.058 & .048	1.1/8	11	.120	22.0	.866	24.5	.964	AF3-39/2	AF3-39/3	AF3-39/4	-	-
1	19 & 20	.042 & .035	1.1/8	12	.109	22.4	.881	25.0	.984	AF3-40/2	AF3-40/3	AF3-40/4	-	-
1.1/4	8	.165	1.1/8	13	.095	23.3	.917	25.9	1.019	AF3-41/2	AF3-41/3	AF3-41/4	-	-
1.1/4	9	.148	1.1/8	14	.083	23.8	.937	26.5	1.043	AF3-42/2	AF3-42/3	AF3-42/4	-	-
1.1/4	10	.134	1.1/8	15 & 16	.072 & .065	24.4	.960	27.2	1.070	AF3-43/2	AF3-43/3	AF3-43/4	-	-
1.1/4	11	.120				25.2	.992	28.0	1.102	AF3-44/2	AF3-44/3	AF3-44/4	-	-
1.1/4	12	.109				25.7	1.011	28.5	1.122	AF3-45/2	AF3-45/3	AF3-45/4	-	-
1.1/4	13	.095	1.3/8	8	.165	26.1	1.027	28.8	1.133	AF3-46/2	AF3-46/3	AF3-46/4	-	-
1.1/4	14	.083				26.4	1.039	29.2	1.149	AF3-47/2	AF3-47/3	AF3-47/4	-	-
1.1/4	15	.072	1.3/8	9	.148	26.9	1.059	29.7	1.169	AF3-48/2	AF3-48/3	AF3-48/4	-	-
1.1/4	16	.065	1.3/8	10	.134	27.6	1.086	30.4	1.196	AF3-49/2	AF3-49/3	AF3-49/4	AF3-49/5	AF3-49/6
1.1/2	7	.180	1.3/8	11	.120	28.3	1.114	31.2	1.228	AF3-50/2	AF3-50/3	AF3-50/4	AF3-50/5	AF3-50/6
1.1/2	8	.165	1.3/8	12	.109	28.8	1.133	31.7	1.248	AF3-51/2	AF3-51/3	AF3-51/4	AF3-51/5	AF3-51/6
1.1/2	9	.148	1.3/8	13 & 14	.095 & .083	29.5	1.161	33.4	1.314	AF3-52/2	AF3-52/3	AF3-52/4	AF3-52/5	AF3-52/6
1.1/2	10	.134	1.3/8	15 & 16	.072 & .065	30.0	1.181	34.1	1.342	AF3-53/2	AF3-53/3	AF3-53/4	AF3-53/5	AF3-53/6
1.1/2	11 & 12	.120 & .109				30.6	1.204	34.8	1.370	AF3-54/2	AF3-54/3	AF3-54/4	AF3-54/5	AF3-54/6
1.1/2	13	.095	1.3/4	5	.220	31.4	1.236	35.6	1.401	AF3-55/2	AF3-55/3	AF3-55/4	AF3-55/5	AF3-55/6
1.1/2	14 & 15	.083 & .072	1.3/4	6	.203	32.6	1.283	36.8	1.448	AF3-56/2	AF3-56/3	AF3-56/4	AF3-56/5	AF3-56/6
			1.3/4	7	.180	33.4	1.314	38.1	1.500	AF3-57/2	AF3-57/3	AF3-57/4	AF3-57/5	AF3-57/6
			1.3/4	8	.165	34.2	1.346	38.7	1.523	AF3-58/2	AF3-58/3	AF3-58/4	AF3-58/5	AF3-58/6
2	3	.259	1.3/4	9 & 10	.148 & .134	35.0	1.377	40.6	1.598	AF3-59/2	AF3-59/3	AF3-59/4	AF3-59/5	AF3-59/6
2	4	.238	1.3/4	11 & 12	.120 & .109	36.6	1.440	42.2	1.661	AF3-60/2	AF3-60/3	AF3-60/4	AF3-60/5	AF3-60/6
2	5 & 6	.220 & .203	1.3/4	13 & 14	.095 & .083	38.2	1.503	43.8	1.712	AF3-61/2	AF3-61/3	AF3-61/4	AF3-61/5	AF3-61/6
2	7 & 8	.180 & .165	1.3/4	15 & 16	.072 & .065	39.8	1.566	45.4	1.787	AF3-62/2	AF3-62/3	AF3-62/4	AF3-62/5	AF3-62/6
2	9 & 10	.148 & .134	2.1/4	3	.259	41.4	1.629	47.0	1.850	AF3-63/2	AF3-63/3	AF3-63/4	AF3-63/5	AF3-63/6
2	11 - 13	.120 - .095	2.1/4	4	.238	42.9	1.688	49.5	1.948	AF3-64/2	AF3-64/3	AF3-64/4	AF3-64/5	AF3-64/6
2	14 - 16	.083 - .065	2.1/4	6 & 7	.203 & .180	44.5	1.751	51.1	2.011	AF3-65/2	AF3-65/3	AF3-65/4	AF3-65/5	AF3-65/6
2	17 & 18	.058 & .049	2.1/4	8 & 9	.165 & .148	46.1	1.814	52.7	2.074	AF3-66/2	AF3-66/3	AF3-66/4	AF3-66/5	AF3-66/6



# AF3 SERIES

7/8" - 4 1/2"  
O.D.

AF3 SERIES

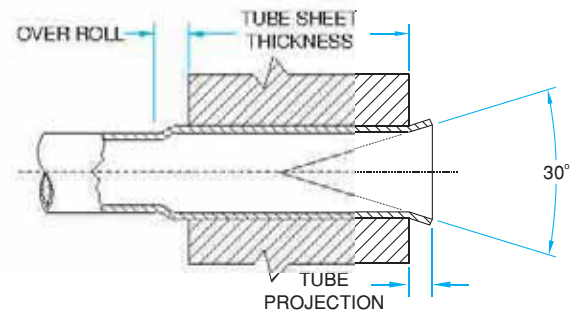
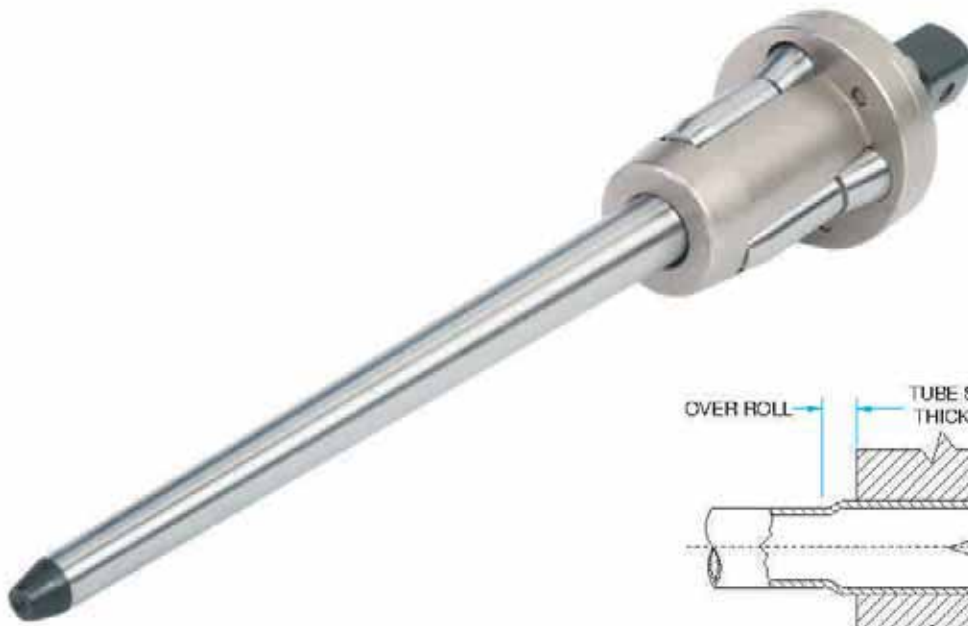

Spare Rollers Set Model Number Tube Sheet Thickness Range					Mandrel Square Drive Size inch	Spare Mandrel Model Number		
1/2" To 7/8"	3/4" To 1.1/8"	1.1/8" To 1.5/8"	1.5/8" To 2.1/8"	2.1/8" To 2.5/8"		Drum Type	Header Type	Short Series Mandrel Set (No. Of Mandrels)
15-2-F3S	15-3-F3S	-	-	-	3/8	DM-11	-	-
15-2-F3S	15-3-F3S	-	-	-	3/8	DM-12	-	-
16-2-F3S	16-3-F3S	-	-	-	3/8	DM-12	-	-
20-2-F3S	20-3-F3S	-	-	-	3/8	DM-12	-	-
17-2-F3S	17-3-F3S	-	-	-	3/8	DM-13	-	-
18-2-F3S	18-3-F3S	-	-	-	3/8	DM-12	-	-
18-2-F3S	18-3-F3S	18-4-F3S	-	-	3/8	DM-13	HM-13	SM-13 (2)
19-2-F3S	19-3-F3S	19-4-F3S	-	-	3/8	DM-13	HM-13	SM-13 (2)
21-2-F3S	21-3-F3S	21-4-F3S	-	-	3/8	DM-13	HM-13	SM-13 (2)
21-2-F3S	21-3-F3S	21-4-F3S	-	-	3/8	DM-14	HM-14	SM-14 (2)
22-2-F3S	22-3-F3S	22-4-F3S	-	-	3/8	DM-14	HM-14	SM-14 (2)
23-2-F3S	23-3-F3S	23-4-F3S	-	-	1/2	DM-15	HM-15	SM-15 (2)
24-2-F3S	24-3-F3S	24-4-F3S	-	-	1/2	DM-15	HM-15	SM-15 (2)
26-2-F3S	26-3-F3S	26-4-F3S	-	-	1/2	DM-16	HM-16	SM-16 (2)
27-2-F3S	27-3-F3S	27-4-F3S	-	-	1/2	DM-16	HM-16	SM-16 (2)
31-2-F3S	31-3-F3S	31-4-F3S	-	-	1/2	DM-16	HM-16	SM-16 (2)
28-2-F3S	28-3-F3S	28-4-F3S	-	-	1/2	DM-17	HM-17	SM-17 (2)
29-2-F3S	29-3-F3S	29-4-F3S	-	-	1/2	DM-17	HM-17	SM-17 (2)
30-2-F3S	30-3-F3S	30-4-F3S	30-5-F3S	30-6-F3S	1/2	DM-17	HM-17	SM-17 (2)
30-2-F3S	30-3-F3S	30-4-F3S	30-5-F3S	30-6-F3S	1/2	DM-18	HM-18	SM-18 (2)
34-2-F3S	34-3-F3S	34-4-F3S	34-5-F3S	34-6-F3S	1/2	DM-18	HM-18	SM-18 (2)
28-2-F3S	28-3-F3S	28-4-F3S	28-5-F3S	28-6-F3S	1/2	DM-20	HM-20	SM-20 (2)
29-2-F3S	29-3-F3S	29-4-F3S	29-5-F3S	29-6-F3S	1/2	DM-20	HM-20	SM-20 (2)
30-2-F3S	30-3-F3S	30-4-F3S	30-5-F3S	30-6-F3S	1/2	DM-20	HM-20	SM-20 (2)
33-2-F3S	33-3-F3S	33-4-F3S	33-5-F3S	33-6-F3S	1/2	DM-20	HM-20	SM-20 (2)
32-2-F3S	32-3-F3S	32-4-F3S	32-5-F3S	32-6-F3S	1/2	DM-21	HM-21	SM-21 (2)
36-2-F3S	36-3-F3S	36-4-F3S	36-5-F3S	36-6-F3S	1/2	DM-21	HM-21	SM-21 (2)
37-2-F3S	37-3-F3S	37-4-F3S	37-5-F3S	37-6-F3S	1/2	DM-21	HM-21	SM-21 (2)
33-2-F3S	33-3-F3S	33-4-F3S	33-5-F3S	33-6-F3S	3/4	DM-22	HM-22	SM-22 (3)
37-2-F3S	37-3-F3S	37-4-F3S	37-5-F3S	37-6-F3S	3/4	DM-22	HM-22	SM-22 (3)
38-2-F3S	38-3-F3S	38-4-F3S	38-5-F3S	38-6-F3S	3/4	DM-22	HM-22	SM-22 (3)
39-2-F3S	39-3-F3S	39-4-F3S	39-5-F3S	39-6-F3S	3/4	DM-22	HM-22	SM-22 (3)
40-2-F3S	40-3-F3S	40-4-F3S	40-5-F3S	40-6-F3S	3/4	DM-22	HM-22	SM-22 (3)
40-2-F3S	40-3-F3S	40-4-F3S	40-5-F3S	40-6-F3S	3/4	DM-23	HM-23	SM-23 (3)
41-2-F3S	41-3-F3S	41-4-F3S	41-5-F3S	41-6-F3S	3/4	DM-23	HM-23	SM-23 (3)
42-2-F3S	42-3-F3S	42-4-F3S	42-5-F3S	42-6-F3S	3/4	DM-23	HM-23	SM-23 (3)

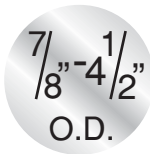

AF3 SERIES

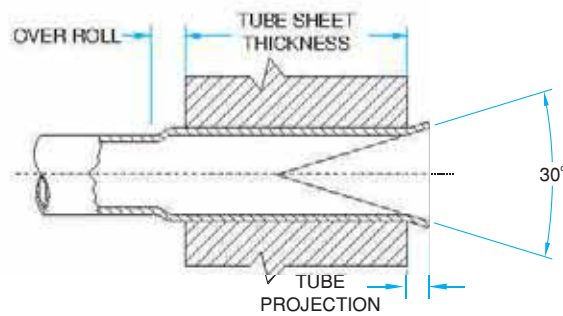
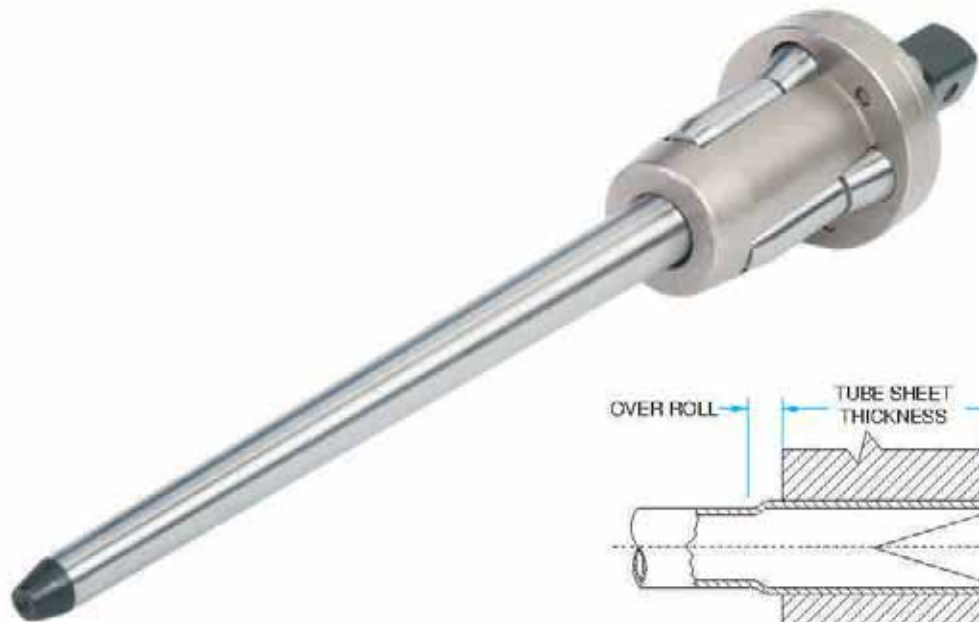

Tube O.D.	Tube Thickness		Tube O.D.	Tube Thickness		Minimum I.D. Tool Enters		Maximum Expansion Of Tool		Tube Expander Model Number Tube Sheet Thickness Range				
	inch	bwg		inch	bwg	inch	mm	inch	mm	inch	1/2" To 7/8"	3/4" To 1.1/8"	1.1/8" To 1.5/8"	1.5/8" To 2.1/8"
2.1/2	3	.259	2.1/4	10 & 11	.134 & .120	47.7	1.877	54.3	2.137	AF3-67/2	AF3-67/3	AF3-67/4	AF3-67/5	AF3-67/6
2.1/2	4 & 5	.238 & .220	2.1/4	12 & 13	.109 & .095	49.3	1.940	55.9	2.200	AF3-68/2	AF3-68/3	AF3-68/4	AF3-68/5	AF3-68/6
2.1/2	6 & 7	.203 & .180	2.1/4	14 - 16	.083 - .065	50.8	2.000	57.8	2.275	AF3-69/2	AF3-69/3	AF3-69/4	AF3-69/5	AF3-69/6
2.1/2	8 & 9	.165 & .148	2.3/4	3	.259	52.4	2.062	59.4	2.338	AF3-70/2	AF3-70/3	AF3-70/4	AF3-70/5	AF3-70/6
2.1/2	10 & 11	.134 & .120	2.3/4	4	.238	54.0	2.125	61.0	2.401	AF3-71/2	AF3-71/3	AF3-71/4	AF3-71/5	AF3-71/6
2.1/2	12 - 14	.109 - .083	2.3/4	5 & 6	.220 & .203	55.6	2.188	64.0	2.519	AF3-72/2	AF3-72/3	AF3-72/4	AF3-72/5	AF3-72/6
2.1/2	15 & 16	.072 & .065	2.3/4	7 & 8	.180 & .165	57.2	2.251	65.6	2.582	AF3-73/2	AF3-73/3	AF3-73/4	AF3-73/5	AF3-73/6
3	3	.259	2.3/4	9 & 10	.148 & .134	58.6	2.307	67.0	2.637	AF3-74/2	AF3-74/3	AF3-74/4	AF3-74/5	AF3-74/6
3	4	.238	2.3/4	11 - 13	.120 - .095	60.4	2.377	68.8	2.708	AF3-75/2	AF3-75/3	AF3-75/4	AF3-75/5	AF3-75/6
3	5 & 6	.220 & .203	2.3/4	14 - 16	.083 - .065	62.2	2.448	70.4	2.771	AF3-76/2	AF3-76/3	AF3-76/4	AF3-76/5	AF3-76/6
3	7 & 8	.180 & .165				63.6	2.503	72.0	2.834	AF3-77/2	AF3-77/3	AF3-77/4	AF3-77/5	AF3-77/6
3	9 & 10	.148 & .134	3.1/4	3	.259	65.0	2.559	73.4	2.889	AF3-78/2	AF3-78/3	AF3-78/4	AF3-78/5	AF3-78/6
3	11 - 13	.120 - .095	3.1/4	4	.238	66.6	2.622	75.0	2.952	AF3-79/2	AF3-79/3	AF3-79/4	AF3-79/5	AF3-79/6
3	14 - 16	.083 - .065	3.1/4	5 & 6	.220 & .203	68.3	2.688	76.9	3.027	AF3-80/2	AF3-80/3	AF3-80/4	AF3-80/5	AF3-80/6
3.1/2	2	.284	3.1/4	7 & 8	.180 & .165	69.9	2.751	78.5	3.090	AF3-81/2	AF3-81/3	AF3-81/4	AF3-81/5	AF3-81/6
3.1/2	3	.259	3.1/4	9 & 10	.148 & .134	71.5	2.814	80.1	3.153	AF3-82/2	AF3-82/3	AF3-82/4	AF3-82/5	AF3-82/6
3.1/2	4	.238	3.1/4	11 - 13	.120 - .095	73.1	2.877	81.7	3.216	AF3-83/2	AF3-83/3	AF3-83/4	AF3-83/5	AF3-83/6
3.1/2	5 & 6	.220 & .203	3.1/4	14 - 16	.083 - .065	74.6	2.937	84.2	3.314	AF3-84/2	AF3-84/3	AF3-84/4	AF3-84/5	AF3-84/6
3.1/2	7 & 8	.180 & .165	3.3/4	2	.284	76.2	3.000	85.5	3.366	AF3-85/2	AF3-85/3	AF3-85/4	AF3-85/5	AF3-85/6
3.1/2	9 - 11	.148 - .120	3.3/4	3	.259	77.8	3.062	87.4	3.440	AF3-86/2	AF3-86/3	AF3-86/4	AF3-86/5	AF3-86/6
3.1/2	12 - 16	.109 - .065	3.3/4	4	.238	79.4	3.125	89.0	3.503	AF3-87/2	AF3-87/3	AF3-87/4	AF3-87/5	AF3-87/6
			3.3/4	5 & 6	.220 & .203	81.0	3.188	90.6	3.566	AF3-88/2	AF3-88/3	AF3-88/4	AF3-88/5	AF3-88/6
4	2	.284	3.3/4	7 & 8	.180 & .165	82.6	3.251	92.2	3.629	AF3-89/2	AF3-89/3	AF3-89/4	AF3-89/5	AF3-89/6
4	3	.259	3.3/4	9 & 10	.148 & .134	84.2	3.314	93.8	3.692	AF3-90/2	AF3-90/3	AF3-90/4	AF3-90/5	AF3-90/6
4	4	.238	3.3/4	11 - 13	.120 - .095	85.8	3.377	96.2	3.787	AF3-91/2	AF3-91/3	AF3-91/4	AF3-91/5	AF3-91/6
4	5 & 6	.220 & .203	3.3/4	14 - 16	.083 - .065	87.4	3.440	97.8	3.850	AF3-92/2	AF3-92/3	AF3-92/4	AF3-92/5	AF3-92/6
4	7 & 8	.180 & .165	4.1/4	2	.284	89.0	3.503	99.4	3.913	AF3-93/2	AF3-93/3	AF3-93/4	AF3-93/5	AF3-93/6
4	9 - 11	.148 - .120	4.1/4	3	.259	90.4	3.559	100.8	3.968	AF3-94/2	AF3-94/3	AF3-94/4	AF3-94/5	AF3-94/6
4	12 - 16	.109 - .065	4.1/4	4	.238	92.0	3.622	102.4	4.031	AF3-95/2	AF3-95/3	AF3-95/4	AF3-95/5	AF3-95/6
			4.1/4	5 & 6	.220 & .203	93.4	3.677	103.8	4.086	AF3-96/2	AF3-96/3	AF3-96/4	AF3-96/5	AF3-96/6
4.1/2	2	.284	4.1/4	7 & 8	.180 & .165	95.0	3.740	105.4	4.149	AF3-97/2	AF3-97/3	AF3-97/4	AF3-97/5	AF3-97/6
4.1/2	3	.259	4.1/4	9 - 11	.148 - .120	96.6	3.803	107.0	4.212	AF3-98/2	AF3-98/3	AF3-98/4	AF3-98/5	AF3-98/6
4.1/2	4 & 5	.238 & .220	4.1/4	11 - 13	.120 - .095	98.2	3.866	108.6	4.275	AF3-99/2	AF3-99/3	AF3-99/4	AF3-99/5	AF3-99/6
4.1/2	6 & 7	.203 & .180				101.2	3.984	110.0	4.330	AF3-100/2	AF3-100/3	AF3-100/4	AF3-100/5	AF3-100/6
4.1/2	8 & 9	.165 & .148				102.8	4.047	111.6	4.393	AF3-101/2	AF3-101/3	AF3-101/4	AF3-101/5	AF3-101/6
4.1/2	10 - 12	.134 - .109				104.4	4.110	113.2	4.456	AF3-102/2	AF3-102/3	AF3-102/4	AF3-102/5	AF3-102/6

# AF3 SERIES

7/8" - 4 1/2"  
O.D.

AF3 SERIES

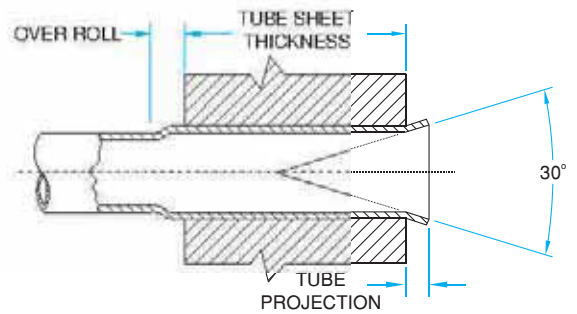
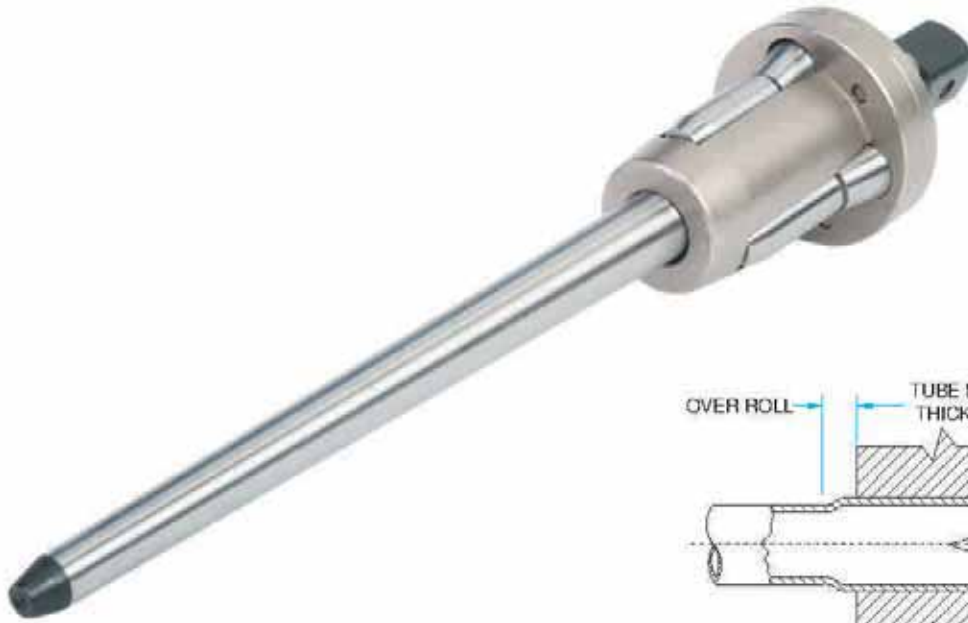

Spare Rollers Set Model Number Tube Sheet Thickness Range					Mandrel Square Drive Size inch	Spare Mandrel Model Number		
1/2" To 7/8"	3/4" To 1.1/8"	1.1/8" To 1.5/8"	1.5/8" To 2.1/8"	2.1/8" To 2.5/8"		Drum Type	Header Type	Short Series Mandrel Set (No. Of Mandrels)
43-2-F3S	43-3-F3S	43-4-F3S	43-5-F3S	43-6-F3S	3/4	DM-23	HM-23	SM-23 (3)
44-2-F3S	44-3-F3S	44-4-F3S	44-5-F3S	44-6-F3S	3/4	DM-23	HM-23	SM-23 (3)
43-2-F3S	43-3-F3S	43-4-F3S	43-5-F3S	43-6-F3S	3/4	DM-24	HM-24	SM-24 (3)
44-2-F3S	44-3-F3S	44-4-F3S	44-5-F3S	44-6-F3S	3/4	DM-24	HM-24	SM-24 (3)
45-2-F3S	45-3-F3S	45-4-F3S	45-5-F3S	45-6-F3S	3/4	DM-24	HM-24	SM-24 (3)
47-2-F3S	47-3-F3S	47-4-F3S	47-5-F3S	47-6-F3S	3/4	DM-24	HM-24	SM-24 (3)
46-2-F3S	46-3-F3S	46-4-F3S	46-5-F3S	46-6-F3S	1	DM-25	HM-25	SM-25 (3)
47-2-F3S	47-3-F3S	47-4-F3S	47-5-F3S	47-6-F3S	1	DM-25	HM-25	SM-25 (3)
48-2-F3S	48-3-F3S	48-4-F3S	48-5-F3S	48-6-F3S	1	DM-25	HM-25	SM-25 (3)
49-2-F3S	49-3-F3S	49-4-F3S	49-5-F3S	49-6-F3S	1	DM-25	HM-25	SM-25 (3)
50-2-F3S	50-3-F3S	50-4-F3S	50-5-F3S	50-6-F3S	1	DM-25	HM-25	SM-25 (3)
51-2-F3S	51-3-F3S	51-4-F3S	51-5-F3S	51-6-F3S	1	DM-25	HM-25	SM-25 (3)
52-2-F3S	52-3-F3S	52-4-F3S	52-5-F3S	52-6-F3S	1	DM-25	HM-25	SM-25 (3)
51-2-F3S	51-3-F3S	51-4-F3S	51-5-F3S	51-6-F3S	1	DM-26	HM-26	SM-26 (4)
52-2-F3S	52-3-F3S	52-4-F3S	52-5-F3S	52-6-F3S	1	DM-26	HM-26	SM-26 (4)
53-2-F3S	53-3-F3S	53-4-F3S	53-5-F3S	53-6-F3S	1	DM-26	HM-26	SM-26 (4)
54-2-F3S	54-3-F3S	54-4-F3S	54-5-F3S	54-6-F3S	1	DM-26	HM-26	SM-26 (4)
54-2-F3S	54-3-F3S	54-4-F3S	54-5-F3S	54-6-F3S	1	DM-27	HM-27	SM-27 (4)
55-2-F3S	55-3-F3S	55-4-F3S	55-5-F3S	55-6-F3S	1	DM-27	HM-27	SM-27 (4)
56-2-F3S	56-3-F3S	56-4-F3S	56-5-F3S	56-6-F3S	1	DM-27	HM-27	SM-27 (4)
57-2-F3S	57-3-F3S	57-4-F3S	57-5-F3S	57-6-F3S	1	DM-27	HM-27	SM-27 (4)
58-2-F3S	58-3-F3S	58-4-F3S	58-5-F3S	58-6-F3S	1	DM-27	HM-27	SM-27 (4)
59-2-F3S	59-3-F3S	59-4-F3S	59-5-F3S	59-6-F3S	1	DM-27	HM-27	SM-27 (4)
60-2-F3S	60-3-F3S	60-4-F3S	60-5-F3S	60-6-F3S	1	DM-27	HM-27	SM-27 (4)
59-2-F3S	59-3-F3S	59-4-F3S	59-5-F3S	59-6-F3S	1	DM-28	HM-28	SM-28 (4)
60-2-F3S	60-3-F3S	60-4-F3S	60-5-F3S	60-6-F3S	1	DM-28	HM-28	SM-28 (4)
61-2-F3S	61-3-F3S	61-4-F3S	61-5-F3S	61-6-F3S	1	DM-28	HM-28	SM-28 (4)
62-2-F3S	62-3-F3S	62-4-F3S	62-5-F3S	62-6-F3S	1	DM-28	HM-28	SM-28 (4)
63-2-F3S	63-3-F3S	63-4-F3S	63-5-F3S	63-6-F3S	1	DM-28	HM-28	SM-28 (4)
62-2-F3S	62-3-F3S	62-4-F3S	62-5-F3S	62-6-F3S	1	DM-29	HM-29	SM-29 (4)
63-2-F3S	63-3-F3S	63-4-F3S	63-5-F3S	63-6-F3S	1	DM-29	HM-29	SM-29 (4)
64-2-F3S	64-3-F3S	64-4-F3S	64-5-F3S	64-6-F3S	1	DM-29	HM-29	SM-29 (4)
63-2-F3S	63-3-F3S	63-4-F3S	63-5-F3S	63-6-F3S	1	DM-30	HM-30	SM-30 (4)
64-2-F3S	64-3-F3S	64-4-F3S	64-5-F3S	64-6-F3S	1	DM-30	HM-30	SM-30 (4)
65-2-F3S	65-3-F3S	65-4-F3S	65-5-F3S	65-6-F3S	1	DM-30	HM-30	SM-30 (4)
66-2-F3S	66-3-F3S	66-4-F3S	66-5-F3S	66-6-F3S	1	DM-30	HM-30	SM-30 (4)

7/8" - 4 1/2"  
O.D.

AB SERIES WITH BEARING

- Features :*
- Similar to 'A' Series expanders (Pg. 66)
  - Bearing reduces frictional build up for smoother expanding cycles.
  - Bearing increases useful life of tool.
  - Use - High productivity tool used where flaring of tubes is not needed.

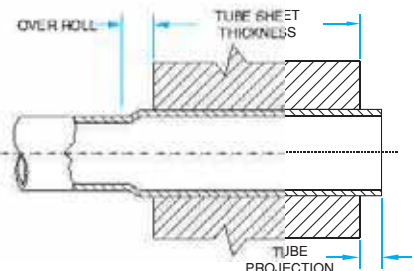

Tube O.D.	Tube Thickness		Tube O.D.	Tube Thickness		Minimum I.D. Tool Enters		Maximum Expansion Of Tool		Tube Expander Model Number Tube Sheet Thickness Range				
	inch	bwg		inch	bwg	inch	mm	inch	mm	inch	1/2" To 7/8"	3/4" To 1.1/8"	1.1/8" To 1.5/8"	1.5/8" To 2.1/8"
7/8	15	.072	1	10	.134	18.1	.712	20.4	.803	AB-31/2	AB-31/3	-	-	-
7/8	16	.065				18.4	.724	20.7	.814	AB-32/2	AB-32/3	-	-	-
7/8	17	.058	1	11	.120	18.8	.740	21.1	.830	AB-33/2	AB-33/3	-	-	-
7/8	18	.049	1	12	.109	19.4	.763	21.6	.850	AB-34/2	AB-34/3	-	-	-
7/8	19 & 20	.042 & .035	1.1/8	8	.165	19.7	.775	22.3	.877	AB-35/2	AB-35/3	-	-	-
1	13	.095				20.1	.791	22.4	.881	AB-36/2	AB-36/3	-	-	-
1	14	.083	1.1/8	9	.148	20.6	.811	23.1	.909	AB-37/2	AB-37/3	AB-37/4	-	-
1	15 & 16	.072 & .065	1.1/8	10	.134	21.3	.838	23.8	.937	AB-38/2	AB-38/3	AB-38/4	-	-
1	17 & 18	.058 & .048	1.1/8	11	.120	22.0	.866	24.5	.964	AB-39/2	AB-39/3	AB-39/4	-	-
1	19 & 20	.042 & .035	1.1/8	12	.109	22.4	.881	25.0	.984	AB-40/2	AB-40/3	AB-40/4	-	-
1.1/4	8	.165	1.1/8	13	.095	23.3	.917	25.9	1.019	AB-41/2	AB-41/3	AB-41/4	-	-
1.1/4	9	.148	1.1/8	14	.083	23.8	.937	26.5	1.043	AB-42/2	AB-42/3	AB-42/4	-	-
1.1/4	10	.134	1.1/8	15 & 16	.072 & .065	24.4	.960	27.2	1.070	AB-43/2	AB-43/3	AB-43/4	-	-
1.1/4	11	.120				25.2	.992	28.0	1.102	AB-44/2	AB-44/3	AB-44/4	-	-
1.1/4	12	.109				25.7	1.011	28.5	1.122	AB-45/2	AB-45/3	AB-45/4	-	-
1.1/4	13	.095	1.3/8	8	.165	26.1	1.027	28.8	1.133	AB-46/2	AB-46/3	AB-46/4	-	-
1.1/4	14	.083				26.4	1.039	29.2	1.149	AB-47/2	AB-47/3	AB-47/4	-	-
1.1/4	15	.072	1.3/8	9	.148	26.9	1.059	29.7	1.169	AB-48/2	AB-48/3	AB-48/4	-	-
1.1/4	16	.065	1.3/8	10	.134	27.6	1.086	30.4	1.196	AB-49/2	AB-49/3	AB-49/4	AB-49/5	AB-49/6
1.1/2	7	.180	1.3/8	11	.120	28.3	1.114	31.2	1.228	AB-50/2	AB-50/3	AB-50/4	AB-50/5	AB-50/6
1.1/2	8	.165	1.3/8	12	.109	28.8	1.133	31.7	1.248	AB-51/2	AB-51/3	AB-51/4	AB-51/5	AB-51/6
1.1/2	9	.148	1.3/8	13 & 14	.095 & .083	29.5	1.161	33.4	1.314	AB-52/2	AB-52/3	AB-52/4	AB-52/5	AB-52/6
1.1/2	10	.134	1.3/8	15 & 16	.072 & .065	30.0	1.181	34.1	1.342	AB-53/2	AB-53/3	AB-53/4	AB-53/5	AB-53/6
1.1/2	11 & 12	.120 & .109				30.6	1.204	34.8	1.370	AB-54/2	AB-54/3	AB-54/4	AB-54/5	AB-54/6
1.1/2	13	.095	1.3/4	5	.220	31.4	1.236	35.6	1.401	AB-55/2	AB-55/3	AB-55/4	AB-55/5	AB-55/6
1.1/2	14 & 15	.083 & .072	1.3/4	6	.203	32.6	1.283	36.8	1.448	AB-56/2	AB-56/3	AB-56/4	AB-56/5	AB-56/6
			1.3/4	7	.180	33.4	1.314	38.1	1.500	AB-57/2	AB-57/3	AB-57/4	AB-57/5	AB-57/6
			1.3/4	8	.165	34.2	1.346	38.7	1.523	AB-58/2	AB-58/3	AB-58/4	AB-58/5	AB-58/6
2	3	.259	1.3/4	9 & 10	.148 & .134	35.0	1.377	40.6	1.598	AB-59/2	AB-59/3	AB-59/4	AB-59/5	AB-59/6
2	4	.238	1.3/4	11 & 12	.120 & .109	36.6	1.440	42.2	1.661	AB-60/2	AB-60/3	AB-60/4	AB-60/5	AB-60/6
2	5 & 6	.220 & .203	1.3/4	13 & 14	.095 & .083	38.2	1.503	43.8	1.712	AB-61/2	AB-61/3	AB-61/4	AB-61/5	AB-61/6
2	7 & 8	.180 & .165	1.3/4	15 & 16	.072 & .065	39.8	1.566	45.4	1.787	AB-62/2	AB-62/3	AB-62/4	AB-62/5	AB-62/6
2	9 & 10	.148 & .134	2.1/4	3	.259	41.4	1.629	47.0	1.850	AB-63/2	AB-63/3	AB-63/4	AB-63/5	AB-63/6
2	11 - 13	.120 - .095	2.1/4	4	.238	42.9	1.688	49.5	1.948	AB-64/2	AB-64/3	AB-64/4	AB-64/5	AB-64/6
2	14 - 16	.083 - .065	2.1/4	6 & 7	.203 & .180	44.5	1.751	51.1	2.011	AB-65/2	AB-65/3	AB-65/4	AB-65/5	AB-65/6
2	17 & 18	.058 & .049	2.1/4	8 & 9	.165 & .148	46.1	1.814	52.7	2.074	AB-66/2	AB-66/3	AB-66/4	AB-66/5	AB-66/6

# AB SERIES WITH BEARING

$\frac{7}{8}$ "- $4\frac{1}{2}$ "  
O.D.

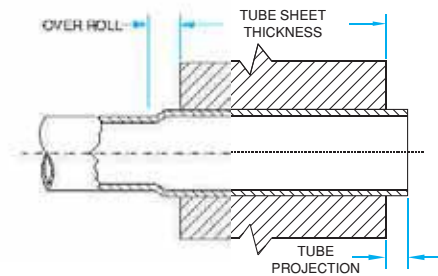

Spare Rollers Set Model Number Tube Sheet Thickness Range					Mandrel Square Drive Size inch	Drum Mandrel Model Number
1/2" To 7/8"	3/4" To 1.1/8"	1.1/8" To 1.5/8"	1.5/8" To 2.1/8"	2.1/8" To 2.5/8"		
15-2-RS	15-3-RS	-	-	-	3/8	DMB-11
15-2-RS	15-3-RS	-	-	-	3/8	DMB-12
16-2-RS	16-3-RS	-	-	-	3/8	DMB-12
20-2-RS	20-3-RS	-	-	-	3/8	DMB-12
17-2-RS	17-3-RS	-	-	-	3/8	DMB-13
18-2-RS	18-3-RS	-	-	-	3/8	DMB-12
18-2-RS	18-3-RS	18-4-RS	-	-	3/8	DMB-13
19-2-RS	19-3-RS	19-4-RS	-	-	3/8	DMB-13
21-2-RS	21-3-RS	21-4-RS	-	-	3/8	DMB-13
21-2-RS	21-3-RS	21-4-RS	-	-	3/8	DMB-14
22-2-RS	22-3-RS	22-4-RS	-	-	3/8	DMB-14
23-2-RS	23-3-RS	23-4-RS	-	-	1/2	DMB-15
24-2-RS	24-3-RS	24-4-RS	-	-	1/2	DMB-15
26-2-RS	26-3-RS	26-4-RS	-	-	1/2	DMB-16
27-2-RS	27-3-RS	27-4-RS	-	-	1/2	DMB-16
31-2-RS	31-3-RS	31-4-RS	-	-	1/2	DMB-16
28-2-RS	28-3-RS	28-4-RS	-	-	1/2	DMB-17
29-2-RS	29-3-RS	29-4-RS	-	-	1/2	DMB-17
30-2-RS	30-3-RS	30-4-RS	30-5-RS	30-6-RS	1/2	DMB-17
30-2-RS	30-3-RS	30-4-RS	30-5-RS	30-6-RS	1/2	DMB-18
32-2-RS	32-3-RS	32-4-RS	32-5-RS	32-6-RS	1/2	DMB-18
28-2-RS	28-3-RS	28-4-RS	28-5-RS	28-6-RS	1/2	DMB-20
29-2-RS	29-3-RS	29-4-RS	29-5-RS	29-6-RS	1/2	DMB-20
30-2-RS	30-3-RS	30-4-RS	30-5-RS	30-6-RS	1/2	DMB-20
33-2-RS	33-3-RS	33-4-RS	33-5-RS	33-6-RS	1/2	DMB-20
32-2-RS	32-3-RS	32-4-RS	32-5-RS	32-6-RS	1/2	DMB-21
36-2-RS	36-3-RS	36-4-RS	36-5-RS	36-6-RS	1/2	DMB-21
37-2-RS	37-3-RS	37-4-RS	37-5-RS	37-6-RS	1/2	DMB-21
33-2-RS	33-3-RS	33-4-RS	33-5-RS	33-6-RS	3/4	DMB-22
37-2-RS	37-3-RS	37-4-RS	37-5-RS	37-6-RS	3/4	DMB-22
38-2-RS	38-3-RS	38-4-RS	38-5-RS	38-6-RS	3/4	DMB-22
39-2-RS	39-3-RS	39-4-RS	39-5-RS	39-6-RS	3/4	DMB-22
40-2-RS	40-3-RS	40-4-RS	40-5-RS	40-6-RS	3/4	DMB-22
40-2-RS	40-3-RS	40-4-RS	40-5-RS	40-6-RS	3/4	DMB-23
41-2-RS	41-3-RS	41-4-RS	41-5-RS	41-6-RS	3/4	DMB-23
42-2-RS	42-3-RS	42-4-RS	42-5-RS	42-6-RS	3/4	DMB-23

7/8" - 4 1/2"  
O.D.

AB SERIES WITH BEARING

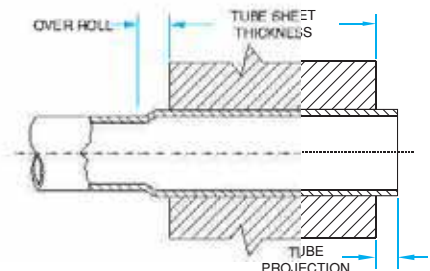

Tube O.D.	Tube Thickness		Tube O.D.	Tube Thickness		Minimum I.D. Tool Enters		Maximum Expansion Of Tool		Tube Expander Model Number Tube Sheet Thickness Range				
	inch	bwg		inch	bwg	inch	mm	inch	mm	inch	1/2" To 7/8"	3/4" To 1.1/8"	1.1/8" To 1.5/8"	1.5/8" To 2.1/8"
2.1/2	3	.259	2.1/4	10 & 11	.134 & .120	47.7	1.877	54.3	2.137	AB-67/2	AB-67/3	AB-67/4	AB-67/5	AB-67/6
2.1/2	4 & 5	.238 & .220	2.1/4	12 & 13	.109 & .095	49.3	1.940	55.9	2.200	AB-68/2	AB-68/3	AB-68/4	AB-68/5	AB-68/6
2.1/2	6 & 7	.203 & .180	2.1/4	14 - 16	.083 - .065	50.8	2.000	57.8	2.275	AB-69/2	AB-69/3	AB-69/4	AB-69/5	AB-69/6
2.1/2	8 & 9	.165 & .148	2.3/4	3	.259	52.4	2.062	59.4	2.338	AB-70/2	AB-70/3	AB-70/4	AB-70/5	AB-70/6
2.1/2	10 & 11	.134 & .120	2.3/4	4	.238	54.0	2.125	61.0	2.401	AB-71/2	AB-71/3	AB-71/4	AB-71/5	AB-71/6
2.1/2	12 - 14	.109 - .083	2.3/4	5 & 6	.220 & .203	55.6	2.188	64.0	2.519	AB-72/2	AB-72/3	AB-72/4	AB-72/5	AB-72/6
2.1/2	15 & 16	.072 & .065	2.3/4	7 & 8	.180 & .165	57.2	2.251	65.6	2.582	AB-73/2	AB-73/3	AB-73/4	AB-73/5	AB-73/6
3	3	.259	2.3/4	9 & 10	.148 & .134	58.6	2.307	67.0	2.637	AB-74/2	AB-74/3	AB-74/4	AB-74/5	AB-74/6
3	4	.238	2.3/4	11 - 13	.120 - .095	60.4	2.377	68.8	2.708	AB-75/2	AB-75/3	AB-75/4	AB-75/5	AB-75/6
3	5 & 6	.220 & .203	2.3/4	14 - 16	.083 - .065	62.2	2.448	70.4	2.771	AB-76/2	AB-76/3	AB-76/4	AB-76/5	AB-76/6
3	7 & 8	.180 & .165				63.6	2.503	72.0	2.834	AB-77/2	AB-77/3	AB-77/4	AB-77/5	AB-77/6
3	9 & 10	.148 & .134	3.1/4	3	.259	65.0	2.559	73.4	2.889	AB-78/2	AB-78/3	AB-78/4	AB-78/5	AB-78/6
3	11 - 13	.120 - .095	3.1/4	4	.238	66.6	2.622	75.0	2.952	AB-79/2	AB-79/3	AB-79/4	AB-79/5	AB-79/6
3	14 - 16	.083 - .065	3.1/4	5 & 6	.220 & .203	68.3	2.688	76.9	3.027	AB-80/2	AB-80/3	AB-80/4	AB-80/5	AB-80/6
3.1/2	2	.284	3.1/4	7 & 8	.180 & .165	69.9	2.751	78.5	3.090	AB-81/2	AB-81/3	AB-81/4	AB-81/5	AB-81/6
3.1/2	3	.259	3.1/4	9 & 10	.148 & .134	71.5	2.814	80.1	3.153	AB-82/2	AB-82/3	AB-82/4	AB-82/5	AB-82/6
3.1/2	4	.238	3.1/4	11 - 13	.120 - .095	73.1	2.877	81.7	3.216	AB-83/2	AB-83/3	AB-83/4	AB-83/5	AB-83/6
3.1/2	5 & 6	.220 & .203	3.1/4	14 - 16	.083 - .065	74.6	2.937	84.2	3.314	AB-84/2	AB-84/3	AB-84/4	AB-84/5	AB-84/6
3.1/2	7 & 8	.180 & .165	3.3/4	2	.284	76.2	3.000	85.5	3.366	AB-85/2	AB-85/3	AB-85/4	AB-85/5	AB-85/6
3.1/2	9 - 11	.148 - .120	3.3/4	3	.259	77.8	3.062	87.4	3.440	AB-86/2	AB-86/3	AB-86/4	AB-86/5	AB-86/6
3.1/2	12 - 16	.109 - .065	3.3/4	4	.238	79.4	3.125	89.0	3.503	AB-87/2	AB-87/3	AB-87/4	AB-87/5	AB-87/6
			3.3/4	5 & 6	.220 & .203	81.0	3.188	90.6	3.566	AB-88/2	AB-88/3	AB-88/4	AB-88/5	AB-88/6
4	2	.284	3.3/4	7 & 8	.180 & .165	82.6	3.251	92.2	3.629	AB-89/2	AB-89/3	AB-89/4	AB-89/5	AB-89/6
4	3	.259	3.3/4	9 & 10	.148 & .134	84.2	3.314	93.8	3.692	AB-90/2	AB-90/3	AB-90/4	AB-90/5	AB-90/6
4	4	.238	3.3/4	11 - 13	.120 - .095	85.8	3.377	96.2	3.787	AB-91/2	AB-91/3	AB-91/4	AB-91/5	AB-91/6
4	5 & 6	.220 & .203	3.3/4	14 - 16	.083 - .065	87.4	3.440	97.8	3.850	AB-92/2	AB-92/3	AB-92/4	AB-92/5	AB-92/6
4	7 & 8	.180 & .165	4.1/4	2	.284	89.0	3.503	99.4	3.913	AB-93/2	AB-93/3	AB-93/4	AB-93/5	AB-93/6
4	9 - 11	.148 - .120	4.1/4	3	.259	90.4	3.559	100.8	3.968	AB-94/2	AB-94/3	AB-94/4	AB-94/5	AB-94/6
4	12 - 16	.109 - .065	4.1/4	4	.238	92.0	3.622	102.4	4.031	AB-95/2	AB-95/3	AB-95/4	AB-95/5	AB-95/6
			4.1/4	5 & 6	.220 & .203	93.4	3.677	103.8	4.086	AB-96/2	AB-96/3	AB-96/4	AB-96/5	AB-96/6
4.1/2	2	.284	4.1/4	7 & 8	.180 & .165	95.0	3.740	105.4	4.149	AB-97/2	AB-97/3	AB-97/4	AB-97/5	AB-97/6
4.1/2	3	.259	4.1/4	9 - 11	.148 - .120	96.6	3.803	107.0	4.212	AB-98/2	AB-98/3	AB-98/4	AB-98/5	AB-98/6
4.1/2	4 & 5	.238 & .220	4.1/4	11 - 13	.120 - .095	98.2	3.866	108.6	4.275	AB-99/2	AB-99/3	AB-99/4	AB-99/5	AB-99/6
4.1/2	6 & 7	.203 & .180				101.2	3.984	110.0	4.330	AB-100/2	AB-100/3	AB-100/4	AB-100/5	AB-100/6
4.1/2	8 & 9	.165 & .148				102.8	4.047	111.6	4.393	AB-101/2	AB-101/3	AB-101/4	AB-101/5	AB-101/6
4.1/2	10 - 12	.134 - .109				104.4	4.110	113.2	4.456	AB-102/2	AB-102/3	AB-102/4	AB-102/5	AB-102/6

# AB SERIES WITH BEARING

7/8" - 4 1/2"  
O.D.

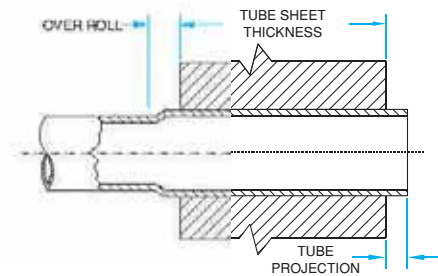

Spare Rollers Set Model Number Tube Sheet Thickness Range					Mandrel Square Drive Size inch	Drum Mandrel Model Number
1/2" To 7/8"	3/4" To 1.1/8"	1.1/8" To 1.5/8"	1.5/8" To 2.1/8"	2.1/8" To 2.5/8"		
43-2-RS	43-3-RS	43-4-RS	43-5-RS	43-6-RS	3/4	DMB-23
44-2-RS	44-3-RS	44-4-RS	44-5-RS	44-6-RS	3/4	DMB-23
43-2-RS	43-3-RS	43-4-RS	43-5-RS	43-6-RS	3/4	DMB-24
44-2-RS	44-3-RS	44-4-RS	44-5-RS	44-6-RS	3/4	DMB-24
45-2-RS	45-3-RS	45-4-RS	45-5-RS	45-6-RS	3/4	DMB-24
47-2-RS	47-3-RS	47-4-RS	47-5-RS	47-6-RS	3/4	DMB-24
46-2-RS	46-3-RS	46-4-RS	46-5-RS	46-6-RS	1	DMB-25
47-2-RS	47-3-RS	47-4-RS	47-5-RS	47-6-RS	1	DMB-25
48-2-RS	48-3-RS	48-4-RS	48-5-RS	48-6-RS	1	DMB-25
49-2-RS	49-3-RS	49-4-RS	49-5-RS	49-6-RS	1	DMB-25
50-2-RS	50-3-RS	50-4-RS	50-5-RS	50-6-RS	1	DMB-25
51-2-RS	51-3-RS	51-4-RS	51-5-RS	51-6-RS	1	DMB-25
52-2-RS	52-3-RS	52-4-RS	52-5-RS	52-6-RS	1	DMB-25
51-2-RS	51-3-RS	51-4-RS	51-5-RS	51-6-RS	1	DMB-26
52-2-RS	52-3-RS	52-4-RS	52-5-RS	52-6-RS	1	DMB-26
53-2-RS	53-3-RS	53-4-RS	53-5-RS	53-6-RS	1	DMB-26
54-2-RS	54-3-RS	54-4-RS	54-5-RS	54-6-RS	1	DMB-26
54-2-RS	54-3-RS	54-4-RS	54-5-RS	54-6-RS	1	DMB-27
55-2-RS	55-3-RS	55-4-RS	55-5-RS	55-6-RS	1	DMB-27
56-2-RS	56-3-RS	56-4-RS	56-5-RS	56-6-RS	1	DMB-27
57-2-RS	57-3-RS	57-4-RS	57-5-RS	57-6-RS	1	DMB-27
58-2-RS	58-3-RS	58-4-RS	58-5-RS	58-6-RS	1	DMB-27
59-2-RS	59-3-RS	59-4-RS	59-5-RS	59-6-RS	1	DMB-27
60-2-RS	60-3-RS	60-4-RS	60-5-RS	60-6-RS	1	DMB-27
59-2-RS	59-3-RS	59-4-RS	59-5-RS	59-6-RS	1	DMB-28
60-2-RS	60-3-RS	60-4-RS	60-5-RS	60-6-RS	1	DMB-28
61-2-RS	61-3-RS	61-4-RS	61-5-RS	61-6-RS	1	DMB-28
62-2-RS	62-3-RS	62-4-RS	62-5-RS	62-6-RS	1	DMB-28
63-2-RS	63-3-RS	63-4-RS	63-5-RS	63-6-RS	1	DMB-28
62-2-RS	62-3-RS	62-4-RS	62-5-RS	62-6-RS	1	DMB-29
63-2-RS	63-3-RS	63-4-RS	63-5-RS	63-6-RS	1	DMB-29
64-2-RS	64-3-RS	64-4-RS	64-5-RS	64-6-RS	1	DMB-29
63-2-RS	63-3-RS	63-4-RS	63-5-RS	63-6-RS	1	DMB-30
64-2-RS	64-3-RS	64-4-RS	64-5-RS	64-6-RS	1	DMB-30
65-2-RS	65-3-RS	65-4-RS	65-5-RS	65-6-RS	1	DMB-30
66-2-RS	66-3-RS	66-4-RS	66-5-RS	66-6-RS	1	DMB-30

AB SERIES WITH BEARING

$\frac{7}{8}$ " -  $4\frac{1}{2}$ "  
O.D.

## ABF3 SERIES WITH BEARING

- Features :**
- Similar to 'AF3' Series expanders (Pg. 68)
  - Bearing reduces frictional buildup for smoother expanding cycles.
  - Bearing increases useful life of tool.
  - Use : High productivity tool used where flaring of tubes is needed.

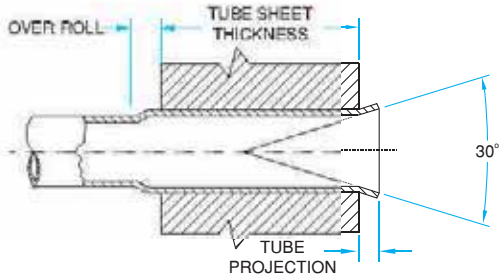

Tube O.D.	Tube Thickness		Tube O.D.	Tube Thickness		Minimum I.D. Tool Enters		Maximum Expansion Of Tool		Tube Expander Model Number Tube Sheet Thickness Range				
	inch	bwg		inch	bwg	inch	mm	inch	mm	inch	1/2" To 7/8"	3/4" To 1.1/8"	1.1/8" To 1.5/8"	1.5/8" To 2.1/8"
7/8	15	.072	1	10	.134	18.1	.712	20.4	.803	ABF3-31/2	ABF3-31/3	-	-	-
7/8	16	.065				18.4	.724	20.7	.814	ABF3-32/2	ABF3-32/3	-	-	-
7/8	17	.058	1	11	.120	18.8	.740	21.1	.830	ABF3-33/2	ABF3-33/3	-	-	-
7/8	18	.049	1	12	.109	19.4	.763	21.6	.850	ABF3-34/2	ABF3-34/3	-	-	-
7/8	19 & 20	.042 & .035	1.1/8	8	.165	19.7	.775	22.3	.877	ABF3-35/2	ABF3-35/3	-	-	-
1	13	.095				20.1	.791	22.4	.881	ABF3-36/2	ABF3-36/3	-	-	-
1	14	.083	1.1/8	9	.148	20.6	.811	23.1	.909	ABF3-37/2	ABF3-37/3	ABF3-37/4	-	-
1	15 & 16	.072 & .065	1.1/8	10	.134	21.3	.838	23.8	.937	ABF3-38/2	ABF3-38/3	ABF3-38/4	-	-
1	17 & 18	.058 & .048	1.1/8	11	.120	22.0	.866	24.5	.964	ABF3-39/2	ABF3-39/3	ABF3-39/4	-	-
1	19 & 20	.042 & .035	1.1/8	12	.109	22.4	.881	25.0	.984	ABF3-40/2	ABF3-40/3	ABF3-40/4	-	-
1.1/4	8	.165	1.1/8	13	.095	23.3	.917	25.9	1.019	ABF3-41/2	ABF3-41/3	ABF3-41/4	-	-
1.1/4	9	.148	1.1/8	14	.083	23.8	.937	26.5	1.043	ABF3-42/2	ABF3-42/3	ABF3-42/4	-	-
1.1/4	10	.134	1.1/8	15 & 16	.072 & .065	24.4	.960	27.2	1.070	ABF3-43/2	ABF3-43/3	ABF3-43/4	-	-
1.1/4	11	.120				25.2	.992	28.0	1.102	ABF3-44/2	ABF3-44/3	ABF3-44/4	-	-
1.1/4	12	.109				25.7	1.011	28.5	1.122	ABF3-45/2	ABF3-45/3	ABF3-45/4	-	-
1.1/4	13	.095	1.3/8	8	.165	26.1	1.027	28.8	1.133	ABF3-46/2	ABF3-46/3	ABF3-46/4	-	-
1.1/4	14	.083				26.4	1.039	29.2	1.149	ABF3-47/2	ABF3-47/3	ABF3-47/4	-	-
1.1/4	15	.072	1.3/8	9	.148	26.9	1.059	29.7	1.169	ABF3-48/2	ABF3-48/3	ABF3-48/4	-	-
1.1/4	16	.065	1.3/8	10	.134	27.6	1.086	30.4	1.196	ABF3-49/2	ABF3-49/3	ABF3-49/4	ABF3-49/5	ABF3-49/6
1.1/2	7	.180	1.3/8	11	.120	28.3	1.114	31.2	1.228	ABF3-50/2	ABF3-50/3	ABF3-50/4	ABF3-50/5	ABF3-50/6
1.1/2	8	.165	1.3/8	12	.109	28.8	1.133	31.7	1.248	ABF3-51/2	ABF3-51/3	ABF3-51/4	ABF3-51/5	ABF3-51/6
1.1/2	9	.148	1.3/8	13 & 14	.095 & .083	29.5	1.161	33.4	1.314	ABF3-52/2	ABF3-52/3	ABF3-52/4	ABF3-52/5	ABF3-52/6
1.1/2	10	.134	1.3/8	15 & 16	.072 & .065	30.0	1.181	34.1	1.342	ABF3-53/2	ABF3-53/3	ABF3-53/4	ABF3-53/5	ABF3-53/6
1.1/2	11 & 12	.120 & .109				30.6	1.204	34.8	1.370	ABF3-54/2	ABF3-54/3	ABF3-54/4	ABF3-54/5	ABF3-54/6
1.1/2	13	.095	1.3/4	5	.220	31.4	1.236	35.6	1.401	ABF3-55/2	ABF3-55/3	ABF3-55/4	ABF3-55/5	ABF3-55/6
1.1/2	14 & 15	.083 & .072	1.3/4	6	.203	32.6	1.283	36.8	1.448	ABF3-56/2	ABF3-56/3	ABF3-56/4	ABF3-56/5	ABF3-56/6
			1.3/4	7	.180	33.4	1.314	38.1	1.500	ABF3-57/2	ABF3-57/3	ABF3-57/4	ABF3-57/5	ABF3-57/6
			1.3/4	8	.165	34.2	1.346	38.7	1.523	ABF3-58/2	ABF3-58/3	ABF3-58/4	ABF3-58/5	ABF3-58/6
2	3	.259	1.3/4	9 & 10	.148 & .134	35.0	1.377	40.6	1.598	ABF3-59/2	ABF3-59/3	ABF3-59/4	ABF3-59/5	ABF3-59/6
2	4	.238	1.3/4	11 & 12	.120 & .109	36.6	1.440	42.2	1.661	ABF3-60/2	ABF3-60/3	ABF3-60/4	ABF3-60/5	ABF3-60/6
2	5 & 6	.220 & .203	1.3/4	13 & 14	.095 & .083	38.2	1.503	43.8	1.712	ABF3-61/2	ABF3-61/3	ABF3-61/4	ABF3-61/5	ABF3-61/6
2	7 & 8	.180 & .165	1.3/4	15 & 16	.072 & .065	39.8	1.566	45.4	1.787	ABF3-62/2	ABF3-62/3	ABF3-62/4	ABF3-62/5	ABF3-62/6
2	9 & 10	.148 & .134	2.1/4	3	.259	41.4	1.629	47.0	1.850	ABF3-63/2	ABF3-63/3	ABF3-63/4	ABF3-63/5	ABF3-63/6
2	11 - 13	.120 - .095	2.1/4	4	.238	42.9	1.688	49.5	1.948	ABF3-64/2	ABF3-64/3	ABF3-64/4	ABF3-64/5	ABF3-64/6
2	14 - 16	.083 - .065	2.1/4	6 & 7	.203 & .180	44.5	1.751	51.1	2.011	ABF3-65/2	ABF3-65/3	ABF3-65/4	ABF3-65/5	ABF3-65/6
2	17 & 18	.058 & .049	2.1/4	8 & 9	.165 & .148	46.1	1.814	52.7	2.074	ABF3-66/2	ABF3-66/3	ABF3-66/4	ABF3-66/5	ABF3-66/6



# ABF3 SERIES WITH BEARING

7/8" - 4 1/2"  
O.D.

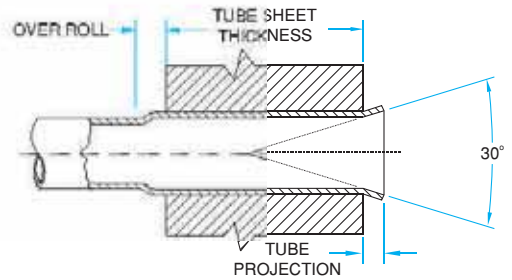

Spare Rollers Set Model Number Tube Sheet Thickness Range					Mandrel Square Drive Size inch	Drum Mandrel Model Number
1/2" To 7/8"	3/4" To 1 1/8"	1 1/8" To 1 5/8"	1 5/8" To 2 1/8"	2 1/8" To 2 5/8"		
15-2-F3S	15-3-F3S	-	-	-	3/8	DMB-11
15-2-F3S	15-3-F3S	-	-	-	3/8	DMB-12
16-2-F3S	16-3-F3S	-	-	-	3/8	DMB-12
20-2-F3S	20-3-F3S	-	-	-	3/8	DMB-12
17-2-F3S	17-3-F3S	-	-	-	3/8	DMB-13
18-2-F3S	18-3-F3S	-	-	-	3/8	DMB-12
18-2-F3S	18-3-F3S	18-4-F3S	-	-	3/8	DMB-13
19-2-F3S	19-3-F3S	19-4-F3S	-	-	3/8	DMB-13
21-2-F3S	21-3-F3S	21-4-F3S	-	-	3/8	DMB-13
21-2-F3S	21-3-F3S	21-4-F3S	-	-	3/8	DMB-14
22-2-F3S	22-3-F3S	22-4-F3S	-	-	3/8	DMB-14
23-2-F3S	23-3-F3S	23-4-F3S	-	-	1/2	DMB-15
24-2-F3S	24-3-F3S	24-4-F3S	-	-	1/2	DMB-15
26-2-F3S	26-3-F3S	26-4-F3S	-	-	1/2	DMB-16
27-2-F3S	27-3-F3S	27-4-F3S	-	-	1/2	DMB-16
31-2-F3S	31-3-F3S	31-4-F3S	-	-	1/2	DMB-16
28-2-F3S	28-3-F3S	28-4-F3S	-	-	1/2	DMB-17
29-2-F3S	29-3-F3S	29-4-F3S	-	-	1/2	DMB-17
30-2-F3S	30-3-F3S	30-4-F3S	30-5-F3S	30-6-F3S	1/2	DMB-17
30-2-F3S	30-3-F3S	30-4-F3S	30-5-F3S	30-6-F3S	1/2	DMB-18
32-2-F3S	32-3-F3S	32-4-F3S	32-5-F3S	32-6-F3S	1/2	DMB-18
28-2-F3S	28-3-F3S	28-4-F3S	28-5-F3S	28-6-F3S	1/2	DMB-20
29-2-F3S	29-3-F3S	29-4-F3S	29-5-F3S	29-6-F3S	1/2	DMB-20
30-2-F3S	30-3-F3S	30-4-F3S	30-5-F3S	30-6-F3S	1/2	DMB-20
33-2-F3S	33-3-F3S	33-4-F3S	33-5-F3S	33-6-F3S	1/2	DMB-20
32-2-F3S	32-3-F3S	32-4-F3S	32-5-F3S	32-6-F3S	1/2	DMB-21
36-2-F3S	36-3-F3S	36-4-F3S	36-5-F3S	36-6-F3S	1/2	DMB-21
37-2-F3S	37-3-F3S	37-4-F3S	37-5-F3S	37-6-F3S	1/2	DMB-21
33-2-F3S	33-3-F3S	33-4-F3S	33-5-F3S	33-6-F3S	3/4	DMB-22
37-2-F3S	37-3-F3S	37-4-F3S	37-5-F3S	37-6-F3S	3/4	DMB-22
38-2-F3S	38-3-F3S	38-4-F3S	38-5-F3S	38-6-F3S	3/4	DMB-22
39-2-F3S	39-3-F3S	39-4-F3S	39-5-F3S	39-6-F3S	3/4	DMB-22
40-2-F3S	40-3-F3S	40-4-F3S	40-5-F3S	40-6-F3S	3/4	DMB-22
40-2-F3S	40-3-F3S	40-4-F3S	40-5-F3S	40-6-F3S	3/4	DMB-23
41-2-F3S	41-3-F3S	41-4-F3S	41-5-F3S	41-6-F3S	3/4	DMB-23
42-2-F3S	42-3-F3S	42-4-F3S	42-5-F3S	42-6-F3S	3/4	DMB-23

ABF3 SERIES WITH BEARING

7/8" - 4 1/2"  
O.D.

ABF3 SERIES WITH BEARING

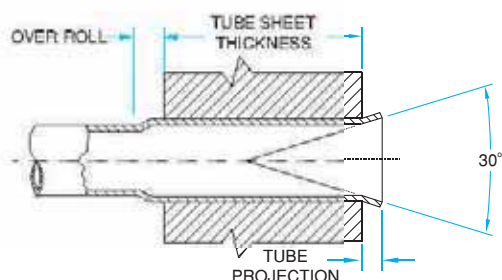

Tube O.D.	Tube Thickness		Tube O.D.	Tube Thickness		Minimum I.D. Tool Enters		Maximum Expansion Of Tool		Tube Expander Model Number Tube Sheet Thickness Range				
	inch	bwg		inch	bwg	inch	mm	inch	mm	inch	1/2" To 7/8"	3/4" To 1.1/8"	1.1/8" To 1.5/8"	1.5/8" To 2.1/8"
2.1/2	3	.259	2.1/4	10 & 11	.134 & .120	47.7	1.877	54.3	2.137	ABF3-67/2	ABF3-67/3	ABF3-67/4	ABF3-67/5	ABF3-67/6
2.1/2	4 & 5	.238 & .220	2.1/4	12 & 13	.109 & .095	49.3	1.940	55.9	2.200	ABF3-68/2	ABF3-68/3	ABF3-68/4	ABF3-68/5	ABF3-68/6
2.1/2	6 & 7	.203 & .180	2.1/4	14 - 16	.083 - .065	50.8	2.000	57.8	2.275	ABF3-69/2	ABF3-69/3	ABF3-69/4	ABF3-69/5	ABF3-69/6
2.1/2	8 & 9	.165 & .148	2.3/4	3	.259	52.4	2.062	59.4	2.338	ABF3-70/2	ABF3-70/3	ABF3-70/4	ABF3-70/5	ABF3-70/6
2.1/2	10 & 11	.134 & .120	2.3/4	4	.238	54.0	2.125	61.0	2.401	ABF3-71/2	ABF3-71/3	ABF3-71/4	ABF3-71/5	ABF3-71/6
2.1/2	12 - 14	.109 - .083	2.3/4	5 & 6	.220 & .203	55.6	2.188	64.0	2.519	ABF3-72/2	ABF3-72/3	ABF3-72/4	ABF3-72/5	ABF3-72/6
2.1/2	15 & 16	.072 & .065	2.3/4	7 & 8	.180 & .165	57.2	2.251	65.6	2.582	ABF3-73/2	ABF3-73/3	ABF3-73/4	ABF3-73/5	ABF3-73/6
3	3	.259	2.3/4	9 & 10	.148 & .134	58.6	2.307	67.0	2.637	ABF3-74/2	ABF3-74/3	ABF3-74/4	ABF3-74/5	ABF3-74/6
3	4	.238	2.3/4	11 - 13	.120 - .095	60.4	2.377	68.8	2.708	ABF3-75/2	ABF3-75/3	ABF3-75/4	ABF3-75/5	ABF3-75/6
3	5 & 6	.220 & .203	2.3/4	14 - 16	.083 - .065	62.2	2.448	70.4	2.771	ABF3-76/2	ABF3-76/3	ABF3-76/4	ABF3-76/5	ABF3-76/6
3	7 & 8	.180 & .165				63.6	2.503	72.0	2.834	ABF3-77/2	ABF3-77/3	ABF3-77/4	ABF3-77/5	ABF3-77/6
3	9 & 10	.148 & .134	3.1/4	3	.259	65.0	2.559	73.4	2.889	ABF3-78/2	ABF3-78/3	ABF3-78/4	ABF3-78/5	ABF3-78/6
3	11 - 13	.120 - .095	3.1/4	4	.238	66.6	2.622	75.0	2.952	ABF3-79/2	ABF3-79/3	ABF3-79/4	ABF3-79/5	ABF3-79/6
3	14 - 16	.083 - .065	3.1/4	5 & 6	.220 & .203	68.3	2.688	76.9	3.027	ABF3-80/2	ABF3-80/3	ABF3-80/4	ABF3-80/5	ABF3-80/6
3.1/2	2	.284	3.1/4	7 & 8	.180 & .165	69.9	2.751	78.5	3.090	ABF3-81/2	ABF3-81/3	ABF3-81/4	ABF3-81/5	ABF3-81/6
3.1/2	3	.259	3.1/4	9 & 10	.148 & .134	71.5	2.814	80.1	3.153	ABF3-82/2	ABF3-82/3	ABF3-82/4	ABF3-82/5	ABF3-82/6
3.1/2	4	.238	3.1/4	11 - 13	.120 - .095	73.1	2.877	81.7	3.216	ABF3-83/2	ABF3-83/3	ABF3-83/4	ABF3-83/5	ABF3-83/6
3.1/2	5 & 6	.220 & .203	3.1/4	14 - 16	.083 - .065	74.6	2.937	84.2	3.314	ABF3-84/2	ABF3-84/3	ABF3-84/4	ABF3-84/5	ABF3-84/6
3.1/2	7 & 8	.180 & .165	3.3/4	2	.284	76.2	3.000	85.5	3.366	ABF3-85/2	ABF3-85/3	ABF3-85/4	ABF3-85/5	ABF3-85/6
3.1/2	9 - 11	.148 - .120	3.3/4	3	.259	77.8	3.062	87.4	3.440	ABF3-86/2	ABF3-86/3	ABF3-86/4	ABF3-86/5	ABF3-86/6
3.1/2	12 - 16	.109 - .065	3.3/4	4	.238	79.4	3.125	89.0	3.503	ABF3-87/2	ABF3-87/3	ABF3-87/4	ABF3-87/5	ABF3-87/6
			3.3/4	5 & 6	.220 & .203	81.0	3.188	90.6	3.566	ABF3-88/2	ABF3-88/3	ABF3-88/4	ABF3-88/5	ABF3-88/6
4	2	.284	3.3/4	7 & 8	.180 & .165	82.6	3.251	92.2	3.629	ABF3-89/2	ABF3-89/3	ABF3-89/4	ABF3-89/5	ABF3-89/6
4	3	.259	3.3/4	9 & 10	.148 & .134	84.2	3.314	93.8	3.692	ABF3-90/2	ABF3-90/3	ABF3-90/4	ABF3-90/5	ABF3-90/6
4	4	.238	3.3/4	11 - 13	.120 - .095	85.8	3.377	96.2	3.787	ABF3-91/2	ABF3-91/3	ABF3-91/4	ABF3-91/5	ABF3-91/6
4	5 & 6	.220 & .203	3.3/4	14 - 16	.083 - .065	87.4	3.440	97.8	3.850	ABF3-92/2	ABF3-92/3	ABF3-92/4	ABF3-92/5	ABF3-92/6
4	7 & 8	.180 & .165	4.1/4	2	.284	89.0	3.503	99.4	3.913	ABF3-93/2	ABF3-93/3	ABF3-93/4	ABF3-93/5	ABF3-93/6
4	9 - 11	.148 - .120	4.1/4	3	.259	90.4	3.559	100.8	3.968	ABF3-94/2	ABF3-94/3	ABF3-94/4	ABF3-94/5	ABF3-94/6
4	12 - 16	.109 - .065	4.1/4	4	.238	92.0	3.622	102.4	4.031	ABF3-95/2	ABF3-95/3	ABF3-95/4	ABF3-95/5	ABF3-95/6
			4.1/4	5 & 6	.220 & .203	93.4	3.677	103.8	4.086	ABF3-96/2	ABF3-96/3	ABF3-96/4	ABF3-96/5	ABF3-96/6
4.1/2	2	.284	4.1/4	7 & 8	.180 & .165	95.0	3.740	105.4	4.149	ABF3-97/2	ABF3-97/3	ABF3-97/4	ABF3-97/5	ABF3-97/6
4.1/2	3	.259	4.1/4	9 - 11	.148 - .120	96.6	3.803	107.0	4.212	ABF3-98/2	ABF3-98/3	ABF3-98/4	ABF3-98/5	ABF3-98/6
4.1/2	4 & 5	.238 & .220	4.1/4	11 - 13	.120 - .095	98.2	3.866	108.6	4.275	ABF3-99/2	ABF3-99/3	ABF3-99/4	ABF3-99/5	ABF3-99/6
4.1/2	6 & 7	.203 & .180				101.2	3.984	110.0	4.330	ABF3-100/2	ABF3-100/3	ABF3-100/4	ABF3-100/5	ABF3-100/6
4.1/2	8 & 9	.165 & .148				102.8	4.047	111.6	4.393	ABF3-101/2	ABF3-101/3	ABF3-101/4	ABF3-101/5	ABF3-101/6
4.1/2	10 - 12	.134 - .109				104.4	4.110	113.2	4.456	ABF3-102/2	ABF3-102/3	ABF3-102/4	ABF3-102/5	ABF3-102/6

# ABF3 SERIES WITH BEARING

$\frac{7}{8}$ "- $4\frac{1}{2}$ "  
O.D.

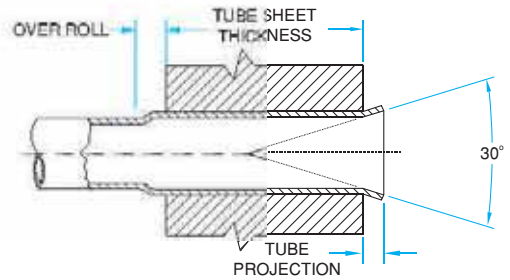

Spare Rollers Set Model Number Tube Sheet Thickness Range					Mandrel Square Drive Size inch	Drum Mandrel Model Number
1/2" To 7/8"	3/4" To 1.1/8"	1.1/8" To 1.5/8"	1.5/8" To 2.1/8"	2.1/8" To 2.5/8"		
43-2-F3S	43-3-F3S	43-4-F3S	43-5-F3S	43-6-F3S	3/4	DMB-23
44-2-F3S	44-3-F3S	44-4-F3S	44-5-F3S	44-6-F3S	3/4	DMB-23
43-2-F3S	43-3-F3S	43-4-F3S	43-5-F3S	43-6-F3S	3/4	DMB-24
44-2-F3S	44-3-F3S	44-4-F3S	44-5-F3S	44-6-F3S	3/4	DMB-24
45-2-F3S	45-3-F3S	45-4-F3S	45-5-F3S	45-6-F3S	3/4	DMB-24
47-2-F3S	47-3-F3S	47-4-F3S	47-5-F3S	47-6-F3S	3/4	DMB-24
46-2-F3S	46-3-F3S	46-4-F3S	46-5-F3S	46-6-F3S	1	DMB-25
47-2-F3S	47-3-F3S	47-4-F3S	47-5-F3S	47-6-F3S	1	DMB-25
48-2-F3S	48-3-F3S	48-4-F3S	48-5-F3S	48-6-F3S	1	DMB-25
49-2-F3S	49-3-F3S	49-4-F3S	49-5-F3S	49-6-F3S	1	DMB-25
50-2-F3S	50-3-F3S	50-4-F3S	50-5-F3S	50-6-F3S	1	DMB-25
51-2-F3S	51-3-F3S	51-4-F3S	51-5-F3S	51-6-F3S	1	DMB-25
52-2-F3S	52-3-F3S	52-4-F3S	52-5-F3S	52-6-F3S	1	DMB-25
51-2-F3S	51-3-F3S	51-4-F3S	51-5-F3S	51-6-F3S	1	DMB-26
52-2-F3S	52-3-F3S	52-4-F3S	52-5-F3S	52-6-F3S	1	DMB-26
53-2-F3S	53-3-F3S	53-4-F3S	53-5-F3S	53-6-F3S	1	DMB-26
54-2-F3S	54-3-F3S	54-4-F3S	54-5-F3S	54-6-F3S	1	DMB-26
54-2-F3S	54-3-F3S	54-4-F3S	54-5-F3S	54-6-F3S	1	DMB-27
55-2-F3S	55-3-F3S	55-4-F3S	55-5-F3S	55-6-F3S	1	DMB-27
56-2-F3S	56-3-F3S	56-4-F3S	56-5-F3S	56-6-F3S	1	DMB-27
57-2-F3S	57-3-F3S	57-4-F3S	57-5-F3S	57-6-F3S	1	DMB-27
58-2-F3S	58-3-F3S	58-4-F3S	58-5-F3S	58-6-F3S	1	DMB-27
59-2-F3S	59-3-F3S	59-4-F3S	59-5-F3S	59-6-F3S	1	DMB-27
60-2-F3S	60-3-F3S	60-4-F3S	60-5-F3S	60-6-F3S	1	DMB-27
59-2-F3S	59-3-F3S	59-4-F3S	59-5-F3S	59-6-F3S	1	DMB-28
60-2-F3S	60-3-F3S	60-4-F3S	60-5-F3S	60-6-F3S	1	DMB-28
61-2-F3S	61-3-F3S	61-4-F3S	61-5-F3S	61-6-F3S	1	DMB-28
62-2-F3S	62-3-F3S	62-4-F3S	62-5-F3S	62-6-F3S	1	DMB-28
63-2-F3S	63-3-F3S	63-4-F3S	63-5-F3S	63-6-F3S	1	DMB-28
62-2-F3S	62-3-F3S	62-4-F3S	62-5-F3S	62-6-F3S	1	DMB-29
63-2-F3S	63-3-F3S	63-4-F3S	63-5-F3S	63-6-F3S	1	DMB-29
64-2-F3S	64-3-F3S	64-4-F3S	64-5-F3S	64-6-F3S	1	DMB-29
63-2-F3S	63-3-F3S	63-4-F3S	63-5-F3S	63-6-F3S	1	DMB-30
64-2-F3S	64-3-F3S	64-4-F3S	64-5-F3S	64-6-F3S	1	DMB-30
65-2-F3S	65-3-F3S	65-4-F3S	65-5-F3S	65-6-F3S	1	DMB-30
66-2-F3S	66-3-F3S	66-4-F3S	66-5-F3S	66-6-F3S	1	DMB-30

ABF3 SERIES WITH BEARING



P-1000 SERIES

- Features :**
- Overlapping rolls prevent ridging of tube.
  - Use - Ideal for use in limited access space like water boxes, small diameter drums.

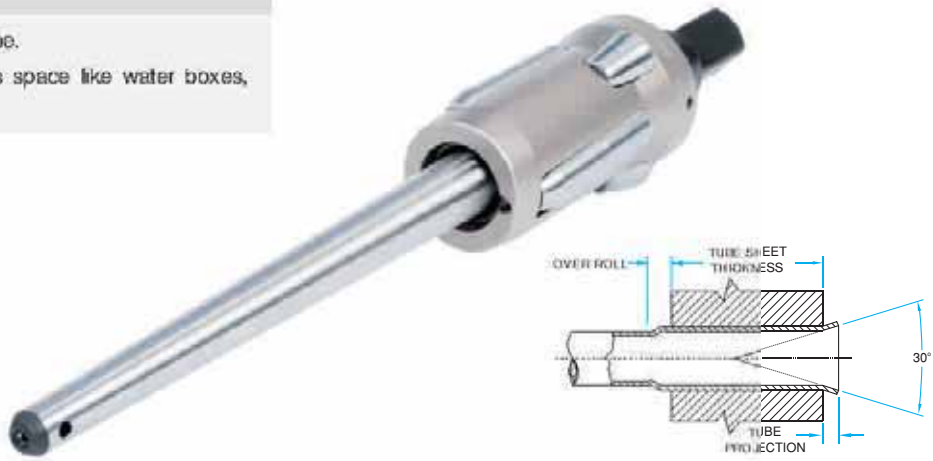

Tube O.D.	Tube Thickness		Tube O.D.	Tube Thickness		Minimum I.D. Tool Enters		Maximum Expansion Of Tool		Tube Expander Model Number Tube Sheet Thickness Range				
	inch	bwg		inch	bwg	inch	mm	inch	mm	inch	1/2" To 3/4"	7/8" To 1.1/4"	1.3/8" To 1.3/4"	1.7/8" To 2.1/4"
1	13 & 14	.095 & .083	1.1/8	9	.148	19.7	.775	23.4	.921	P1079/3	P1079/5	-	-	-
1	15 & 16	.072 & .065	1.1/8	10	.134	20.7	.814	24.4	.961	P1083/3	P1083/5	-	-	-
1.1/4	7	.180	1.1/8	11 & 12	.120 & .109	21.7	.854	25.5	1.004	P1087/3	P1087/5	-	-	-
1.1/4	8 & 9	.165 & .148	1.1/8	13 & 14	.095 & .083	22.7	.893	26.5	1.043	P1091/3	P1091/5	-	-	-
1.1/4	10	.134	1.1/8	15 & 16	.072 & .065	23.7	.933	28.1	1.105	P1095/3	P1095/5	-	-	-
1.1/4	11 - 13	.120 - .095	1.3/8	8	.165	24.7	.972	29.0	1.142	P1099/3	P1099/5	-	-	-
1.1/4	14 & 15	.083 & .072	1.3/8	9	.148	25.7	1.011	30.0	1.181	P1103/3	P1103/5	-	-	-
1.1/4	16	.065	1.3/8	10	.134	27.8	1.094	33.0	1.299	P1111/3	P1111/5	-	-	-
1.1/2	10 - 12	.134 - .109	1.3/8	15 & 16	.072 & .065	30.7	1.208	35.0	1.378	P1118/3	P1118/5	-	-	-
1.1/2	13 - 16	.095 - .065	1.3/4	6 & 7	.203 & .180	32.7	1.287	38.0	1.496	P1126/3	P1126/5	-	-	-
2	3	.259	1.3/4	8 & 9	.165 & .148	34.7	1.366	40.0	1.575	P1134/3	P1134/5	P1134/7	P1134/9	P1134/11
2	4 & 5	.238 & .220	1.3/4	10 - 12	.134 - .109	36.7	1.444	42.5	1.673	P1142/3	P1142/5	P1142/7	P1142/9	P1142/11
2	6	.203	1.3/4	13 - 16	.096 - .065	38.7	1.523	44.5	1.752	P1150/3	P1150/5	P1150/7	P1150/9	P1150/11
2	7 - 9	.180 - .148	2.1/4	3	.259	40.7	1.602	47.0	1.850	P1158/3	P1158/5	P1158/7	P1158/9	P1158/11
2	10 - 12	.134 - .109	2.1/4	4	.238	42.7	1.681	49.0	1.929	P1166/3	P1166/5	P1166/7	P1166/9	P1166/11
2	13 - 15	.095 - .072	2.1/4	5 & 6	.220 & .203	44.7	1.760	51.5	2.027	P1174/3	P1174/5	P1174/7	P1174/9	P1174/11
2	16	.065	2.1/4	7 - 9	.180 - .148	46.7	1.838	54.0	2.126	P1181/3	P1181/5	P1181/7	P1181/9	P1181/11
2.1/2	4 & 5	.238 & .220	2.1/4	10 - 13	.134 - .095	48.7	1.917	56.0	2.205	P1189/3	P1189/5	P1189/7	P1189/9	P1189/11
2.1/2	6	.203	2.1/4	14 - 16	.083 - .065	50.7	1.996	60.0	2.362	P1197/3	P1197/5	P1197/7	P1197/9	P1197/11
2.1/2	7 - 10	.180 - .134	2.3/4	2 & 3	.284 & .259	52.7	2.074	62.0	2.441	P1205/3	P1205/5	P1205/7	P1205/9	P1205/11
2.1/2	11 - 13	.120 - .095	2.3/4	4 & 5	.238 & .220	54.7	2.153	64.0	2.520	P1213/3	P1213/5	P1213/7	P1213/9	P1213/11
2.1/2	14 - 16	.083 - .065	2.3/4	6 - 8	.203 - .165	56.7	2.232	66.0	2.598	P1221/3	P1221/5	P1221/7	P1221/9	P1221/11
3	2	.284	2.3/4	7 - 9	.180 - .148	58.7	2.311	68.0	2.677	P1229/3	P1229/5	P1229/7	P1229/9	P1229/11
3	3 & 4	.259 & .238	2.3/4	10 - 12	.134 - .109	60.7	2.389	70.0	2.756	P1237/3	P1237/5	P1237/7	P1237/9	P1237/11
3	5 & 6	.220 & .203	2.3/4	13 - 16	.095 - .065	62.7	2.468	72.0	2.835	P1244/3	P1244/5	P1244/7	P1244/9	P1244/11
3	7 & 8	.180 & .165				64.7	2.547	74.0	2.913	P1252/3	P1252/5	P1252/7	P1252/9	P1252/11
3	10 - 12	.134 - .109	3.1/4	3	.259	66.7	2.625	76.0	2.992	P1260/3	P1260/5	P1260/7	P1260/9	P1260/11
3	13 & 14	.095 & .083	3.1/4	4	.238	68.7	2.704	78.0	3.071	P1268/3	P1268/5	P1268/7	P1268/9	P1268/11
3	15 & 16	.072 & .065	3.1/4	5 & 6	.220 & .203	70.7	2.783	80.0	3.150	P1276/3	P1276/5	P1276/7	P1276/9	P1276/11
3.1/2	2 & 3	.284 & .259	3.1/4	7 - 11	.180 - .120	72.7	2.862	82.0	3.228	P1284/3	P1284/5	P1284/7	P1284/9	P1284/11
3.1/2	4 - 6	.259 - .203	3.1/4	12 - 14	.109 - .480	74.7	2.940	84.0	3.307	P1292/3	P1292/5	P1292/7	P1292/9	P1292/11
3.1/2	7 - 9	.180 - .148	3.1/4	15 & 16	.072 & .065	76.7	3.019	86.0	3.386	P1300/3	P1300/5	P1300/7	P1300/9	P1300/11
3.1/2	10 - 12	.134 - .109	3.3/4	2 & 3	.284 & .259	78.7	3.098	88.0	3.465	P1308/3	P1308/5	P1308/7	P1308/9	P1308/11
3.1/2	13 - 15	.095 - .072	3.3/4	4 - 6	.259 - .203	80.7	3.177	92.0	3.622	P1315/3	P1315/5	P1315/7	P1315/9	P1315/11
3.1/2	16	.065	3.3/4	7 & 8	.180 & .165	82.7	3.255	94.0	3.701	P1323/3	P1323/5	P1323/7	P1323/9	P1323/11
4	3	.259	3.3/4	9 - 12	.148 - .109	84.7	3.334	96.0	3.780	P1331/3	P1331/5	P1331/7	P1331/9	P1331/11
4	4 - 6	.259 - .203	3.3/4	13 - 16	.095 - .065	86.7	3.413	98.0	3.858	P1339/3	P1339/5	P1339/7	P1339/9	P1339/11
4	7 & 8	.180 & .165	4.1/4	2	.284	88.7	3.492	100.0	3.937	P1347/3	P1347/5	P1347/7	P1347/9	P1347/11
4	9 - 12	.148 - .109	4.1/4	3	.259	90.7	3.570	102.0	4.016	P1355/3	P1355/5	P1355/7	P1355/9	P1355/11
4	13 - 15	.095 - .072	4.1/4	4	.238	92.7	3.649	104.0	4.094	P1363/3	P1363/5	P1363/7	P1363/9	P1363/11
4	16	.065	4.1/4	7 & 8	.180 & .165	94.7	3.728	106.0	4.173	P1370/3	P1370/5	P1370/7	P1370/9	P1370/11
4.1/2	3	.259	4.1/4	9 - 11	.148 - .120	96.7	3.807	108.0	4.252	P1378/3	P1378/5	P1378/7	P1378/9	P1378/11
4.1/2	4 - 6	.259 - .203	4.1/4	12 - 16	.109 - .065	98.7	3.885	110.0	4.331	P1386/3	P1386/5	P1386/7	P1386/9	P1386/11
4.1/2	7 - 14	.180 - .083				100.7	3.964	111.0	4.407	P1394/3	P1394/5	P1394/7	P1394/9	P1394/11

# P-1000 SERIES

1" - 4 1/2"  
O.D.

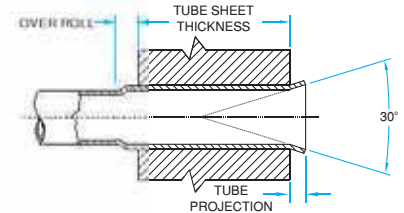

Spare Rollers Set Model Number Tube Sheet Thickness Range					Mandrel Square Drive Size inch	Spare Mandrel Model Number	
1/2" To 3/4"	7/8" To 1.1/4"	1.3/8" To 1.3/4"	1.7/8" To 2.1/4"	2.3/8" To 2.3/4"		Drum Type	Short Series Mandrels
079-3-FS	079-5-FS	-	-	-	1/2	83-MP	-
083-3-FS	083-5-FS	-	-	-	1/2	83-MP	-
087-3-FS	087-5-FS	-	-	-	1/2	91-MP	-
095-3-FS	095-5-FS	-	-	-	1/2	91-MP	-
095-3-FS	095-5-FS	-	-	-	1/2	99-MP	-
099-3-FS	099-5-FS	-	-	-	1/2	99-MP	-
103-3-FS	103-5-FS	-	-	-	1/2	99-MP	-
111-3-FS	111-5-FS	-	-	-	3/4	118-MP	MPS-1,2,3
118-3-FS	118-5-FS	-	-	-	3/4	118-MP	MPS-1,2,3
126-3-FS	126-5-FS	-	-	-	3/4	126-MP	MPS-2,3,4
126-3-FS	126-5-FS	126-7-FS	126-9-FS	126-11-FS	3/4	134-MP	MPS-3,4,5
142-3-FS	142-5-FS	142-7-FS	142-9-FS	142-11-FS	3/4	150-MP	MPS-3,4,5,6
150-3-FS	150-5-FS	150-7-FS	150-9-FS	150-11-FS	3/4	150-MP	MPS-3,4,5,6
158-3-FS	158-5-FS	158-7-FS	158-9-FS	158-11-FS	3/4	174-MP	MPS-4,5,6,7,8
166-3-FS	166-5-FS	166-7-FS	166-9-FS	166-11-FS	3/4	174-MP	MPS-4,5,6,7,8
174-3-FS	174-5-FS	174-7-FS	174-9-FS	174-11-FS	3/4	174-MP	MPS-4,5,6,7,8
181-3-FS	181-5-FS	181-7-FS	181-9-FS	181-11-FS	1	197-MP	MPS-7,8,9,10,11
174-3-FS	174-5-FS	174-7-FS	174-9-FS	174-11-FS	1	197-MP	MPS-7,8,9,10,11
205-3-FS	205-5-FS	205-7-FS	205-9-FS	205-11-FS	1	197-MP	MPS-6,7,8,9,10,11
205-3-FS	205-5-FS	205-7-FS	205-9-FS	205-11-FS	1	221-MP	MPS-7,8,9,10,11,12
213-3-FS	213-5-FS	213-7-FS	213-9-FS	213-11-FS	1	221-MP	MPS-7,8,9,10,11,12
221-3-FS	221-5-FS	221-7-FS	221-9-FS	221-11-FS	1	221-MP	MPS-7,8,9,10,11,12
221-3-FS	221-5-FS	221-7-FS	221-9-FS	221-11-FS	1	244-MP	MPS-8,9,10,11,12,13
237-3-FS	237-5-FS	237-7-FS	237-9-FS	237-11-FS	1	244-MP	MPS-8,9,10,11,12,13
252-3-FS	252-5-FS	252-7-FS	252-9-FS	252-11-FS	1	244-MP	MPS-8,9,10,11,12,13
252-3-FS	252-5-FS	252-7-FS	252-9-FS	252-11-FS	1	268-MP	MPS-10,11,12,13,14
260-3-FS	260-5-FS	260-7-FS	260-9-FS	260-11-FS	1	268-MP	MPS-10,11,12,13,14
268-3-FS	268-5-FS	268-7-FS	268-9-FS	268-11-FS	1	268-MP	MPS-10,11,12,13,14
276-3-FS	276-5-FS	276-7-FS	276-9-FS	276-11-FS	1	300-MP	MPS-12,13,14,15,16
284-3-FS	284-5-FS	284-7-FS	284-9-FS	284-11-FS	1	300-MP	MPS-12,13,14,15,16
292-3-FS	292-5-FS	292-7-FS	292-9-FS	292-11-FS	1	300-MP	MPS-12,13,14,15,16
315-3-FS	315-5-FS	315-7-FS	315-9-FS	315-11-FS	1	300-MP	MPS-12,13,14,15,16
284-3-FS	284-5-FS	284-7-FS	284-9-FS	284-11-FS	1	347-MP	MPS-15,16,17,18,19
315-3-FS	315-5-FS	315-7-FS	315-9-FS	315-11-FS	1	347-MP	MPS-14,15,16,17,18,19
323-3-FS	323-5-FS	323-7-FS	323-9-FS	323-11-FS	1	347-MP	MPS-14,15,16,17,18,19
331-3-FS	331-5-FS	331-7-FS	331-9-FS	331-11-FS	1	347-MP	MPS-14,15,16,17,18,19
355-3-FS	355-5-FS	355-7-FS	355-9-FS	355-11-FS	1	347-MP	MPS-14,15,16,17,18,19
363-3-FS	363-5-FS	363-7-FS	363-9-FS	363-11-FS	1	347-MP	MPS-14,15,16,17,18,19
355-3-FS	355-5-FS	355-7-FS	355-9-FS	355-11-FS	1	394-MP	MPS-17,18,19,20,21
363-3-FS	363-5-FS	363-7-FS	363-9-FS	363-11-FS	1	394-MP	MPS-17,18,19,20,21
370-3-FS	370-5-FS	370-7-FS	370-9-FS	370-11-FS	1	394-MP	MPS-17,18,19,20,21
378-3-FS	378-5-FS	378-7-FS	378-9-FS	378-11-FS	1	394-MP	MPS-17,18,19,20,21
386-3-FS	386-5-FS	386-7-FS	386-9-FS	386-11-FS	1	394-MP	MPS-17,18,19,20,21
394-3-FS	394-5-FS	394-7-FS	394-9-FS	394-11-FS	1	394-MP	MPS-17,18,19,20,21

1/4" - 4 1/2"  
O.D.

P-3000 SERIES WITH COLLAR

- Features :*
- Expander can be accurately positioned in the boiler tube in relation to the drum, for consistent expansions.
  - Use - For boiler tube sheets and drums thicker than 2.3/4" (70mm). Normally used in conjunction with P-1000 Series.

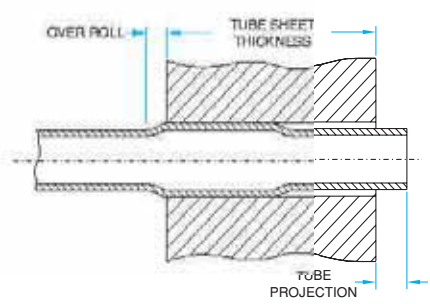

Tube O.D.	Tube Thickness		Tube O.D.	Tube Thickness		Minimum I.D. Tool Enters		Maximum Expansion Of Tool		Tube Expander Model Number Tube Sheet Thickness Range	
	inch	bwg		inch	bwg	inch	mm	inch	mm	inch	1/2" To 4.3/8"
1.1/4	16	.065	1.3/8	10	.134	27.8	1.094	33.0	1.299	P3111/7	-
1.1/2	10 - 12	.134 - .109	1.3/8	13 - 16	.095 - .065	30.7	1.208	35.0	1.378	P3118/7	-
1.1/2	13 - 16	.095 - .065	1.3/4	5 - 7	.220 - .180	32.7	1.287	38.0	1.496	P3126/7	-
2	3	.259	1.3/4	8 & 9	.165 & .148	34.7	1.366	40.0	1.575	P3134/7	P3134/11
2	4 & 5	.238 & .220	1.3/4	10 - 12	.134 - .109	36.7	1.444	42.5	1.673	P3142/7	P3142/11
2	6	.203	1.3/4	13 - 16	.095 - .065	38.7	1.523	44.5	1.752	P3150/7	P3150/11
2	7 - 9	.180 - .148	2.1/4	3	.259	40.7	1.602	47.0	1.850	P3158/7	P3158/11
2	10 - 12	.134 - .109	2.1/4	4 & 5	.238 & .220	42.7	1.681	49.0	1.929	P3166/7	P3166/11
2	13 - 15	.095 - .072	2.1/4	6 & 7	.203 & .180	44.7	1.760	51.5	2.027	P3174/7	P3174/11
2	16	.065	2.1/4	8 & 9	.165 & .148	46.7	1.838	54.0	2.126	P3181/7	P3181/11
2.1/2	4 & 5	.238 - .220	2.1/4	10 - 13	.134 - .095	48.7	1.917	65.0	2.205	P3189/7	P3189/11
2.1/2	6	.203	2.1/4	14 - 6	.083 - .065	50.7	1.996	60.0	2.362	P3197/7	P3197/11
2.1/2	7 - 10	.180 - .134	2.3/4	3	.259	52.7	2.074	62.0	2.441	P3205/7	P3205/11
2.1/2	11 - 13	.120 - .095	2.3/4	4 & 5	.238 & .220	54.7	2.153	64.0	2.520	P3213/7	P3213/11
2.1/2	14 - 16	.083 - .065	2.3/4	6	.203	56.7	2.232	66.0	2.598	P3221/7	P3221/11
3	2 & 3	.284 & .259	2.3/4	7 - 9	.203 - .148	58.7	2.311	68.0	2.677	P3229/7	P3229/11
3	4	.238	2.3/4	10 - 12	.134 - .109	60.7	2.389	70.0	2.756	P3237/7	P3237/11
3	5 & 6	.220 - .203	2.3/4	13 - 16	.095 - .065	62.7	2.468	72.0	2.835	P3244/7	P3244/11
3	7 - 9	.180 - .148	3.1/4	2 & 3	.284 & .259	64.7	2.547	74.0	2.913	P3252/7	P3252/11
3	10 - 12	.134 - .109	3.1/4	4	.238	66.7	2.625	76.0	2.992	P3260/7	P3260/11
3	13 - 14	.095 - .083	3.1/4	5	.220	68.7	2.704	78.0	3.071	P3268/7	P3268/11
3	15 & 16	.072 & .065	3.1/4	6	.203	70.7	2.783	80.0	3.150	P3276/7	P3276/11
3.1/2	3 & 4	.284 & .238	3.1/4	7 - 11	.203 - .120	72.7	2.862	82.0	3.228	P3284/7	P3284/11
3.1/2	5 & 6	.220 & .203	3.1/4	12 - 14	.109 - .083	74.7	2.940	84.0	3.307	P3292/7	P3292/11
3.1/2	7 - 9	.180 - .148	3.1/8	15 & 16	.072 & .065	76.7	3.019	86.0	3.386	P3300/7	P3300/11
3.1/2	10 - 12	.134 - .109	3.1/4	3 & 4	.284 & .238	78.7	3.098	88.0	3.465	P3308/7	P3308/11
3.1/2	13 - 15	.095 - .072	3.3/4	5 & 6	.220 & .203	80.7	3.177	92.0	3.622	P3315/7	P3315/11
3.1/2	16	.065	3.3/4	7 & 8	.203 & .165	82.7	3.255	94.0	3.701	P3323/7	P3323/11
4	3 & 4	.284 & .238	3.3/4	9 - 12	.148 - .109	84.7	3.334	96.0	3.780	P3331/7	P3331/11
4	5 & 6	.220 & .203	3.3/4	13 - 16	.095 - .065	86.7	3.413	98.0	3.858	P3339/7	P3339/11
4	7 & 8	.180 & .165	4.1/4	2	.284	88.7	3.492	100.0	3.937	P3347/7	P3347/11
4	9 - 12	.148 - .109	4.1/4	3 & 4	.284 & .238	90.7	3.570	102.0	4.016	P3355/7	P3355/11
4	13 - 15	.095 - .072	4.1/4	5 & 6	.220 & .203	92.7	3.649	104.0	4.094	P3363/7	P3363/11
4	16	.065	4.1/4	7 & 8	.203 & .165	94.7	3.728	106.0	4.173	P3370/7	P3370/11
4.1/2	3	.284	4.1/4	9 - 11	.148 - .120	96.7	3.807	108.0	4.252	P3378/7	P3378/11
4.1/2	4 - 6	.238 - .203	4.1/4	12 - 16	.109 - .065	98.7	3.885	110.0	4.331	P3386/7	P3386/11
4.1/2	7 - 14	.180 - .083				100.7	3.964	111.0	4.407	P3394/7	P3394/11

# P-3000 SERIES WITH COLLAR

1/4" - 1/2"  
O.D.

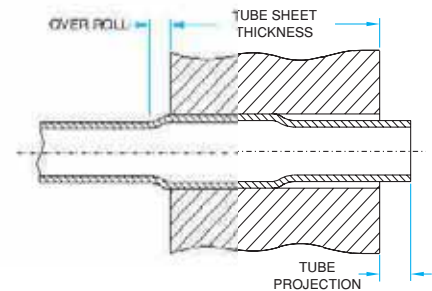

Spare Rollers Set Model Number Tube Sheet Thickness Range		Mandrel Square Drive Size inch	Spare Mandrel Model Number	
1/2" To 4.3/8"	1.1/2" To 5.3/8"		Drum Type	Short Series Mandrels
111-7-RS	-	3/4	118-M	MS-1,2,3
118-7-RS	-	3/4	118-M	MS-1,2,3
126-7-RS	-	3/4	126-M	MS-2,3,4
126-7-RS	126-11-RS	3/4	134-M	MS-3,4,5
142-7-RS	142-11-RS	3/4	150-M	MS-3,4,5,6
150-7-RS	150-11-RS	3/4	150-M	MS-3,4,5,6
158-7-RS	158-11-RS	3/4	174-M	MS-4,5,6,7,8
166-7-RS	166-11-RS	3/4	174-M	MS-4,5,6,7,8
174-7-RS	174-11-RS	3/4	174-M	MS-4,5,6,7,8
181-7-RS	181-11-RS	1	197-M	MS-7,8,9,10,11,12
174-7-RS	174-11-RS	1	197-M	MS-7,8,9,10,11,12
205-7-RS	205-11-RS	1	197-M	MS-6,7,8,9,10,11,12
205-7-RS	205-11-RS	1	221-M	MS-7,8,9,10,11,12
213-7-RS	213-11-RS	1	221-M	MS-7,8,9,10,11,12
221-7-RS	221-11-RS	1	221-M	MS-7,8,9,10,11,12
221-7-RS	221-11-RS	1	244-M	MS-8,9,10,11,12,13
237-7-RS	237-11-RS	1	244-M	MS-8,9,10,11,12,13
252-7-RS	252-11-RS	1	244-M	MS-8,9,10,11,12,13
252-7-RS	252-11-RS	1	268-M	MS-10,11,12,13,14
260-7-RS	260-11-RS	1	268-M	MS-10,11,12,13,14
268-7-RS	268-11-RS	1	268-M	MS-10,11,12,13,14
276-7-RS	276-11-RS	1	300-M	MS-12,13,14,15,16
284-7-RS	284-11-RS	1	300-M	MS-12,13,14,15,16
292-7-RS	292-11-RS	1	300-M	MS-12,13,14,15,16
315-7-RS	315-11-RS	1	300-M	MS-12,13,14,15,16
284-7-RS	284-11-RS	1	347-M	MS-15,16,17,18,19
315-7-RS	315-11-RS	1	347-M	MS-14,15,16,17,18,19
323-7-RS	323-11-RS	1	347-M	MS-14,15,16,17,18,19
331-7-RS	331-11-RS	1	347-M	MS-14,15,16,17,18,19
355-7-RS	355-11-RS	1	347-M	MS-14,15,16,17,18,19
363-7-RS	363-11-RS	1	347-M	MS-14,15,16,17,18,19
355-7-RS	355-11-RS	1	394-M	MS-17,18,19,20,21
363-7-RS	363-11-RS	1	394-M	MS-17,18,19,20,21
370-7-RS	370-11-RS	1	394-M	MS-17,18,19,20,21
378-7-RS	378-11-RS	1	394-M	MS-17,18,19,20,21
386-7-RS	386-11-RS	1	394-M	MS-17,18,19,20,21
394-7-RS	394-11-RS	1	394-M	MS-17,18,19,20,21

2"-3"  
O.D.

## COMBINATION BEADING EXPANDERS

### TUBE EXPANDING AND BEADING IN SINGLE OPERATION

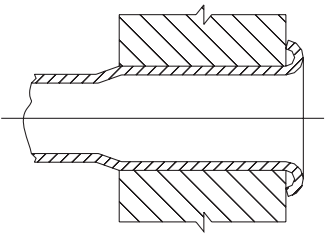

	Previously	Now
Tools Required	1) Flaring tube expander 2) Tube expander drive 3) Beading tool 4) Air hammer	1) COMBINATION BEADING EXPANDER 2) Tube Expander Drive
Operating Steps	1) Expand 2) Bead 3) Reroll	1) Expand and Bead (single operation)
Operator Fatigue	high...largely due to air hammer vibration and noise	Reduced significantly no air hammer for beading ... no rerolling

Tube O.D. inch	Tube Thickness		Expansion Range		Model No.	Mandrel Model No. (Square)	Spare Roller Set Model No.	Beading Roll Model No.	Guide Roll Assembly Model No.
	bwg	inch	mm	inch					
2	10	.134	43.2 - 48.41	1.700 - 1.906	41633 - 0010	41615 (3/4")	41670 set of 4	41631 - 0010	41701 - 0010
	11	.120			41633 - 0011			41631 - 0011	41701 - 0011
	12	.109			41633 - 0012			41631 - 0012	41701 - 0012
	13	.095			41633 - 0013			41631 - 0013	41701 - 0013
2.1/2	10	.134	55.9 - 62.48	2.200 - 2.460	41634 - 0010	41635 (1")	41673 set of 5	41651 - 0010	41702 - 0010
	11	.120			41634 - 0011			41651 - 0011	41702 - 0011
	12	.109			41634 - 0012			41651 - 0012	41702 - 0012
	13	.095			41634 - 0013			41651 - 0013	41702 - 0013
3	10	.134	68.6 - 75.69	2.700 - 2.980	41359 - 0010	41653 (1")	41676 set of 5	41666 - 0010	41703 - 0010
	11	.120			41359 - 0011			41666 - 0011	41703 - 0011
	12	.109			41359 - 0012			41666 - 0012	41703 - 0012

**Note :** Refer to operation manual for other spare parts. Reverse mandrels are available.

1"-3"  
O.D.

## V SERIES NON PARALLEL EXPANSION

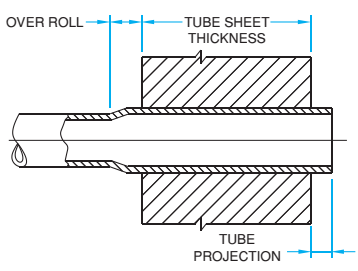

• Use : Type 'V' Expander is used for repair and erection of boilers having thin tube sheets. It is approximately twice as fast during use than other conventional expanders. Use Header Mandrel when expander is to be used through a waterleg.

Tube O.D. inch	Tube Thickness		Expansion Range		Effective Rolling Length		Tube Expander Model No.	Spare Mandrel			Spare Roller Set Model No.
	bwg	inch	Dim.A - Dim.B mm	Dim.A - Dim.B inch	mm	inch		Short Mandrel Model No.	Header Mandrel Model No.	Mandrel Sq. Size inch	
1	10 - 13	.134 - .095	17.3 - 23.7	.681 - .937	84.20	3.5/16	V - 1	VSM - 1	VHM - 1	1/2	VR - 1
1.1/4	10 - 13	.134 - .095	23.8 - 30.6	.940 - 1.206	84.20	3.5/16	V - 2	VSM - 2	VHM - 2	1/2	VR - 2
1.1/2	10 - 13	.134 - .095	29.3 - 37.3	1.156 - 1.469	101.20	4.000	V - 3	VSM - 3	VHM - 3	1/2	VR - 3
2	10 - 13	.134 - .095	42.3 - 49.7	1.665 - 1.960	101.20	4.000	V - 4	VSM - 4	VHM - 4	3/4	VR - 4
2.1/2	10 - 13	.134 - .095	54.5 - 62.7	2.145 - 2.469	101.20	4.000	V - 5	VSM - 5	VHM - 5	3/4	VR - 5
3	10 - 13	.134 - .095	68.2 - 76.6	2.687 - 3.015	101.20	4.000	V - 6	VSM - 6	VHM - 6	1	VR - 6

**Note :** Other sizes available on request.



# SB SERIES FOR SUGAR MILLS

1 1/2" - 4 1/2"  
O.D.

## Features :

- '5 Roll' design is used primarily for rolling thin walled tubes used in sugar mill juice heaters, pans.
- '5 Rolls' give you a more concentric, uniform expansion vs. a '3 roll' expander in thin tubes and reduces tube 'spring back' effect.
- Use - For top plate tube expansion in pans, juice heaters in sugar mills.



SB SERIES

①

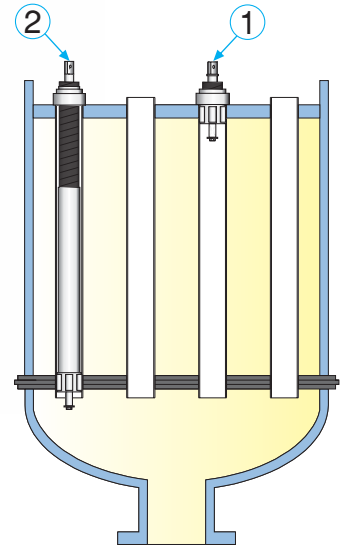

Tube O.D.	Tube Thickness		Minimum I.D. Tool Enters		Maximum Expansion Of Tool		Tube Sheet Thickness mm (inch)			Spare Mandrel Model No.	Mandrel Sq. Drive Inch	Spare Rollers Set Model No.		
	inch	bwg	inch	mm	inch	mm	inch	31.75 (1.25)	38.1 (1.5)			50.8 (2.0)	Tube Expander Model No.	
1.1/2	11 & 12	.120 & .109	31.0	1.220	33.2	1.307	SB-00A	SB-00B	SB-00C	SBM-1	1/2	SBR-1A	SBR-1B	SBR-1C
1.1/2	13 & 14	.095 & .083	32.5	1.279	36.0	1.417	SB-0A	SB-0B	SB-0C	SBM-2	1/2	SBR-2A	SBR-2B	SBR-2C
1.1/2	15 & 16	.072 & .065	33.5	1.319	37.2	1.465	SB-1A	SB-1B	SB-1C	SBM-2	1/2	SBR-3A	SBR-3B	SBR-3C
1.3/4	9 & 10	.148 & .134	35.2	1.386	39.1	1.539	SB-2A	SB-2B	SB-2C	SBM-3	3/4	SBR-3A	SBR-3B	SBR-3C
1.3/4	11 & 12	.120 & .109	36.5	1.437	40.5	1.594	SB-3A	SB-3B	SB-3C	SBM-3	3/4	SBR-4A	SBR-4B	SBR-4C
1.3/4	13 & 14	.095 & .083	38.1	1.500	42.7	1.681	SB-4A	SB-4B	SB-4C	SBM-3	3/4	SBR-5A	SBR-5B	SBR-5C
1.3/4	15 & 16	.072 & .065	39.1	1.539	44.2	1.740	SB-5A	SB-5B	SB-5C	SBM-4	3/4	SBR-4A	SBR-4B	SBR-4C
2	7 & 8	.180 & .165	41.3	1.626	46.7	1.838	SB-6A	SB-6B	SB-6C	SBM-4	3/4	SBR-5A	SBR-5B	SBR-5C
2	9 & 10	.148 & .134	42.8	1.685	48.3	1.901	SB-7A	SB-7B	SB-7C	SBM-4	3/4	SBR-6A	SBR-6B	SBR-6C
2	11 - 13	.120 - .095	44.4	1.748	49.7	1.957	SB-8A	SB-8B	SB-8C	SBM-5	3/4	SBR-6A	SBR-6B	SBR-6C
2	14 - 16	.083 - .065	46.0	1.811	52.2	2.055	SB-9A	SB-9B	SB-9C	SBM-5	3/4	SBR-7A	SBR-7B	SBR-7C
2.1/4	9 & 10	.148 & .134	47.6	1.874	53.8	2.118	SB-10A	SB-10B	SB-10C	SBM-5	3/4	SBR-8A	SBR-8B	SBR-8C
2.1/4	11 - 13	.120 - .095	49.2	1.937	55.4	2.181	SB-11A	SB-11B	SB-11C	SBM-5	3/4	SBR-9A	SBR-9B	SBR-9C
2.1/4	14 - 16	.083 - .065	50.7	1.996	57.8	2.275	SB-12A	SB-12B	SB-12C	SBM-6	3/4	SBR-8A	SBR-8B	SBR-8C
2.1/2	9 & 10	.148 & .134	54.9	2.161	61.0	2.401	SB-13A	SB-13B	SB-13C	SBM-6	3/4	SBR-10A	SBR-10B	SBR-10C
2.1/2	14 - 16	.083 - .065	57.1	2.248	65.6	2.582	SB-14A	SB-14B	SB-14C	SBM-7	1	SBR-11A	SBR-11B	SBR-11C
2.3/4	10 - 14	.134 - .083	60.3	2.374	68.8	2.708	SB-15A	SB-15B	SB-15C	SBM-7	1	SBR-12A	SBR-12B	SBR-12C
3	7 - 9	.180 - .148	63.5	2.500	72.0	2.835	SB-16A	SB-16B	SB-16C	SBM-7	1	SBR-13A	SBR-13B	SBR-13C
3	10 - 14	.134 - .083	66.5	2.618	75.0	2.953	SB-17A	SB-17B	SB-17C	SBM-7	1	SBR-14A	SBR-14B	SBR-14C
3.1/4	7 & 8	.180 & .165	69.8	2.748	78.5	3.090	SB-18A	SB-18B	SB-18C	SBM-8	1	SBR-14A	SBR-14B	SBR-14C
3.1/2	4 & 5	.238 & .220	73.0	2.874	81.7	3.216	SB-19A	SB-19B	SB-19C	SBM-8	1	SBR-15A	SBR-15B	SBR-15C
3.1/2	6 - 8	.203 - .165	76.1	2.996	85.8	3.378	SB-20A	SB-20B	SB-20C	SBM-9	1	SBR-16A	SBR-16B	SBR-16C
3.3/4	4 & 5	.238 & .220	79.3	3.122	89.0	3.504	SB-21A	SB-21B	SB-21C	SBM-9	1	SBR-17A	SBR-17B	SBR-17C
3.3/4	6 - 8	.203 - .165	82.5	3.248	92.2	3.629	SB-22A	SB-22B	SB-22C	SBM-9	1	SBR-18A	SBR-18B	SBR-18C
4	3 & 4	.259 & .238	85.7	3.374	96.2	3.787	SB-23A	SB-23B	SB-23C	SBM-10	1	SBR-18A	SBR-18B	SBR-18C
4	10 - 16	.134 - .065	90.3	3.555	100.8	3.968	SB-24A	SB-24B	SB-24C	SBM-10	1	SBR-19A	SBR-19B	SBR-19C
4.1/4	6 - 8	.203 - .165	94.9	3.736	105.2	4.141	SB-25A	SB-25B	SB-25C	SBM-11	1	SBR-20A	SBR-20B	SBR-20C
4.1/2	4 - 7	.238 - .180	89.7	3.531	110.9	4.366	SB-26A	SB-26B	SB-26C	SBM-11	1	SBR-21A	SBR-21B	SBR-21C
4.1/2	8 - 10	.165 - .134	104.3	4.106	113.1	4.452	SB-27A	SB-27B	SB-27C	SBM-12	1	SBR-21A	SBR-21B	SBR-21C

1 3/4" - 4"  
O.D.

**LONG REACH CSB SERIES**

- Features :*
- '5 Roll' design is used primarily for rolling thin walled tubes used in sugar mill juice heaters, pans.
  - '5 Rolls' give you a more concentric, uniform expansion vs. a '3 roll' expander in thin tubes and reduces tube 'spring back' effect.
  - Use - For bottom plate tube expansion in pans, juice heaters in sugar mills.

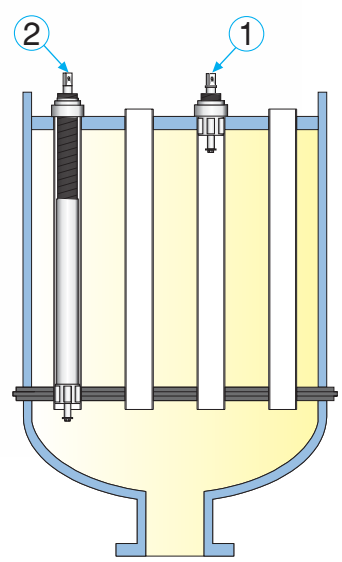

Tube O.D.	Tube Thickness		Minimum I.D. Tool Enters		Maximum Expansion Of Tool		Tube Sheet Thickness 'T'		Depth in Mtrs.		Mandrel Sq. Size	Oal	Weight in Kgs.	Tube Expander Model No.	Spare Mandrel Model No.	Spare Rollers Set Model No.
	inch	bwg	inch	mm	inch	mm	inch	mm	inch	min						
<b>CSB-5 (3 Rollers)</b>																
1.3/4	15 & 16	.072 & .065	39.8	1.566	45.3	1.783	32.0	1.259	1.7	2.0	3/4	2.258	10.0	CSB-5STD	CSBM-5STD	CSBR-5
1.3/4	15 & 16	.072 & .065	39.8	1.566	45.3	1.783	32.0	1.259	2.0	2.3	3/4	2.558	11.2	CSB-5A	CSBM-5A	CSBR-5
1.3/4	15 & 16	.072 & .065	39.8	1.566	45.3	1.783	32.0	1.259	2.3	2.3	3/4	2.858	12.4	CSB-5B	CSBM-5B	CSBR-5
1.3/4	15 & 16	.072 & .065	39.8	1.566	45.3	1.783	32.0	1.259	2.6	2.9	3/4	3.158	13.7	CSB-5C	CSBM-5C	CSBR-5
1.3/4	15 & 16	.072 & .065	39.8	1.566	45.3	1.783	32.0	1.259	2.9	3.2	3/4	3.458	14.9	CSB-5D	CSBM-5D	CSBR-5
1.3/4	15 & 16	.072 & .065	39.8	1.566	45.3	1.783	32.0	1.259	3.2	3.5	3/4	3.758	16.2	CSB-5E	CSBM-5E	CSBR-5
<b>CSB-9 (5 Rollers)</b>																
2	14 - 16	.083 - .065	46.2	1.818	50.8	2.000	32.0	1.259	1.7	2.0	3/4	2.241	16.2	CSB-9STD	CSBM-9STD	CSBR-9
2	14 - 16	.083 - .065	46.2	1.818	50.8	2.000	32.0	1.259	2.0	2.3	3/4	2.541	18.3	CSB-9A	CSBM-9A	CSBR-9
2	14 - 16	.083 - .065	46.2	1.818	50.8	2.000	32.0	1.259	2.3	2.3	3/4	2.841	20.4	CSB-9B	CSBM-9B	CSBR-9
2	14 - 16	.083 - .065	46.2	1.818	50.8	2.000	32.0	1.259	2.6	2.9	3/4	3.141	22.5	CSB-9C	CSBM-9C	CSBR-9
2	14 - 16	.083 - .065	46.2	1.818	50.8	2.000	32.0	1.259	2.9	3.2	3/4	3.441	24.6	CSB-9D	CSBM-9D	CSBR-9
2	14 - 16	.083 - .065	46.2	1.818	50.8	2.000	32.0	1.259	3.2	3.5	3/4	3.741	26.7	CSB-9E	CSBM-9E	CSBR-9
<b>CSB-24 (5 Rollers)</b>																
4	12 - 18	.109 - .049	90.5	3.563	102.4	4.031	32.0	1.259	0.7	1.0	1	1.416	23.7	CSB-24STD	CSBM-24STD	CSBR-24
4	12 - 18	.109 - .049	90.5	3.563	102.4	4.031	32.0	1.259	1.0	1.3	1	1.716	29.4	CSB-24A	CSBM-24A	CSBR-24
4	12 - 18	.109 - .049	90.5	3.563	102.4	4.031	32.0	1.259	1.3	1.6	1	2.016	35.5	CSB-24B	CSBM-24B	CSBR-24
4	12 - 18	.109 - .049	90.5	3.563	102.4	4.031	32.0	1.259	1.6	1.9	1	2.316	40.8	CSB-24C	CSBM-24C	CSBR-24
4	12 - 18	.109 - .049	90.5	3.563	102.4	4.031	32.0	1.259	1.9	2.2	1	2.616	46.5	CSB-24D	CSBM-24D	CSBR-24
4	12 - 18	.109 - .049	90.5	3.563	102.4	4.031	32.0	1.259	2.2	2.5	1	2.916	52.5	CSB-24E	CSBM-24E	CSBR-24

**Note :** Other sizes, special lengths are available on request.

## Taper Shank - Interchangeable Female Square

Morse Taper No.	Square Size	Model No.	Insert Square Size	Insert Model No.
2	3/8"	MM/2/95	3/8"	MDT/95
	1/2"	MM/2/127	1/2"	MDT/127
3	3/8"	MM/3/95	3/8"	MDT/95
	1/2"	MM/3/127	1/2"	MDT/127
	3/4"	MM/3/190	3/4"	MDT/190
	1"	MM/3/254	1"	MDT/254
4	3/8"	MM/4/95	3/8"	MDT/95
	1/2"	MM/4/127	1/2"	MDT/127
	3/4"	MM/4/190	3/4"	MDT/190
	1"	MM/4/254	1"	MDT/254
5	3/8"	MM/5/95	3/8"	MDT/95
	1/2"	MM/5/127	1/2"	MDT/127
	3/4"	MM/5/190	3/4"	MDT/190
	1"	MM/5/254	1"	MDT/254



Use - Mandrel drives serve the purpose of adapting tube expander mandrels to existing air or electric drills. Loosening the knurled nut, releases the square insert type of socket for the introduction of another size of insert to couple to other size of mandrel square.

## Taper Shank - Male Square



Morse Taper No.	Square Size	Model No.
1	3/8"	MTM/1/95
	1/2"	MTM/1/127
2	3/8"	MTM/2/95
	1/2"	MTM/2/127
3	3/4"	MTM/3/190
	1"	MTM/3/254
4	3/4"	MTM/4/190
	1"	MTM/4/254

## Taper Shank - Female Square



Morse Taper No.	Square Size	Model No.
1	3/8"	MTF/1/95
	1/2"	MTF/1/127
2	3/8"	MTF/2/95
	1/2"	MTF/2/127
3	3/4"	MTF/3/190
	1"	MTF/3/254
4	3/4"	MTF/4/190
	1"	MTF/4/254

## Triangle Shank - Female Square



Square Size	Chuck Size	Model No.
3/8"	1/4"	MTC/95/63
3/8"	3/8"	MTC/95/95
3/8"	1/2"	MTC/95/127
1/2"	1/2"	MTC/127/127

## Reversible Ratchet Wrench



Square Size	Length	Model No.
3/8"	8"	HR/95
1/2"	10"	HR/127
3/4"	20"	HR/195
1"	24"	HR/254

**Note :** Ratchets are also available with hexagonal female openings for driving one revolution tube cutters and other items.

## ACCESSORIES

### Male x Male Drive Extensions



Square Sizes	Model No.	OAL	Dia.
3/8"	EB/95/6	6"	1/2"
	EB/95/9	9"	
	EB/95/12	12"	
	EB/95/18	18"	
1/2"	EB/127/6	6"	5/8"
	EB/127/9	9"	
	EB/127/12	12"	
	EB/127/18	18"	
	EB/127/24	24"	
3/4"	EB/195/6	6"	1"
	EB/195/9	9"	
	EB/195/12	12"	
	EB/195/18	18"	
	EB/195/24	24"	
1"	EB/254/6	6"	1.1/4"
	EB/254/12	12"	
	EB/254/14	14"	
	EB/254/18	18"	
	EB/254/24	24"	

### Female x Female Extension Couplings



Square Sizes	Model No.	OAL	Dia.
3/8" x 3/8"	EC/95/95	1.7/16"	13/16"
3/8" x 1/2"	EC/95/127	1.9/16"	1.1/16"
3/8" x 5/8"	EC/95/158	1.1/2"	1.1/4"
1/2" x 1/2"	EC/127/127	1.11/16"	1.1/16"
1/2" x 5/8"	EC/127/158	1.5/8"	1.1/4"
1/2" x 3/4"	EC/127/195	1.5/8"	1.3/8"
1/2" x 7/8"	EC/127/222	1.5/8"	1.5/8"
1/2" x 1"	EC/127/254	1.5/8"	1.7/8"
5/8" x 3/4"	EC/158/195	1.9/16"	1.3/8"
5/8" x 7/8"	EC/158/222	2"	1.5/8"
5/8" x 1"	EC/158/254	1.13/16"	1.7/8"
3/4" x 3/4"	EC/195/195	1.5/8"	1.7/16"
3/4" x 7/8"	EC/195/222	1.5/8"	1.3/4"
3/4" x 1"	EC/195/254	1.13/16"	1.7/8"
7/8" x 7/8"	EC/222/222	1.11/16"	1.3/4"
7/8" x 1"	EC/222/254	2.1/8"	2.1/8"
1" x 1"	EC/254/254	2.1/16"	1.7/8"

## UNIVERSAL JOINTS

### Universal Joint Female-Female

Square Sizes	Model No.	OAL	Major Dia.
3/8"	UJ/95	2.1/4"	7/8"
1/2"	UJ/127	2.5/8"	1"
3/4"	UJ/195	3"	1.1/2"
1"	UJ/254	3.3/4"	1.3/4"



### Universal Joint Male-Female

Square Sizes	Model No.	OAL	Major Dia.
3/8"	UC/95	2.1/4"	7/8"
1/2"	UC/127	2.19/32"	1"
3/4"	UC/195	3.9/32"	1.1/2"
1"	UC/254	4"	1.3/4"



### Double Universal Joint Female-Female

Square Sizes	Model No.	OAL	Major Dia.
3/8"	DUJ/95	3.15/16"	1.1/8"
1/2"	DUJ/127	4"	1.5/16"
3/4"	DUJ/195	4.11/16"	1.5/8"
1"	DUJ/254	6.1/32"	2.1/4"



# UNIVERSAL JOINTS

## Extension Universal Joint Female - Male



Square Size Female	Square Size Male	Model No.	OAL	Major Dia.	Square Size Female	Square Size Male	Model No.	OAL	Major Dia.
3/8"	3/8"	UE/95/6	6"	1.1/8"	3/4"	3/4"	UE/195/9	9"	1.3/4"
		UE/95/9	9"				UE/195/12	12"	
		UE/95/12	12"				UE/195/16	16"	
3/8"	1/2"	UE/95S/9	9"	UE/195/20			20"		
		UE/95S/12	12"	UE/254/9			9"	2.1/4"	
		UE/95S/16	16"				UE/254/12		
1/2"	1/2"	UE/127/6	6"	UE/254/16	16"				
		UE/127/9	9"						
		UE/127/12	12"						
		UE/127/16	16"						
		UE/127/20	20"						

# GEAR DRIVES

## Parallel Gear Train Drive



Square Size	Number of Openings	Model No.	Replacement Parts				Dimensions	
			Double Hub Gear		Center Gear		OAL	Width (W)
			Model No.	Nos. Reqd.	Model No.	Nos. Reqd.		
3/8"	3	BG/3/95	BGH/3/95	3	BGC/3/95	4	8.1/2"	2"
1/2"	3	BG/3/127	BGH/3/127	3	BGC/3/127	4	8.1/2"	2"
	4	BG/4/127	BGH/4/127	4	BGC/4/127	3		
3/4"	3	BG/3/195	BGH/3/195	3	BGC/3/195	4	9"	2.1/2"
	4	BG/4/195	BGH/4/195	4	BGC/4/195	3		
1"	4	BG/4/254	BGH/4/254	4	BGC/4/254	3	9"	2.1/2"

## Right Angle Worm Gear Drive

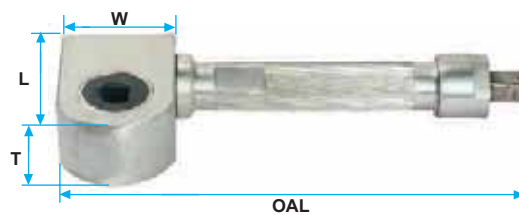

Male Square	Female Square	Model No.	OAL	Gear Housing			Minimum Hand Hole Diameter	Gear Ratio
				Length (L)	Width (W)	Thick (T)		
1/2"	1/2"	RW/127/127	10.3/16"	3.3/16"	2.1/4"	1.3/8"	3.3/8"	4.1/2 to 1
1/2"	3/4"	RW/127/195	10.3/16"	3.3/16"	2.1/4"	1.3/8"	3.3/8"	4.1/2 to 1
3/4"	3/4"	RW/195/195	11.9/32"	3.27/32"	2.5/8"	1.7/8"	4"	4.1/2 to 1
3/4"	1"	RW/195/254	11.9/32"	4.1/4"	3.1/16"	1.7/8"	4.1/2"	4.1/2 to 1

## BOILER TUBE EXPANDING ACCESSORIES

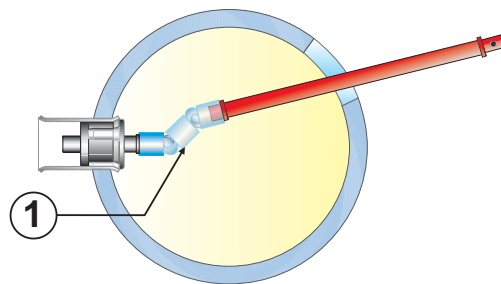

**1) Universal Joints** - Female x Female are most common and are used to create flexibility in reaching hard to get to spots.

**Double Universal Joints** - Allow more deflection than Female x Female universal joints.

**Male x Male** - are suitable for use in super heater headers.

**2) Extension Universal Joint** - Integral design eliminates coupling an extension with a universal joint and are used when expanding tubes through water wall headers, super heater headers, water legs etc.

**3) Extension Couplings** - Are available in plain or reducing type and are used to connect drive extensions, mandrels, and universal joints.

**4) Right Angle Worm Gear Drive** - Used for Operating in very confined areas of boiler headers. Has a one piece construction for maximum life.

**5) Drive Extensions** - Are used with universal joints and parallel gear train drives as well as extension couplings for extending expander mandrel reach through water legs, headers etc.

**6) Parallel Gear Train Drive** - Have high strength gears with bronze bushings to expand tubes in hard to reach places.

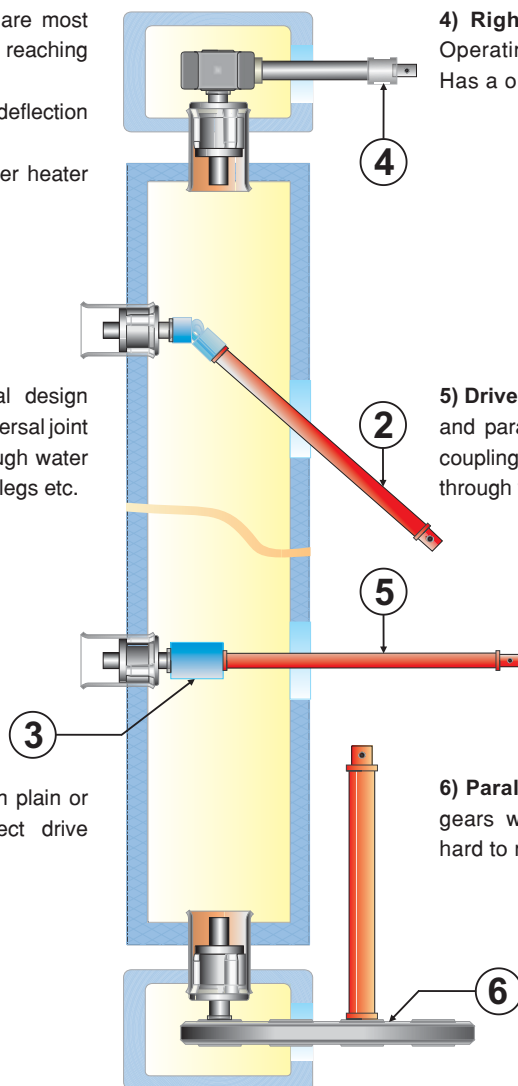

## LUBE-A-TUBE

For expander rolling tube ends into tube sheets.

**Application :** Apply directly to the inside of the tube ends by hand.

**Removal :** Any excess of Lube-A-Tube is removed by wiping or the residue will be completely removed during hydrotest / boil-out operations.

### Features :

- Being a soft, paste lubricant, Tube-A-Tube is easy to apply and “stays put” in the tube prior to the actual rolling operation - it will not run like oil.
- No chance of entering between the tube sheet and tube end OD.
- Will not carbonize under the heat and pressure encountered during the tube rolling operation.
- Lube-A-Tube is its own indicator serving to show the operator what tubes are still to be expanded, eliminating the possibility of missed tubes.
- Lube-A-Tube keeps the expanding tool cool and prolongs tool life.
- Equally effective for rolling condenser tubes, boiler tubes and heavy wall cracking still tubes in refining equipment.



Sold in 100 ml tubes or 2 kg cans.



# TUBE CLEANERS

Page 93-116



1/4" & UP  
I.D.

**ELECTRIC TUBE CLEANERS**

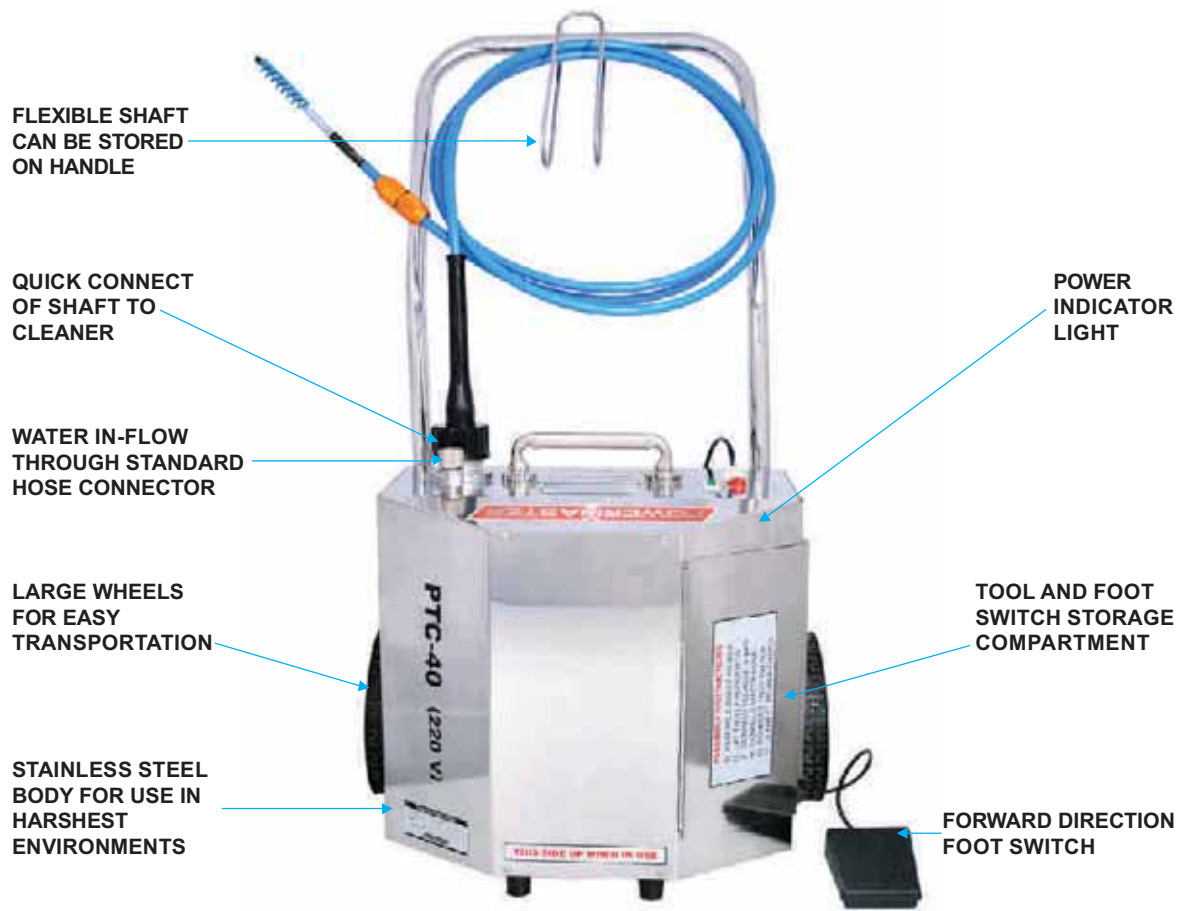

FLEXIBLE SHAFT CAN BE STORED ON HANDLE

QUICK CONNECT OF SHAFT TO CLEANER

WATER IN-FLOW THROUGH STANDARD HOSE CONNECTOR

LARGE WHEELS FOR EASY TRANSPORTATION

STAINLESS STEEL BODY FOR USE IN HARSH ENVIRONMENTS

POWER INDICATOR LIGHT

TOOL AND FOOT SWITCH STORAGE COMPARTMENT

FORWARD DIRECTION FOOT SWITCH

*Features :*

- Water flushes through the shaft and helps remove deposits from tube.
- Forward direction foot switch enables operator to concentrate on cleaning operation without worrying about cleaner.
- Flexible shaft can be easily disconnected.
- Stainless steel body for use in the harshest environments.
- Easy interchangeability of various shafts and accessories for maximum versatility.
- Large wheels for easy transportation.
- Water consumption can be regulated as needed.

Electric Tube Cleaners are environment friendly, compact and easily maneuverable units used to clean straight and curved tubes in heat exchangers, condensers, boilers and other tubular apparatus. They work by attaching a cleaning tool (to be determined on type of deposit to be cleaned) to a flexible shaft. The Electric Tube Cleaner provides rotary motion to the flexible shaft which rotates the cleaning tool inside the tube. If needed water passes through the flexible shaft to aid in flushing out of the deposits. All Electric Tube Cleaners are supplied with forward direction foot switch. Dual direction foot switches are available on request.

Tube I.D.		Tube Cleaner Model No.	Motor Power		Motor Speed RPM	Weight		Dimension		
mm	inch		HP	kW		lbs.	Kg.	High	Wide	Deep
6.4-25.4	1/4-1	PTC-40	1/2	0.40	890	62	28	38"(975mm)	21"(535mm)	18"(457mm)
6.4-25.4	1/4-1	PTC-60	3/4	0.60	890	66	30	38"(975mm)	21"(535mm)	18"(457mm)
25.4 & UP	1 & UP	PTC-75	1	0.75	1780	70	32	38"(975mm)	21"(535mm)	18"(457mm)
25.4 & UP	1 & UP	PTC-150	2	1.50	1780	84	38	40"(1015mm)	22"(560mm)	19"(482mm)

All units available in your choice of :  
 110v 60Hz, 110v 50Hz - 9 Amps.  
 220v 60Hz, 220v 50Hz - 4.5 Amps.  
 Please Specify when ordering.



# PNEUMATIC TUBE CLEANERS

1/4" & UP  
I.D.

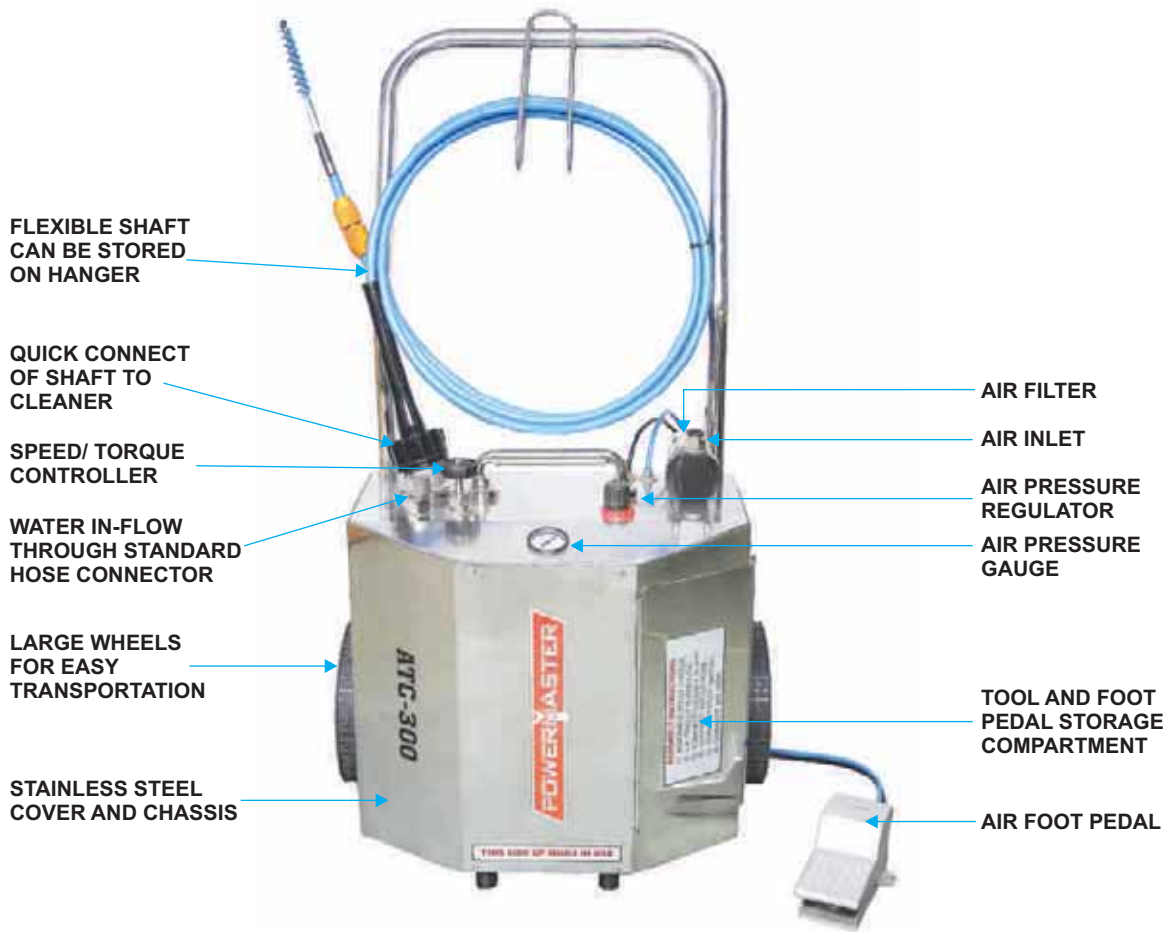

## Features :

- Shock Resistant - Excellent for applications where using electric equipment is hazardous.
- Corrosion Resistant - Stainless steel cover and chassis for long life.
- Versatile - Interchangeability of different size flexible shafts and cleaning tools.
- Speed/Torque control - Shaft rotation can be set at optimum speed for each application.
- No Tooling - Quick disconnect of flexible shaft.
- Easy Maneuverability - Large Wheels.
- Time Saving - Simultaneous water flush to remove deposits from tubes.
- Cleanliness - Foot pedal for operator convenience to activate shaft rotation and water flow to reduced water consumption and cleaner working area.

Powermaster Model ATC-300 Extra Heavy Duty Pneumatic Tube Cleaning Machine includes air filter, regulator, lubricator, adjustable speed/torque control, mobile dolly, tool storage box and air foot pedal.

The ATC-300 uses a cleaning tool mounted to the tip of a flexible shaft, which is available in different lengths and diameters to fit the size of the tube to be cleaned. For wet applications as the shaft rotates inside its watertight nylon casing, the unit feeds water through the casing to the cleaning tool. A foot pedal controls shaft rotation and water flow. While the operator feeds the rotating shaft assembly through the tube, the water flushes out deposits as they are loosened.

Tube I.D.		Tube Cleaner Model No.	Motor Power		Motor Speed RPM	Weight		High	Dimension	
mm	inch		HP	KW		lbs.	Kg.		Wide	Deep
6.4 & UP	1/4 & UP	ATC-300	4	3.00	300-3000	64	29	38"(975mm)	22"(560mm)	16"(406mm)



**ELECTRIC TUBE CLEANING SYSTEMS**

**MODEL TCS-40 CHILLER TUBE CLEANING SYSTEM**

**MODEL TCS-40** Chiller Tube Cleaning System is the most common package used for cleaning 5/8" I.D. tubes of Trane, Blue Star, Thermax, Carrier, York, and other units.

- CONTENTS**
- PTC - 40 Tube Cleaner - 1 no.
  - PFS - 500-79 Flexible Shafts - 2 nos.
  - Nylon Brushes (specify size) - 25 nos.
  - PBT-1, 2, 3 or 4 Buffing tools (specify size) - 2 nos.
  - Replacement blades for Buffing Tools - 8 nos.
  - Repair kit for flexible shaft PFS-500 consisting of 4 drive end couplings, 4 tool end couplings, 1 shaft repair tool with hammer, 1 flexible shaft lubricator and 2 bottles of lubricant.



**PTC-40 TUBE CLEANER**



**FLEXIBLE SHAFT**



**NYLON BRUSH**



**BUFFING TOOL**



**REPLACEMENT BLADES**



**SHAFT REPAIR TOOL**



**REPAIR KIT**

**MODEL TCS-60 CHILLER TUBE CLEANING SYSTEM**

**MODEL TCS-60** Chiller Tube Cleaning System is similar to the TCS-40 Tube Cleaning System, but uses a more powerful 3/4 HP motor for tougher deposits. A dual direction foot switch is provided for cleaning internally grooved tubes.

- CONTENTS**
- PTC - 60 Tube Cleaner - 1 nos.
  - PFS - 500 - 140 Flexible Shafts - 2 nos.
  - Nylon Brush (specify size) - 25 nos.
  - Repair kit for flexible shaft PFS - 500 consisting of 4 drive end couplings, 4 tool end couplings, 1 shaft repair tool with hammer, 1 flexible shaft lubricator and 2 bottles of lubricant.



**PTC-60 TUBE CLEANER**



**FLEXIBLE SHAFT**



**NYLON BRUSH**



**SHAFT REPAIR TOOL**



**REPAIR KIT**

# PORTABLE PNEUMATIC TUBE CLEANERS

1/4" & UP  
I.D.

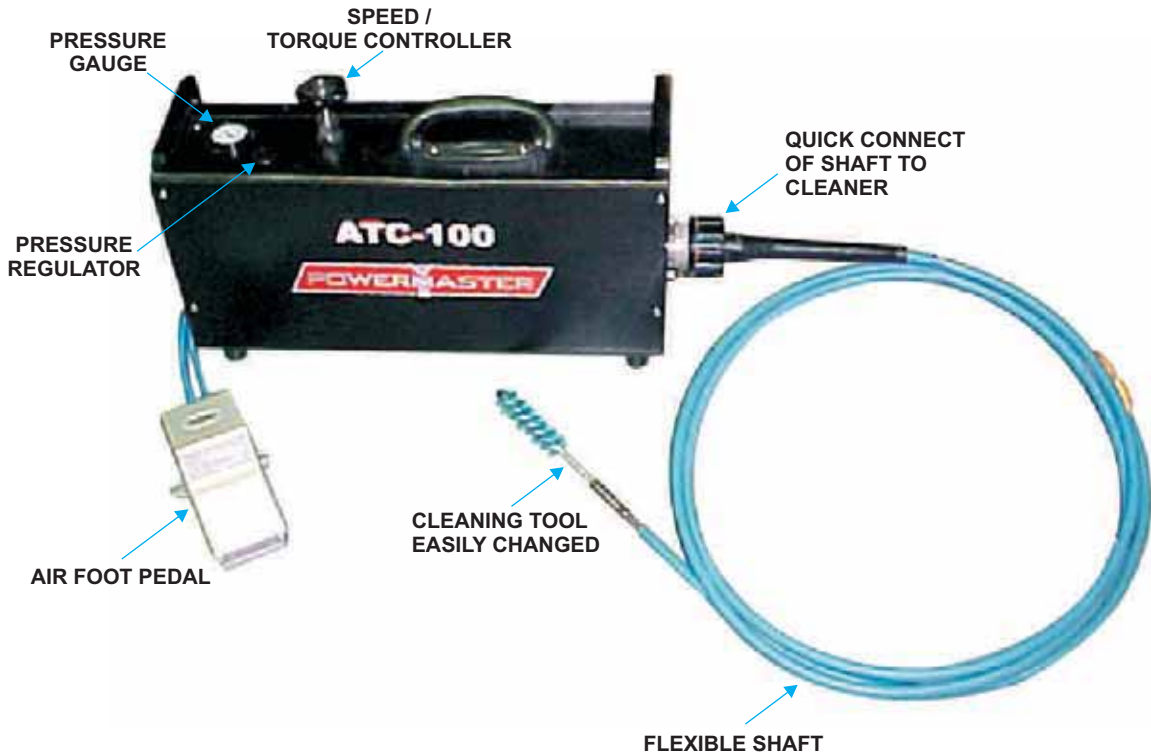

## Features :

- Shock Resistant - Excellent for applications where use of electric equipment is hazardous.
- Versatile - Interchangeability of different size flexible shafts and cleaning tools.
- Speed/Torque control - Shaft rotation speed can be set at optimum for each application.
- No Tooling - Quick disconnection of flexible shaft.
- Time Saving - Simultaneous water flush to remove deposits from tubes.
- Cleanliness - Foot switch for operator's convenience to activate both shaft rotation and water flow to reduce water consumption and making working area clean.
- Compact - Light weight easy to operate inside drum.

Model-ATC-100 Portable Pneumatic Tube Cleaning Machine includes FRL unit, adjustable speed/torque control, and air foot pedal. The ATC-100 uses a cleaning tool mounted on the tip of a flexible shaft, which is available in different lengths and diameters to fit the size of the tube to be cleaned. For wet applications, as the shaft rotates inside its watertight nylon casing, the unit feeds water through the casing to the cleaning tool.

A foot switch controls shaft rotation and water flow. While the operator feeds the rotating shaft assembly through the tube, the waterflow softens the deposits before cleaning and flushes them out during cleaning.

Tube I.D. mm	Tube I.D. inch	Tube Cleaner Model No.	Motor Power		Motor Speed RPM	Air Supply		Weight		Dimension		
			HP	KW		Min	Max	lbs.	Kg.	High	Wide	Deep
6.4 & UP	1/4 & UP	ATC-100	1.7	1.1	300-3000	60psi @ 15cfm	100psi @ 70cfm	26	12	10.3/8"(655mm)	6"(152mm)	19"(483mm)



## 'PORTO' PORTABLE ELECTRIC TUBE CLEANERS



### Features :

- Compact and portable for use in multiple locations.
- Easy connect and disconnect of various shafts and cleaning tools.
- Foot Switch enables operator to concentrate on cleaning operation.
- Water moving through shaft flushes out deposits already dislodged by cleaning tools.

The 'PORTO' is built for users to whom a small size and easy transportation means they can clean more tubes faster. Used to clean 1/4" - 1" I.D. tubes in chillers, condensers, evaporators and heat exchangers. The flexible shaft rotates at 1760 rpm as water feeds through the nylon casing to the cleaning tool. As the tool removes the deposits, the water flow flushes them out. A solenoid valve ensures that water flows only when the machine is running. Water consumption can be regulated as needed.

Tube I.D.		Tube Cleaner Model No.	Motor Power		Motor Speed RPM	Weight		High	Dimension	
mm	inch		HP	KW		lbs.	Kg.		Wide	Deep
6.4-25.4	1/4-1	PORTO	1/2	0.40	1760	36	16	10"(254mm)	11"(279mm)	18"(457mm)

All units available in your choice of :  
 110v 60Hz, 110v 50Hz - 9 Amps. 220v 60Hz, 220v 50Hz - 4.5 Amps.  
 Please Specify when ordering.

## 'TCS-PORTO' PORTABLE ELECTRIC TUBE CLEANINGS SYSTEM

### MODEL TCS-PORTO CHILLER TUBE CLEANING SYSTEM

**Model TCS-PORTO** Chiller tube cleaning system is the most common system for cleaning chillers by users to whom size and portability is paramount.

- CONTENTS**
- 'PORTO' Portable Tube Cleaner - 1 no.
  - PFS - 500 - 140 Flexible Shafts - 2 nos.
  - Nylon Brush (specify size) - 25 nos.
  - Repair kit for flexible shaft PFS-500 consisting of 4 drive end couplings, 4 tool end couplings, 1 shaft repair tool with hammer, 1 flexible shaft lubricator and 2 bottles of lubricant.



# FLEXIBLE SHAFTS

1/4" - 1"  
I.D.

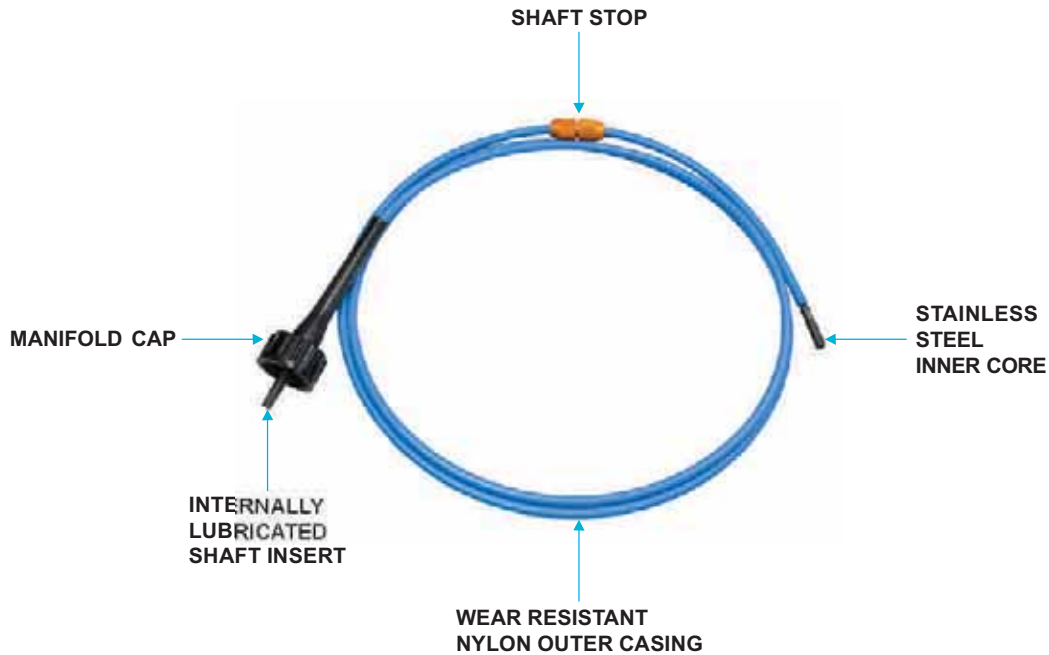

## For PTC-40, PTC-60 FLEXIBLE SHAFTS WITH STAINLESS STEEL INNER CORE

When ordering flexible shafts and accessories, each item should be ordered for specific tube/pipe size or size range. Shafts have color coded shaft stops for easy identification. Stainless Steel inner cores ensure our shafts have longest life, flexibility and resistance to corrosion. Since the inner core of the shafts are the heart of the system and take most of the strain, stainless steel inner cores cause our shafts to last longer than the competition.

To order Flexible Shaft(s), determine tube I.D.(s) and length of the longest tube(s). Order Flexible Shaft(s) to correspond with tube I.D.(s) and lengths. Please ask us for special or longer lengths.

Tube I.D. Range mm	Tube I.D. Range inch	Flexible Shaft Model No.	Flexible Shaft Length		Shaft Core O.D.		Shaft Casing O.D.		Tool End Thread
			feet	mtrs	mm	inch	mm	inch	
6.4-9.5	1/4-3/8	PFS-250-40	13	4.0	3.2	1/8	6.4	1/4	8 - 32 F
		PFS-250-79	26	7.9					
11.1-12.7	7/16-1/2	PFS-375-40	13	4.0	6.4	1/4	9.5	3/8	1/4 -28 F
		PFS-375-55	18	5.5					
		PFS-375-79	26	7.9					
		PFS-375-110	36	11.0					
		PFS-375-140	46	14.0					
14.3-25.4	9/16-1	PFS-500-40	13	4.0	7.9	5/16	12.7	1/2	1/4 -28 F
		PFS-500-55	18	5.5					
		PFS-500-79	26	7.9					
		PFS-500-110	36	11.0					
		PFS-500-140	46	14.0					
		PFS-500-184	61	18.4					
		PFS-500-232	76	23.2					

## FLEXIBLE SHAFTS FOR INTERNALLY GROOVED TUBES

Tube I.D. Range mm	Tube I.D. Range inch	Flexible Shaft Model No.	Flexible Shaft Length		Shaft Core O.D.		Shaft Casing O.D.		Tool End Thread
			feet	mtrs	mm	inch	mm	inch	
17.5-25.4	11/16-1	PFS-560-40	13	4.0	9.5	3/8	14.3	9/16	1/4 - 28
		PFS-560-55	18	5.5					
		PFS-560-79	26	7.9					
		PFS-560-110	36	11.0					
		PFS-560-140	46	14.0					
		PFS-560-186	61	18.6					
		PFS-560-232	75	23.2					

**Note :** PFS - 560 shafts can be supplied with Teflon<sup>®</sup> casing for when using dry. To order add suffix "T" to shaft number. Teflon is a trademark of Du Pont Company.

**Note:** See page 102 for shaft repair equipment.



## BRUSHES

**NYLON BRUSHES** Used for removing soft scales in ferrous (carbon steel, stainless steel) and non-ferrous tubes (copper, brass, plastic, etc.) and for final 'finishing' of tubes.



NYLON BRUSH

**STAINLESS STEEL BRUSHES** Used for removing soft and light scale deposits in ferrous tubes (carbon steel, stainless steel, etc.).



STAINLESS STEEL BRUSH

**BRASS BRUSHES** Used for removing soft and light scale deposits in straight, non-ferrous tubes. (Copper, brass, nickel and their alloyed tubes).



BRASS BRUSH

Brush O.D.		Nylon Brush	Stainless Steel	Brass Brush	Threading	Coupling
mm	inch					
6.4	1/4	N - 250	SS - 250	B - 250	8 - 32F	P-1 (8 - 32M x 8 - 32M)
7.9	5/16	N - 312	SS - 312	B - 312	8 - 32F	P-1 (8 - 32M x 8 - 32M)
9.5	3/8	N - 375	SS - 375	B - 375	12 - 24F	P-2 (8 - 32M x 12 - 24M)
11.1	7/16	N - 437	SS - 437	B - 437	1/4 - 28M	-
12.7	1/2	N - 500	SS - 500	B - 500	1/4 - 28M	-
14.3	9/16	N - 562	SS - 562	B - 562	1/4 - 28M	-
15.9	5/8	N - 625	SS - 625	B - 625	1/4 - 28M	-
17.5	11/16	N - 687	SS - 687	B - 687	1/4 - 28M	-
19.1	3/4	N - 750	SS - 750	B - 750	1/4 - 28M	-
20.6	13/16	N - 812	SS - 812	B - 812	1/4 - 28M	-
22.2	7/8	N - 875	SS - 875	B - 875	1/4 - 28M	-
23.8	15/16	N - 937	SS - 937	B - 937	1/4 - 28M	-
25.4	1	N - 1000	SS - 1000	B - 1000	1/4 - 28M	-

- Brushes should be ordered so that brush O.D. is marginally less than tube I.D., for it to easily enter tube with deposit.

### DRILL TIP DOUBLE DIAMETER BRUSHES



DRILL TIP DOUBLE DIAMETER NYLON BRUSH



DRILL TIP DOUBLE DIAMETER BRASS BRUSH

Tube I.D.		Drill Tip Nylon Brush	Drill Tip Brass Brush
mm	inch		
15.9	5/8	DTBN-625	DTBB-625

### DRILL TIP DOUBLE DIAMETER BRUSHES

These brushes are used to clean internally grooved tubes. The drill tip of brushes cleans through hard scale before the brush cleaning action takes over. The large diameter of this brush cleans into the grooves of the tubes and the small diameter into the lands of the tube's rifling.

## COLOR CODED SHOOT THRU SCRUBBERS

Tube I.D.		Scrubber O.D. (inch)	Model	Color	Type
mm	inch				
12.57-13.74	0.495-0.541	0.560	SC-560-S	Gold	Soft
13.39-14.10	0.527-0.555	0.560	SC-560	Gold	Hard
14.50-15.75	0.570-0.620	0.630	SC-630-S	Brown	Soft
15.00-16.00	0.590-0.630	0.630	SC-630	Brown	Hard
15.75-17.15	0.620-0.675	0.695	SC-695-S	Orange	Soft
16.56-17.63	0.652-0.694	0.695	SC-695	Orange	Hard
16.76-18.54	0.660-0.730	0.750	SC-750-S	Violet	Soft
18.03-19.05	0.710-0.750	0.750	SC-750	Violet	Hard
18.54-20.32	0.730-0.800	0.825	SC-825-S	White	Soft
19.74-20.80	0.777-0.819	0.825	SC-825	White	Hard
19.81-21.60	0.780-0.850	0.870	SC-870-S	Lime	Soft
20.96-22.10	0.825-0.870	0.870	SC-870	Lime	Hard
22.10-24.00	0.870-0.944	0.960	SC-960-S	Blue	Soft
22.50-24.13	0.886-0.950	0.960	SC-960-M	Blue	Medium
22.91-24.28	0.902-0.956	0.960	SC-960	Blue	Hard
25.40-27.56	1.000-1.085	1.100	SC-1100-S	Black	Soft
26.09-28.09	1.027-1.106	1.100	SC-1100	Black	Hard

In most cases hard tube scrubbers are recommended for removing light to medium deposits in condensers. They work by being 'Shot Thru' the tubes with a high pressure air gun. Order tube scrubbers by model and color.

**Features :**

- Scrubbers are shot thru tubes with a gun using compressed air and water.
- The scraping disks will not damage inside of tubes.
- Scrubbers float for easy retrieval.
- Reuseable.



## CLEANING ACCESSORIES



**BUFFING TOOL**



**REPLACEMENT BLADES**



**BUFFING TOOL WITH DRILL TIP**

**BUFFING TOOLS** are used for final polishing or removal of light and soft deposits from ferrous and non-ferrous tubes that have been previously cleaned. Used in straight or very large radius tubes in a clockwise direction only.

Tube I.D.		Buffing Tool	With Drill Tip	Replacement Blades	Adjusting Tool
mm	inch				
7.9-9.5	5/16-3/8	PBT-1	PBT-1-T	PBB-1	PBT-AT
9.5-12.7	3/8-1/2	PBT-2	PBT-2-T	PBB-1	PBT-AT
12.7-14.3	1/2-9/16	PBT-3	PBT-3-T	PBB-2	-
15.9-25.4	5/8-1	PBT-4	PBT-4-T	PBB-3	-

**CARBIDE DRILLS** for heavily choked tubes

Tube I.D.		Carbide Drill
mm	inch	
6.4	1/4	CB-250
9.5	3/8	CB-375
11.1	7/16	CB-430
12.7	1/2	CB-500
14.3	9/16	CB-560
15.9	5/8	CB-625
17.5	11/16	CB-680



**CARBIDE DRILL**

**CARBIDE DRILLS** are used for cleaning tubes choked solidly with hard deposits.



CLEANING ACCESSORIES

**U-TUBE TOOLS** These tools are used to clean tubes that have sharp bends in them. They consist of a brush or cobalt tip mounted on a piece of flexible shaft so the tool can negotiate the bend.

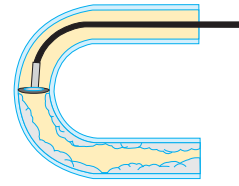

**CUP BRUSH TOOLS - Brass or Stainless Steel**

Tube I.D.		Cup Brush Tools
mm	inch	
12.7-19.1	1/2-3/4	CBT-500B
12.7-19.1	1/2-3/4	CBT-500SS



CUP BRUSH TOOL

**WHEEL BRUSH TOOLS - Brass or Stainless Steel**

Tube I.D.		Wheel Brush Tools
mm	inch	
20.6-25.4	13/16-1	WBT-813B
20.6-25.4	13/16-1	WBT-813SS



WHEEL BRUSH TOOL

**COBALT TIP TOOLS**

Tube I.D.		Cobalt Tip Tools
mm	inch	
12.7	1/2	CTT-500
15.9	5/8	CTT-625



COBALT TIP TOOL

For sizes not listed above please contact us.

**SHAFT REPLACEMENT COUPLINGS**

Flexible Shaft Model	PFS-250	PFS-375	PFS-500	PFS-560	PFS-750
Tool Coupling	TC-250	TC-375	TC-500	TC-560	TC-750
Case Coupling	CC-250	CC-375	CC-500	CC-560	CC-750
Manifold Cap	MC-1	MC-1	MC-1	MC-1	MC-1
Shaft Washer	3/16x3/4	5/16x3/4	7/16x3/4	9/16x7/8	11/16x1
Drive Coupling	DC-250	DC-375	DC-500	DC-560	DC-750
Nylon Guard	NG-250	NG-250	NG-500	NG-500	NG-750

**FLEXIBLE SHAFT REPAIR AND MAINTENANCE**  
For PFS-250, PFS-375, PFS-500, PFS-560 and PFS-750 Flexible Shaft

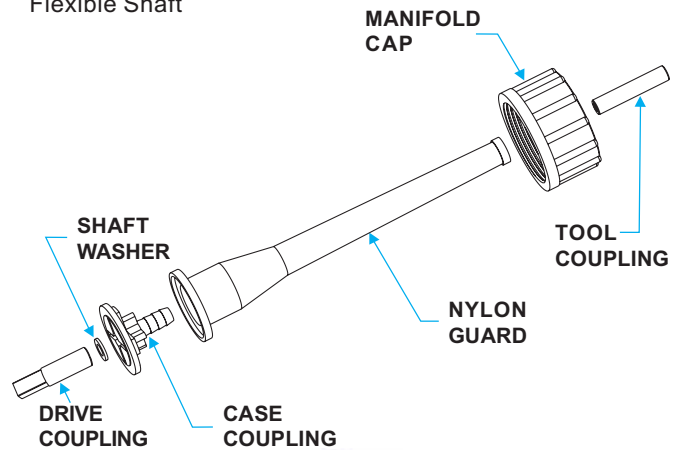

**SHAFT REPAIR TOOL** allows users to quickly and safely attach couplings onto the shaft ensuring maximum useful life for the shaft.

SHT-1 Shaft Repair Tool with Hammer.  
SHP-1 Replacement Hammer.



SHAFT REPAIR TOOL

**FLEXIBLE SHAFT LUBRICATOR** is used to lubricate flexible shafts for maximum useful life. They are also used to lubricate shafts prior to storage. The lubricator is filled with a water soluble lubricant that enters and lubricates the shaft when air supply is provided to the lubricator. The residue lubricant washes out with water when the shaft is used again.

PFSL-1 Flexible Shaft Lubricator.  
PLUBE Lubricant for flexible shaft lubricator, 8 ounces (0.25 litres).



LUBRICANT



FLEXIBLE SHAFT LUBRICATOR





FLEXIBLE SHAFT

## For PTC-75, PTC-150

To order flexible shaft(s), determine tube I.D.(s) and length of longest tubes. Order flexible shaft(s) to correspond with tube I.D.(s) and lengths. (Consult factory for longer shafts if required.)

### FLEXIBLE SHAFTS (Wet application - Nylon casing) for tubes 1" (25.4mm) I.D. and UP

Tube I.D. Range		Flexible Shaft Model No.	Flexible Shaft Length		Shaft Core O.D.		Shaft Casing O.D.		Tool End Thread
mm	inch		feet	mtrs	mm	inch	mm	inch	
25.4	1	PFS-750-49	16	4.9	12.7	1/2	19.1	3/4	1/2 - 12F
		PFS-750-79	26	7.9					
		PFS-750-110	36	11.0					
		PFS-750-155	51	15.5					



FLEXIBLE SHAFT

### FLEXIBLE SHAFTS (Dry application - Steel casing) for tubes 1" (25.4mm) I.D. and UP

Tube I.D. Range		Flexible Shaft Model No.	Flexible Shaft Length		Shaft Core O.D.		Shaft Casing O.D.		Tool End Thread
mm	inch		feet	mtrs	mm	inch	mm	inch	
25.4	1	PFS-875-49	16	4.9	12.7	1/2	22.2	7/8	1/2 - 12F
		PFS-875-79	26	7.9					
		PFS-875-110	36	11.0					
		PFS-875-155	51	15.5					

### FLEXIBLE SHAFTS (Dry application - Stainless steel casing) for tubes 1" (25.4mm) I.D. and UP

Tube I.D. Range		Flexible Shaft Model No.	Flexible Shaft Length		Shaft Core O.D.		Shaft Casing O.D.		Tool End Thread
mm	inch		feet	mtrs	mm	inch	mm	inch	
25.4	1	PFS-875-49-SS	16	4.9	12.7	1/2	22.2	7/8	1/2 - 12F
		PFS-875-79-SS	26	7.9					
		PFS-875-110-SS	36	11.0					
		PFS-875-155-SS	51	15.5					

## BRUSHES

**NYLON BRUSHES** Recommended for removing soft scales in straight, non-ferrous tubes. (copper, brass, plastic, etc.) and ferrous (stainless steel, carbon steel) and for final 'finishing' of tubes. Order brush so that brush O.D. is marginally smaller than tube I.D.

**BRASS BRUSHES** Recommended for removing soft and light scale deposits in straight, non-ferrous tubes. Order brush so that brush O.D. is marginally smaller than tube I.D.

**STAINLESS STEEL BRUSHES** Recommended for removing soft and light scale deposits in straight, ferrous tubes. (carbon steel, stainless steel, etc.). Order brush so that brush O.D. is marginally smaller than tube I.D.

Brush O.D.		Nylon Brush	Brass Brush	Stainless Steel
mm	inch			
31.7	1.1/4	N - 1250	B - 1250	SS - 1250
38.1	1.1/2	N - 1500	B - 1500	SS - 1500
44.5	1.3/4	N - 1750	B - 1750	SS - 1750
51.0	2	N - 2000	B - 2000	SS - 2000
57.1	2.1/4	N - 2250	B - 2250	SS - 2250
63.5	2.1/2	N - 2500	B - 2500	SS - 2500
70.0	2.3/4	N - 2750	B - 2750	SS - 2750
76.2	3	N - 3000	B - 3000	SS - 3000
82.6	3.1/4	N - 3250	B - 3250	SS - 3250
89.0	3.1/2	N - 3500	B - 3500	SS - 3500
95.2	3.3/4	N - 3750	B - 3750	SS - 3750
101.6	4	N - 4000	B - 4000	SS - 4000



NYLON BRUSH



BRASS BRUSH



STAINLESS STEEL BRUSH

1" & UP  
I.D.

**BRUSHES & ACCESSORIES**

**CARBON STEEL BRUSHES** Recommended for removing soft and light scale deposits in straight, ferrous tubes. Order brush so that brush O.D. is marginally smaller than tube I.D.

**PLASTIC BRUSHES** Recommended for removing soft deposits in straight, ferrous and non-ferrous tubes and for final 'finishing' up of cleaning in hoses, tubes and pipes. Order brush so that brush O.D. is marginally smaller than tube I.D.

Brush O.D.		Carbon Steel	Plastic Brush
mm	inch		
127.0	5	CS - 5000	P - 5000
152.4	6	CS - 6000	P - 6000
178.0	7	CS - 7000	P - 7000
203.2	8	CS - 8000	P - 8000
228.6	9	CS - 9000	P - 9000
254.0	10	CS - 10000	P - 10000
279.4	11	CS - 11000	P - 11000
305.0	12	CS - 12000	P - 12000
330.2	13	CS - 13000	P - 13000
355.6	14	CS - 14000	P - 14000

**Note :** Brushes over 1" O.D. require # TCB-C coupling to connect to PFS-750, PFS-875 and PFS-875-SS



**CARBON STEEL BRUSH**



**PLASTIC BRUSH**

**DRILL TIP DOUBLE DIAMETER BRUSHES**

These brushes are used to clean internally grooved tubes. The drill tip of brushes cleans through hard scale before the brush cleaning action takes over. The large diameter of this brush, cleans into the grooves of the tubes and the small diameter into the lands of the tube's rifling.

Tube I.D.		Drill Tip Nylon Brush	Drill Tip Brass Brush
mm	inch		
25.4	1	DTBN-1000	DTBB-1000
31.7	1.1/4	DTBN-1250	DTBB-1250



**DRILL TIP NYLON BRUSH**



**DRILL TIP BRASS BRUSH**

**CIRCULAR BRUSH TOOLS FOR STRAIGHT TUBES**

These tools consist of 4 stainless steel circular brushes that are mounted on a shaft and connected to a Universal Joint. These tools are used to clean soft to medium scales. Replacement circular brushes can be ordered when wear starts.



**CIRCULAR BRUSH  
(FOR STRAIGHT TUBES)**

Straight Tube I.D.		Circular Brush Tool Model	Brush O.D.		Spare Brush Model (4 needed)	Spare Universal Joint Model
mm	inch		mm	inch		
28.6-33.3	1.1/8-1.5/16	CBTS-1125	25.4	1	CBSB-1125	UCT-1063
35.0-39.7	1.3/8-1.9/16	CBTS-1375	31.7	1.1/4	CBSB-1375	UCT-1063
41.3-47.1	1.5/8-1.13/16	CBTS-1625	38.1	1.1/2	CBSB-1625	UCT-1063
47.6-52.6	1.7/8-2.1/16	CBTS-1875	44.5	1.3/4	CBSB-1875	UCT-1250
54.0-58.7	2.1/8-2.5/16	CBTS-2125	51.0	2	CBSB-2125	UCT-1250
60.3-65.1	2.3/8-2.9/16	CBTS-2375	57.1	2.1/4	CBSB-2375	UCT-1250
66.7-71.6	2.5/8-2.13/16	CBTS-2625	63.5	2.1/2	CBSB-2625	UCT-1250
73.0-77.8	2.7/8-3.1/16	CBTS-2875	70.0	2.3/4	CBSB-2875	UCT-1250
79.4-84.2	3.1/8-3.5/16	CBTS-3125	76.2	3	CBSB-3125	UCT-1250

**Note :** For larger sizes, please enquire.

## CIRCULAR BRUSH TOOLS FOR CURVED TUBES

These tools consist of 2 stainless steel circular brushes that are mounted onto a Double Universal Joint for maximum flexibility. These tools are used to clean soft to medium scales. Replacement circular brushes can be ordered when wear starts.



CIRCULAR BRUSH (FOR CURVED TUBES)

Curved Tube I.D.		Circular Brush Tool Model	Brush O.D.		Spare Brush Model (2 needed)	Spare Universal Joint Model
mm	inch		mm	inch		
31.7-35.6	1.1/4-1.7/16	CBTC-1125	25.4	1	CBSB-1125	UCT-1500
38.1-42.9	1.1/2-1.11/16	CBTC-1500	31.7	1.1/4	CBSB-1375	UCT-1500
44.5-49.2	1.3/4-1.15/16	CBTC-1750	38.1	1.1/2	CBSB-1625	UCT-1500
51.0-55.6	2-2.3/16	CBTC-2000	44.5	1.3/4	CBSB-1875	UCT-1250
57.1-61.9	2.1/4-2.7/16	CBTC-2250	51.0	2	CBSB-2125	UCT-1250
63.5-68.3	2.1/2-2.11/16	CBTC-2500	57.1	2.1/4	CBSB-2375	UCT-1250
70.0-74.6	2.3/4-2.15/16	CBTC-2750	63.5	2.1/2	CBSB-2625	UCT-1250
76.2-81.0	3-3.3/16	CBTC-3000	70.0	2.3/4	CBSB-2875	UCT-1250
82.6-90.6	3.1/4-3.9/16	CBTC-3250	76.2	3	CBSB-3125	UCT-1250

**Note :** For larger sizes, please enquire.



BUFFING TOOL



BUFFING TOOL WITH DRILL TIP



REPLACEMENT BLADES

## BUFFING TOOLS for Tubes/Pipes 1"-3" (25.4-76.2mm) I.D.

Buffing tool are used for final polishing or removal of light and soft deposits from ferrous and non-ferrous tubes that have been previously cleaned.

Used in straight or very large radius tubes in a clockwise direction only.

**PBT-7** Buffing Tools for tubes 1"-3" (25.4-76.2mm) I.D.

**PBT-7-T** Buffing Tools for tubes 1"-3" (25.4-76.2mm) with drill tip.

**PBB-5** Replacement Blades for PBT-7.

## CARBIDE DRILLS for Heavily choked tubes.

Carbide Drills are used for cleaning tubes choked solidly with hard deposits.

Tube I.D.		Carbide Drill
mm	inch	
19.1	3/4	CB-750
22.2	7/8	CB-875
25.4	1	CB-1000



CARBIDE DRILL



CLEANING ACCESSORIES

**CONE CUTTER TOOLS** These tools use patented ergocentric cutters to clean hard scale from typically larger tubes that are found in boilers. The ergocentric cutters ensure that the same tooth does not touch the same spot when cleaning and prevents grooves being formed in the tube scale. All cone cutter tools are fitted with universal joints to negotiate bends in curved tubes.

**ONE CONE TOOL** These consist of 1 Cone fitted onto a Universal Joint and are used when scale build up is not severe.

**TWO CONE TOOL** These consist of 2 Cones fitted onto a Universal Joint and are used when scale build up is severe.



SPARE CONE

Straight Tube I.D.		Curved Tube I.D.		One Cone Tool Model	Two Cone Tool Model	Cone Diameter		Spare Cone Model	Spare Universal Joint Model
m m	inch	m m	inch			m m	inch		
27.0-33.3	1.1/16-1.5/16	30.2-36.5	1.3/16-1.7/16	OCT-1063	TCT-1063	23.8	15/16	SCT-937	UCT-1063
31.7-36.5	1.1/4-1.7/16	36.5-42.9	1.7/16-1.11/16	OCT-1250	TCT-1250	27.0	1.1/16	SCT-1062	UCT-1250
35.0-39.7	1.3/8-1.9/16	42.9-49.2	1.11/16-1.15/16	OCT-1375	TCT-1375	30.2	1.3/16	SCT-1187	UCT-1250
38.1-46.0	1.1/2-1.13/16	49.2-55.5	1.15/16-2.3/16	OCT-1500	TCT-1500	36.5	1.7/16	SCT-1437	UCT-1250
44.5-58.7	1.3/4-2.1/16	55.5-61.9	2.3/16-2.7/16	OCT-1750	TCT-1750	42.9	1.11/16	SCT-1687	UCT-1250
50.8-60.3	2-2.3/8			OCT-2000	TCT-2000	49.2	1.15/16	SCT-1937	UCT-1250



ONE CONE TOOL



TWO CONE TOOL



THREE CONE TOOL

**THREE CONE TOOL**

These consist of 3 Cones fitted onto a base which is fitted with a Universal Joint and are used for cleaning larger (2.5/16" I.D. and up) tubes where scale build up is severe.

Straight Tube I.D.		Curved Tube I.D.		Three Cone Tool Model	Spare Cone Model	Spare Base Model	Spare Universal Joint Model
m m	inch	m m	inch				
58.7-73.0	2.5/16-2.7/8	61.9-79.4	2.7/16-3.1/8	PCT-2313	SCT-937	CTB-2313	UCT-1250
71.4-85.7	2.13/16-3.3/8	77.8-93.7	3.1/16-3.11/16	PCT-2813	SCT-937	CTB-2813	UCT-1250
84.1-96.8	3.5/16-3.13/16	92.1-103.2	3.5/8-4.1/16	PCT-3313	SCT-1062	CTB-2813	UCT-1250

**SCRAPER TOOLS**

Scraper Tools use scrapper blades that 'fly out' when the tool is rotated, coming into contact with scale and scraping it out. These tools can be coupled with brushes for simultaneous 'finishing' of the cleaning operation as with carbide drills to initially drill through tubes that have very hard deposits.

Straight Tube I.D.		Curved Tube I.D.		Scraper Tool Model
m m	inch	m m	inch	
20.6-39.7	13/16-1.9/16	23.8-46.0	15/16-1.13/16	SCR-813
36.5-58.7	1.7/16-2.1/16	42.9-65.1	1.11/16-2.9/16	SCR-1438
42.9-77.8	1.11/16-3.1/16	61.9-77.8	2.7/16-3.1/16	SCR-1687



FLEX HUB ASSEMBLY



REPLACEMENT BLADES



CARBIDE DRILL



UNIVERSAL JOINT

**SPARES FOR SCRAPER TOOLS**

- Model **SCR-813-SB** Spare Set of 3 Scraping Blades for SCR-813.
- Model **SCR-1438-SB** Spare Set of 3 Scraping Blades for SCR-1438.
- Model **SCR-1687-SB** Spare Set of 3 Scraping Blades for SCR-1687.
- Model **CB-750** Carbide Drill for use with SCR-1438 Scraper tool to drill through tubes with very hard deposits.
- Model **CB-875** Carbide Drill for use with SCR-1687 Scraper tool to drill through tubes with very hard deposits.
- Model **UCT-1250** Universal Joint for use with scraper tool for use with curved tubes.

## COMBINATION CONE-CARBIDE DRILL TOOL

These combination tools use the extreme hardness of a carbide drill coupled with the ergocentric cleaning properties of cone cleaning cutters to drill through and simultaneously clean tubes that are choked with very hard deposits.

Tube I.D.		Combination Cone-Carbide Drill Tool Model
mm	inch	
23.8-27.0	15/16-1.1/16	CCD-938
27.0-30.2	1.1/16-1.3/16	CCD-1063
30.2-36.5	1.3/16-1.7/16	CCD-1188
36.5-42.9	1.7/16-1.11/16	CCD-1438
42.9-49.2	1.11/16-1.15/16	CCD-1687



COMBINATION CONE-CARBIDE DRILL TOOL

## CYLINDER CUTTER TOOL

These tools are used typically in boilers and other larger tubes that have a light to medium deposit. These tools use patented ergonomic cutting wheels that ensure the same tooth of the cutter wheel does not touch the same spot when cleaning. This prevents grooves being formed in the tube scale. The cutters 'fly out' when the tool is rotated and perform cleaning action.

Tube I.D.		Cylinder Cutter Tool Model	Spare Cylinder Cutter Model
mm	inch		
36.5-47.6	1.7/16-1.7/8	CCT-1438	CYC-1438
46.0-73.0	1.13/16-2.7/8	CCT-1813	CYC-1438
55.5-81.0	2.3/16-3.3/16	CCT-2188	CYC-2188
79.4-98.4	3.1/8-3.7/8	CCT-3125	CYC-2188



CYLINDER CUTTER TOOL

## WING TOOLS-STIFF ARM CUTTER

These tools use long stiff arms with patented cone cutters on their ends, that spread out when rotated. These tools are used to clean light to medium deposits in large diameter tubes and pipes.

Tube I.D.		Wing Tool-Stiff Arm Cutter Model	Spare Cone Cutter Model
mm	inch		
42.9-101.6	1.11/16-4	WTS-1688	SCT-937
100.0-165.1	3.15/16-6.1/2	WTS-3938	SCT-937



WING TOOLS-STIFF ARM CUTTER

## WING TOOLS-FLEXIBLE ARM CUTTER

These tools are similar in operation to the Stiff Arm Winged Tools, but patented Cone Cutters are attached onto flexible arms. These tools are used in typically very large vertical pipes and are used in cleaning pipes from top to bottom.

Tube I.D.		Wing Tool - Flexible Arm Cutter Model	Spare Cone Cutter Model
mm	inch		
100.0-309.0	3.15/16-12	WTF-3938	SCT-937



WING TOOLS-FLEXIBLE ARM CUTTER

## WING TOOLS-FLEXIBLE ARM-CARBIDE BALL TIP

These tools are similar in operation to the Flexible Arm Cutter Wing Tools except these use carbide balls for removing light scale in large diameter tubes and pipes.

Tube I.D.		Wing Tool - Flexible Arm Carbide Ball Tip Model	Number of Balls Used
mm	inch		
23.8-52.4	15/16-2.1/16	WTC-938	4
49.2-103.2	1.15/16-4.1/16	WTC-1938	6
100.0-204.8	3.15/16-8.1/16	WTC-3938	6



WING TOOLS-FLEXIBLE ARM-CARBIDE BALL TIP

## WING TOOLS-FLEXIBLE NYLON ROD

These tools are fitted with abrasive nylon rods that spread out when rotated. These tools are used to clean light deposits in thin tubes and pipes of exotic materials where damage to tubes is to be avoided.

Tube I.D.		Wing Tool - Flexible Nylon Rod Model
mm	inch	
49.2-431.8	1.15/16-17	WTN-1938



WING TOOLS-FLEXIBLE NYLON ROD



# SHAFT REPAIR

## 1" & UP I.D.

### FLEXIBLE SHAFTS REPAIR / MAINTENANCE

For PFS-750, PFS-875 and PFS-875-SS Flexible Shafts

#### SHAFT REPAIR COUPLINGS

The life of flexible shafts can be extended by proper use and maintenance. If a flexible shaft should break at either end it can be easily repaired by cutting off the end portion and using a shaft repair tool to attach a coupling onto the cut shaft.

Flexible Shaft Model	PFS-875/ PFS-875-SS
Tool Coupling	TC-750
Case Coupling	CC-875
Manifold Cap	MC-2
Shaft Washer	9/16x7/8
Drive Coupling	DC-750
Brass Coupling	BC-875

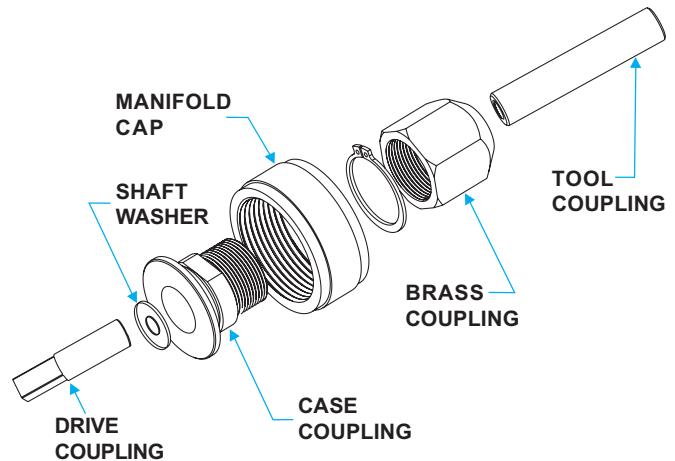

#### SHAFT REPAIR TOOL FOR FLEXIBLE SHAFT REPAIR

Allows users to quickly and safely attach couplings onto the shaft ensuring maximum useful life for the shaft.

- SHT-1** Shaft Repair Tool with Hammer.
- SHP-1** Replacement Hammer.



#### FLEXIBLE SHAFT LUBRICATOR

Is used to lubricate flexible shafts for maximum useful life. They are also used to lubricate shafts prior to storage. The lubricator is filled with a water soluble lubricant that enters and lubricates the shaft when air supply is provided to the lubricator. The residue lubricant washes out with water when the shaft is used again.

- PFSL-1** Flexible Shaft Lubricator.
- PLUBE** Lubricant for flexible shaft lubricator, 8 ounces (0.25 litres).



#### FLEXIBLE SHAFT REPAIR KITS

Flexible shaft repair kits include 4 drive end repair couplings, 4 tool end repair couplings, 1 shaft repair tool with punch, 1 flexible shaft lubricator, 2 bottles [8 ounce (0.25 liter) each] of lubricant for flexible shaft lubricator.

- REP-750-KIT** Repair kit for PFS-750, PFS-875 and PFS-875-SS Flexible shafts.



COMING SOON IN OUR TUBE CLEANER LINE

- 1) *Boiler Cleaning Systems (Twin Drive).*
- 2) *Shoot Thru Tube Cleaning Guns.*

And more.....

# PORTABLE PNEUMATIC TUBE CLEANERS

3/16"-2"  
I.D.

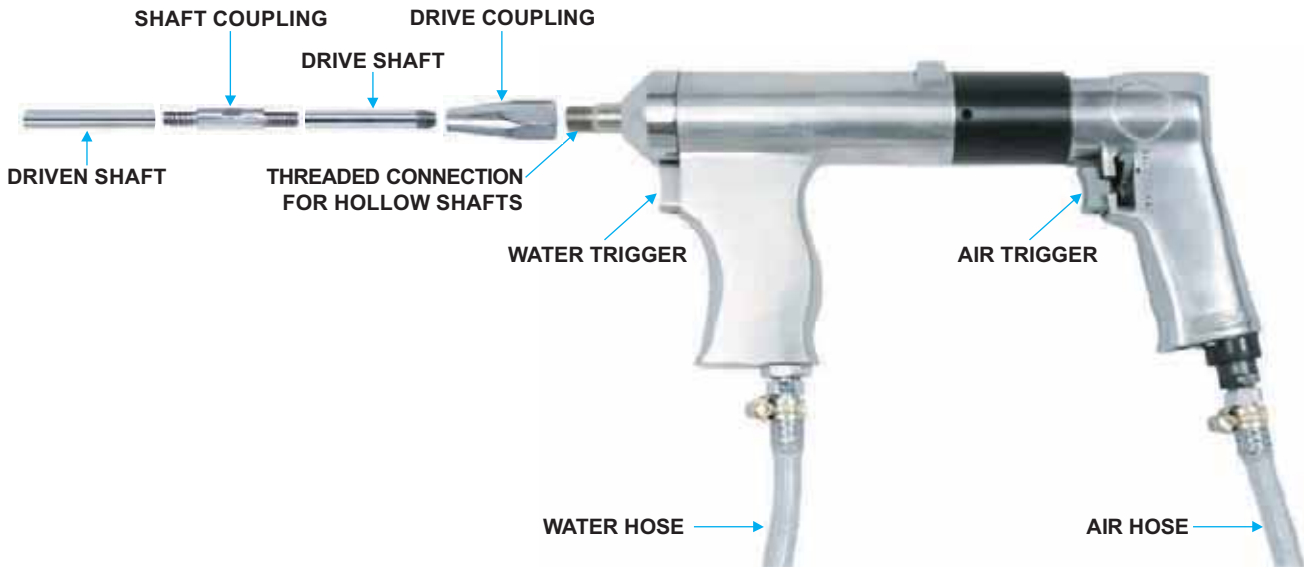

**Operation :** The portable pneumatic tube cleaners use hollow shafting of different diameters as per tube I.D. to be cleaned which can be coupled together to form lengths as per the length of the tube to be cleaned.

Water flows through the hollow tube and washes out deposits that are dislodged by the cleaning tools attached to the driven shafts. Typical cleaning tools used are carbide drills for severely clogged tubes, brushes for light deposits and buffing tools for final polishing of tubes. The water flow is independently controlled allowing the user to determine how much water is needed in the application.

Model **C-10** is typically used on oil coolers, small heat exchangers and condensers.

Model **CP-315** is typically used on larger diameter tubes of process vessels, heat exchangers and condensers.

Tube I.D.'s suited for		Model No.	Max Motor Power		Free Speed RPM	Air Supply		Water Supply		Weight	
mm	inch		HP	kW		Min	Max	Min	Max	lbs.	kg.
4.8-25.4	3/16-1	C-10	0.6	0.45	700	60psi@16cfm	90psi@16cfm	30psi	100psi	5.72	2.6
22.2-51.0	7/8-2	CP-315	1	0.746	1000	90psi@20cfm	90psi@40cfm	30psi	100psi	6.60	3.0

**Note :** The tube cleaners above are supplied with a heavy duty plastic carrying case with separate provision to house upto 8, 4ft. (1.2m) long hollow shafts, 15ft. (4.6m) air hose, 15ft. (4.6m) water hose.



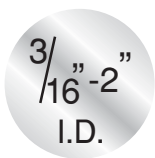

## PORTABLE PNEUMATIC TUBE CLEANER ACCESSORIES

• **Hollow Drive Shaft** - 4ft. (1.2m) long aircraft quality steel shafts to connect to drive.  
 Model **DS-300 to DS-500**  
 Model **DS-562 to DS-750**



• **Hollow Driven Shaft** - 4ft. (1.2m) long aircraft quality steel shafts to connect to driven shafts. Order quantities based on length of tube to be cleaned.  
 Model **DN-300 to DN-500**  
 Model **DN-562 to DN-750**



• **Drive Coupling** - To Couple hollow drive shaft to drive.  
 Model **DC-300 to DC-500**  
 Model **DC-562 to DC-750**



• **Shaft Coupling** - To Couple 2 hollow shafts together.  
 Model **SC-300 to SC-500**  
 Model **SC-562 to SC-750**



• **Starter Drill** - To make pilot holes in deposits of completely clogged tubes.  
 Model **SD-312 to SD-500**  
 Model **SD-562 to SD-750**



Tube I.D.'s suited for mm	Tube I.D.'s suited for inch	Drive Model No.	Hollow Drive Shaft Model No.	Hollow Driven Shaft Model No.	Drive Coupling Model No.	Shaft Coupling Model No.	Starter Drill Model No.
4.8-6.4	3/16-1/4	C-10	DS-300	DN-300	DC-300	SC-300	-
9.5	3/8		DS-312	DN-312	DC-312	SC-312	SD-312
11.1	7/16		DS-375	DN-375	DC-375	SC-375	SD-375
12.7-14.3	1/2-9/16		DS-437	DN-437	DC-437	SC-437	SD-437
15.9-17.5	5/8-11/16		DS-500	DN-500	DC-500	SC-500	SD-500
19.1-20.6	3/4-13/16		DS-562	DN-562	DC-562	SC-562	SD-562
22.2-25.4	7/8-1	CP-315	DS-625	DN-625	DC-625	SC-625	SD-625
27.0-51.0	1.1/16-2		DS-750	DN-750	DC-750	SC-750	SD-750

## CLEANING TOOLS FOR USE WITH PORTABLE PNEUMATIC TUBE CLEANERS

- **Nylon Brushes** - ..... Refer to pages 100, 103
- **Brass Brushes** - ..... Refer to pages 100, 103
- **Stainless Brushes** - ..... Refer to pages 100, 103
- **Buffing Tools** - ..... Refer to pages 101, 105
- **Carbide Drills** - ..... Refer to pages 101, 105



## PORTABLE PNEUMATIC TUBE CLEANING KITS



Build your own kit by adding price of Drive (C-10 or CP-315), Hollow Drive Shafts, Hollow Driven Shafts, Shaft Couplings, Drive Coupling based on length of tube to be cleaned and cleaning tools (Brushes, Carbide Drills, Buffing Tools).

We will supply all the above in a handy box at no extra charge ! The box will accomodate a maximum of 1 Drive + 4 Hollow Shafts + 5 Couplings + 18 Cleaning Tools (Brushes, Carbide Drills, Buffing Tools).



# SUGAR MILL TUBE CLEANERS

1" & UP  
I.D.

SUGAR MILL TUBE CLEANERS

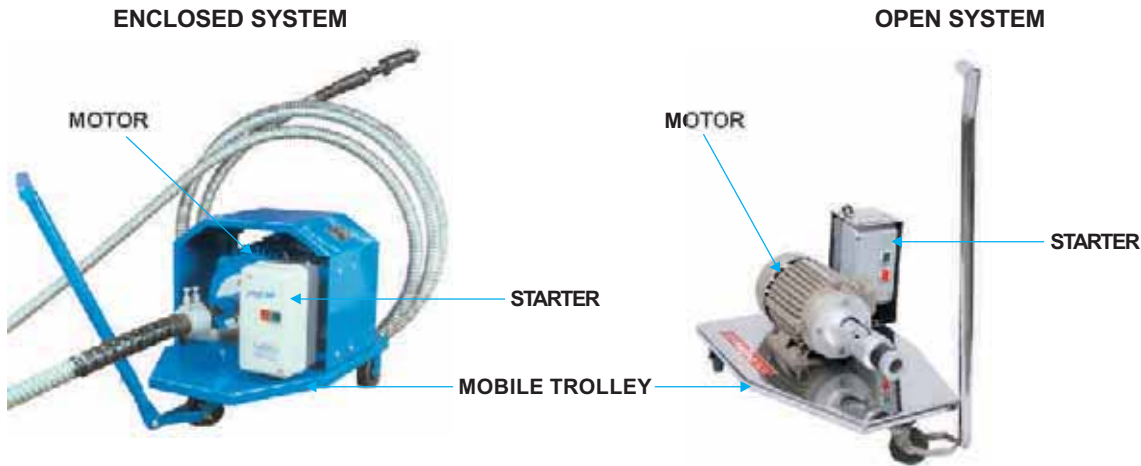

## FLEXIBLE SHAFT MACHINE (ELECTRICALLY DRIVEN)

**FLEXIBLE SHAFT MACHINE** is a self-contained portable unit, mounted on a 3-wheel trolley, fitted with a carrying handle. It incorporates a directly coupled, totally enclosed squirrel cage, 2800 rpm. continuously rated electric motor. Selecting the H.P. of the motor depends upon length and size of flexible shaft and nature of scaling. It is controlled by a push button starter which is provided with three thermal adjustable overload relays. Each machine is fully wired, carefully tested and is fitted with a 10-foot length of PVC Cable to main supply. Longer cable can be supplied upon request. Please consult us if your electric supply is different from listed below. Motors for alternate supplies are also available.

Model No.	Motor H.P.	Speed (RPM)	Electric Supply
TC-30	3.0	2800	440V 3 PHASE 50 Hz
TC-50	5.0		
TC-75	7.5		



## FLEXIBLE SHAFTS (DRIVES)

The Flexible Shaft transmits constant torque / power from the motor unit to the tool head or brush within the tube. **INNER CORE** - is double wound in opposing layers made out of high tensile-spring steel wires and passed through stress relieving process, made to absolute-vibration free performance and continuous duty.

**OUTER CASING** - is flexible, made out of galvanized steel strip and provided with special steel anti-friction lining for the entire length.

**CONNECTIONS** - Suitable motor connection at one end and detachable ball bearing hand piece (tool holder) with threaded spindle for tool head or brush at other end.

The size of the flexible shaft is based on internal diameter (I.D.) of the tube. The length of flexible shaft required is the addition of the length of the longest tube plus the distance between the mouth of the tube and the position of the power unit. The power unit should be located so that the flexible shaft be kept as straight as possible.

Inner Core mm (inch)		12 - 13 (1/2")	15 - 16 (5/8")	19 - 20 (3/4")
Outer Casing mm (inch)		25 - 26 (1")	31 - 32 (1.1/4")	34 - 35 (1.3/8")
<b>Length</b>				
<b>mtr.</b>	<b>feet</b>	<b>Model No.</b>	<b>Model No.</b>	<b>Model No.</b>
7.5	25.0	IFS-105-25	IFS-106-25	IFS-107-25
9.0	30.0	IFS-105-30	IFS-106-30	IFS-107-30
10.0	33.0	IFS-105-33	IFS-106-33	IFS-107-33
12.0	40.0	IFS-105-40	IFS-106-40	IFS-107-40
15.0	50.0	IFS-105-50	IFS-106-50	IFS-107-50
18.0	60.0	IFS-105-60	IFS-106-60	IFS-107-60
20.0	65.0	IFS-105-65	IFS-106-65	IFS-107-65
<b>Spare Inner Core Per mtr.</b>		IC-105	IC-106	IC-107
<b>Spare Outer Casing Per mtr.</b>		OC-105	OC-106	OC-107
<b>Spare Hand Piece</b>		HP-105	HP-106	HP-107

www.tubecleaners.com



1 1/4" - 4"  
I.D.

**SUGAR MILL WIRE BRUSHES  
FOR SUGAR MILL JUICE HEATERS, EVAPORATORS, BOILERS**



**"TH" FOR SOOT REMOVAL FROM SMOKE TUBES, GENERAL CLEANING.**



**"DS" FOR REMOVING LIGHT SCALE AND BURNISHING ALL TYPES OF TUBES.**



**"WBA" HEAVY DUTY BRUSHES.**



**"EXP" EXPANDING BRUSH FOR THIN SCALE, SOOT OR SOFT DEPOSITS.**



**"MB" FOR GENERAL PURPOSE POLISHING AND DEBURRING.**



**"CB" SPARE BRUSH WHEELS FOR "MB" BRUSHES.**



**"RS" HEAVY DUTY BRUSHES FOR HEAVY SCALE REMOVAL.**



**"EXS" EXPANDING SCRAPERS FOR THIN SCALE, SOOT OR SOFT DEPOSITS.**

Size		'TH' Turk Head Brush Model No.	'DS' Double Spiral Brush Model No.	'WBA' Brush Model No.	'EXP' Expanding Brush Model No.	'MB' Multi Purpose Brush Model No.	'CB' Circular Wheel Brush Model No.	'RS' Cup Shape Brush Model No.	'EXS' Expanding Scrapers Model No.
mm	inch								
31.7	1.1/4	TH-10	DS-10	WBA-10	EXP-10	MB-10	CB-10	-	EXS-10
35.0	1.3/8	TH-11	DS-11	WBA-11	EXP-11	MB-11	CB-11	-	EXS-11
38.1	1.1/2	TH-12	DS-12	WBA-12	EXP-12	MB-12	CB-12	-	EXS-12
41.3	1.5/8	TH-13	DS-13	WBA-13	EXP-13	MB-13	CB-13	-	EXS-13
44.5	1.3/4	TH-14	DS-14	WBA-14	EXP-14	MB-14	CB-14	-	EXS-14
47.6	1.7/8	TH-15	DS-15	WBA-15	EXP-15	MB-15	CB-15	-	EXS-15
50.8	2	TH-16	DS-16	WBA-16	EXP-16	MB-16	CB-16	RS-16	EXS-16
54.0	2.1/8	TH-17	DS-17	WBA-17	EXP-17	MB-17	CB-17	RS-17	EXS-17
57.1	2.1/4	TH-18	DS-18	WBA-18	EXP-18	MB-18	CB-18	RS-18	EXS-18
60.3	2.3/8	TH-19	DS-19	WBA-19	EXP-19	MB-19	CB-19	RS-19	EXS-19
63.5	2.1/2	TH-20	DS-20	WBA-20	EXP-20	MB-20	CB-20	RS-20	EXS-20
66.7	2.5/8	TH-21	DS-21	WBA-21	EXP-21	MB-21	CB-21	RS-21	EXS-21
70.0	2.3/4	TH-22	DS-22	WBA-22	EXP-22	MB-22	CB-22	RS-22	EXS-22
73.0	2.7/8	TH-23	DS-23	WBA-23	EXP-23	MB-23	CB-23	RS-23	EXS-23
76.2	3	TH-24	DS-24	WBA-24	EXP-24	MB-24	CB-24	RS-24	EXS-24
79.4	3.1/8	TH-25	DS-25	WBA-25	EXP-25	MB-25	CB-25	RS-25	EXS-25
82.5	3.1/4	TH-26	DS-26	WBA-26	EXP-26	MB-26	CB-26	RS-26	EXS-26
85.7	3.3/8	TH-27	DS-27	WBA-27	EXP-27	MB-27	CB-27	RS-27	EXS-27
88.9	3.1/2	TH-28	DS-28	WBA-28	EXP-28	MB-28	CB-28	RS-28	EXS-28
92.1	3.5/8	TH-29	DS-29	WBA-29	EXP-29	MB-29	CB-29	RS-29	EXS-29
95.2	3.3/4	TH-30	DS-30	WBA-30	EXP-30	MB-30	CB-30	RS-30	EXS-30
98.4	3.7/8	TH-31	DS-31	WBA-31	EXP-31	MB-31	CB-31	RS-31	EXS-31
101.6	4	TH-32	DS-32	WBA-32	EXP-32	MB-32	CB-32	RS-32	EXS-32

# SUGAR MILL CUTTER HEADS

1 1/4" - 4"  
I.D.



**SINGLE LAYER  
'H' TOOL**

**TWO LAYER  
'H' TOOL**

**THREE LAYER  
'H' TOOL**

**CLOSE 'HZ' TOOL  
(HZ-10 TO HZ-11)**

**OPEN 'HZ' TOOL  
(HZ-11A TO HZ-16)**

## 'H' TYPE CUTTER HEADS

for Tubes/Pipes 1.1/4"-4" (31.7mm-101.6mm) I.D.

These Cutter Heads are designed for cleaning straight and curved tubes as found in Boilers, Air Heaters, Economizers, etc. Cutter Heads are provided with 3 cutter wheels, one each of straight teeth, teeth cut right hand, teeth cut left hand, for quicker cleaning and prevention of scale grooving.

Model NO.	Tube I.D.		Cutter Wheels Set (3)	Spare Spindle
	mm	inch	Model No.	Model No.
H-10	31.7	1.1/4	HSRL-1	HA-1
H-11	35.0	1.3/8	HSRL-1	HA-1
H-12	38.1	1.1/2	HSRL-1	HA-1
H-13	41.3	1.5/8	HSRL-2	HA-2
H-14	44.5	1.3/4	HSRL-2	HA-2
H-15	47.6	1.7/8	HSRL-2	HA-2
H-16	51.0	2	HSRL-2	HA-2
H-17	54.0	2.1/8	HSRL-2	HA-2
H-18	57.1	2.1/4	HSRL-3	HA-3
H-20	63.5	2.1/2	HSRL-3	HA-3
H-22	70.0	2.3/4	HSRL-4	HA-3
H-24	76.2	3	HSRL-4	HA-3
H-26	82.5	3.1/4	HSRL-5	HA-3
H-28	88.9	3.1/2	HSRL-5	HA-3
H-30	95.2	3.3/4	HSRL-6	HA-4
H-32	101.6	4	HSRL-6	HA-4

## 'HZ' TYPE CUTTER HEADS

for Tubes/Pipes 1.1/4"-2" (31.7mm-51.0mm) I.D.

These spring loaded, self expanding Cutter Heads are designed for rapid removal of hard and obstinate scale formation in straight tubes as found in Evaporators, Juice Heaters, etc. It consists of 3 bevel, 4 straight cutter wheels, 4 left cutter wheels and 4 right cutter wheels, fitted on 3 bridge type arms.

Model NO.	Tube I.D.		Cutter Wheels Set (15)	Spare Arms
	mm	inch	Model No.	Model No.
HZ-10	31.7	1.1/4	HZSRL-1	HZA-1
HZ-10A	33.3	1.5/16	HZSRL-1	HZA-1
HZ-11	35.0	1.3/8	HZSRL-1	HZA-1
HZ-11A	36.5	1.7/16	HZSRL-1	HZA-2
HZ-12	38.1	1.1/2	HZSRL-1	HZA-2
HZ-12A	39.7	1.9/16	HZSRL-1	HZA-2
HZ-13	41.3	1.5/8	HZSRL-1	HZA-2
HZ-13A	42.9	1.11/16	HZSRL-1	HZA-2
HZ-14	44.5	1.3/4	HZSRL-2	HZA-3
HZ-14A	46.0	1.13/16	HZSRL-2	HZA-3
HZ-15	47.6	1.7/8	HZSRL-2	HZA-3
HZ-15A	49.2	1.15/16	HZSRL-2	HZA-3
HZ-16	51.0	2	HZSRL-2	HZA-3



## 'WA' TYPE CUTTER HEADS

for Tubes/Pipes 1.1/2"-4" (38.1mm-101.6mm) I.D.

These Cutter Heads produce excellent results in curved or straight tubes. Pivoted arms of Cutter Heads swing out by centrifugal force so that the cutters contact every part of the tube wall.

Model NO.	Tube I.D.		ConeCutter Set (3)	Spare Arms	Universal Joint
	mm	inch	Model No.	Model No.	Model No.
WA-12	38.1	1.1/2	WAL-1	WAA-1	WAUJ-1
WA-14	44.5	1.3/4	WAL-1	WAA-1	WAUJ-1
WA-16	51.0	2	WAL-1	WAA-1	WAUJ-1
WA-18	57.1	2.1/4	WAL-2	WAA-1	WAUJ-2
WA-20	63.5	2.1/2	WAL-2	WAA-1	WAUJ-2
WA-22	70.0	2.3/4	WAL-2	WAA-1	WAUJ-2
WA-24	76.2	3	WAL-3	WAA-2	WAUJ-2
WA-28	88.9	3.1/2	WAL-3	WAA-2	WAUJ-2
WA-32	101.6	4	WAL-4	WAA-2	WAUJ-2



## 'SA' TYPE CUTTER HEADS

for Tubes/Pipes 2"-4" (51.0mm-101.6mm) I.D.

These Cutter Heads have 3 to 5 freely pivoted arms, activated centrifugally, which swing out to give access to any part of tube wall.

Model NO.	Tube I.D.		Cone & Flat Cutter Set (9)	Arms	Universal Joint
	mm	inch	Model No.	Model No.	Model No.
SA-16	51.0	2	SAFC-1	SAA-1	SAUJ-1
SA-18	57.1	2.1/4	SAFC-2	SAA-2	SAUJ-2
SA-20	63.5	2.1/2	SAFC-2	SAA-2	SAUJ-2
SA-22	70.0	2.3/4	SAFC-3	SAA-2	SAUJ-2
SA-24	76.2	3	SAFC-3	SAA-2	SAUJ-2
SA-28	88.9	3.1/2	SAFC-4	SAA-2	SAUJ-2
SA-32	101.6	4	SAFC-5	SAA-3	SAUJ-2

1 1/2" - 7"  
I.D.

## CUTTER HEADS FOR STRAIGHT TUBES IN REFINERIES AND STILL TUBES



'P' & 'TC' TYPE

The model "P" & "TC" cutter head is used for cleaning straight tubes from 1-1/2" I.D. through 7" I.D. It is usually direct coupled to drive motor but flexible couplings, universal joints or flexible holders, are used to negotiate curved or bend tubes.

The model "P" & "TC" is for heavy and hard tube deposits as found in refinery and still tubes. It is tough in its parts and assembly as necessary to stand up in this service and it makes economical provision, as described below, for inevitable wear due to large forces which must transmit through the assembly. The model "P" & "TC" is conformed to do its work quickly and thoroughly even when deposits are of varying thickness and hardness.

Cone cutters, with tapered cutting edges at the front of the cutter head, expand against tube deposits by centrifugal force and break up uneven shoulders of scale. This is followed by long rows of expanding "no-track" cutter wheels which finish up with thorough, repeated cuts. Centrifugal force assures good working contact between tube deposits and cutting edges and "no track" means that cutters cannot fall into a pattern which skips over and leaves strips of scale behind.

The expansion range (range of cutter head diameters) of these cutter heads is considerable (See chart below.) and is due to (1) slotted cutter pin bearing bores and (2) intentional "play" in pin bearing inserts, features which include an economical bonus. Large cutter forces transmit through and wear the cutter pin bearing bore. By designing this bore into a replaceable insert, cutter body life is greatly increased, obviously providing increased economy of operation and service life.

Model No.	Tube I.D. inch	Minimum Dia. Over Cutter inch.	Minimum Dia. Over Cutter inch.	Cone Cutter Set Model No.	Cylinder Cutter Set Model No.	Cutter Pin Set Model No.
TC-14	1.1/2	1.3/8	1.23/32	1787-1	1788-2	1584-1
TC-11	1.3/4	1.5/8	2	1587-1	1588-2	1584-1
TC-17	1.7/8	1.11/16	2	2287-3	2288-6	1584-3
TC-16	2	1.13/16	2.3/16	1787-3	1788-6	1584-PY
TC-13	2.1/8	1.15/16	2.5/16	1787-3	1788-6	1584-PY
P-15	2.1/4	2.1/16	2.7/16	2487-3	3338-6	2484-PY
P-9-S	2.3/8	2.3/16	2.11/16	C52-3	C76-6	2484-3
P-9	2.1/2	2.1/4	2.13/16	1587-3	1588-6	1584-PY
P-8	2.5/8	2.9/16	2.7/8	1087-3	1088-6	184-3
P-7	2.3/4	2.9/16	2.15/166	1087-3	1088-6	184-3
P-6-A	3	2.11/16	3.1/8	1087-3	1088-6	184-3
P-6	3.1/8	2.13/16	3.1/4	1087-3	1088-6	184-3
P-5	3.1/4	3.1/16	3.9/16	987-3	988-6	184-3
P-4	3.1/2	3.3/16	3.13/16	787-3	788-6	884-3
P-3	3.3/4	3.9/16	4.3/16	887-B3	888-B6	884-3
P-2	4	3.3/4	4.1/2	887-3	888-6	884-3
P-1	4.1/4	3.13/16	4.3/4	887-3	888-9	884-P3
P-0	4.1/2	4.1/8	4.15/16	887-3	888-9	884-P3
P-10	4.3/4	4.3/8	5.3/16	887-3	888-9	884-P3
TC-19-H-S	5	4.1/2	5.9/16	1287-3	1288-9	884-P3
TC-19-S	5.1/4-5.1/2	4.7/8	5.15/16	1287-4	1288-12	884-P4
TC-20-S	6	5.1/2	6.1/2	1287-4	1288-12	884-P4
TC-21-S	6.1/4	5.3/4	6.3/4	11887-4	11888-12	884-P4
TC-22-S	6.1/2	6	7.1/16	11887-4	11888-12	884-P4
TC-23-S	6.3/4	6.1/4	7.5/16	8287-4	8288-12	2484-S4
TC-24-S	7	6.1/2	7.9/16	8287-4	8288-12	2484-S4



# TUBE CLEANER SELECTION GUIDE

## TUBE CLEANER QUICK SELECTION

Vessel	Type of Tube	Deposit	Machine	Recommended Cleaning Tools
Heat Exchanger Condenser	Non-Ferrous Straight 1/4"-1" (6.4-25.4mm)	Soft Deposits	PTC-40, PTC-60, PORTO	Nylon Brush
Heat Exchanger Condenser	Non-Ferrous Straight 1/4"-1" (6.4-25.4mm)	Medium to Hard Scale	PTC-40, PTC-60, PORTO	Carbide Drill
Heat Exchanger Condenser	Non-Ferrous U-Tube 1/2"-1" (12.7-25.4mm)	Soft Deposit	PTC-40, PTC-60, PORTO	Cup Brush, Wheel Brush
Heat Exchanger Condenser	Non-Ferrous U-Tube 1/2"-1" (12.7-25.4mm)	Hard Scale or Blockage	PTC-40, PTC-60, PORTO	Cobalt Tip Tool
Heat Exchanger Condenser	Ferrous Straight 1/4"-1" (6.4-25.4mm)	Soft Deposit Light Scale	PTC-40, PTC-60, PORTO	Stainless Steel Brush
Heat Exchanger Condenser	Ferrous Straight 1/4"-1" (6.4-25.4mm)	Medium to Hard Scale	PTC-40, PTC-60, PORTO	Carbide Drill, Wheel Brush Tool
Heat Exchanger Condenser	Ferrous U-Tube 1/2"-1" (12.7-25.4mm)	Soft Deposit Light Scale	PTC-40, PTC-60, PORTO	Cup Brush, Wheel Brush Tool
Heat Exchanger Condenser	Ferrous U-Tube 1/2"-1" (12.7-25.4mm)	Hard Scale or Blockage	PTC-40, PTC-60, PORTO	Cobalt Tip Tool
Heat Exchanger Condenser	Non-Ferrous Straight 1/4"-1" (6.4-25.4mm)	Soft Deposit	C-10 with Hollow Tube	Nylon Brush, Brass Brush
Heat Exchanger Condenser	Ferrous Straight 1/4"-1" (6.4-25.4mm)	Soft Deposit	C-10 with Hollow Tube	Stainless Steel Brush
Heat Exchanger Condenser	Non-Ferrous Straight 5/16"-1" (7.9-25.4mm)	Medium to Hard Scale	C-10 with Hollow Tube	Buffing Tool with Drill Tip, Carbide Drill
Heat Exchanger Condenser	Non-Ferrous or Ferrous Straight 3/16"-3/8" I.D. (4.8-9.5mm)	Hard Scale Blockage	C-10	Hollow Drills (other diameters and lengths available on request-consult factory for prices and delivery)
Heat Exchanger Condenser	Non-Ferrous or Ferrous Straight 7/8"-2" I.D. (22.2-51.0mm)	Hard Scale Blockage	C-315	HCD Series Carbide Drills
Heat Exchanger Condenser	Non-Ferrous or Ferrous Straight 3/16"-1" I.D. (4.8-25.4mm)	Hard Scale Blockage	C-10 with Hollow Tube	Carbide Drills
Heat Exchanger Condenser	Non-Ferrous Straight 1"-14" I.D. (25.4-355.6mm)	Soft Deposit	PTC-75	Buffing Tool, Wing Tool-Flexible Arm-Carbide Ball Tip, Carbon Steel Brush
Heat Exchanger Condenser	Non-Ferrous Straight 1"-14" I.D. (25.4-355.6mm)	Medium to Hard Scale	PTC-75	Buffing Tool, TCB Brush, Wing Tool-Stiff Arm Cutter
Heat Exchanger Condenser	Ferrous Straight 1"-14" I.D. (25.4-355.6mm)	Soft Deposit	PTC-75	Buffing Tool, Wing Tool-Flexible Arm-Carbide Ball Tip, CBTS Brush, Carbon Steel Brush
Hoses	Plastic 1.1/4"-14" I.D. (31.7-355.6mm)	Soft Deposit	PTC-75	Nylon Brush and Plastic Brushes
Firetube Boiler	Straight Steel 1.3/8"-4" O.D. (35.0-101.6mm)	Soot and Light Scale	PTC-75	Buffing Tool, CBTS Series Brush
Firetube Boiler	Straight Steel 1.3/8"-4" O.D. (35.0-101.6mm)	Hard Heavy Scale	PTC-150	Scraper Tool, Cone Cutter Tool, Wing Tool-Stiff Arm Cutter
Vaccum Pan, Juice Heater	Ferrous Straight 1.18"-1.49" I.D. (30.0-38.0mm)	Medium to Hard Scale	TC-30	HZ Cutter, H Cutter, TH Brush, WBA Brush, DS Brush
Vaccum Pan, Juice Heater	Ferrous Straight 1.53"-2.55" I.D. (38.4-65.0mm)	Medium to Hard Scale	TC-50	H Cutter, WA Cutter, SA Cutter, TH Brush, DS Brush, WBA Brush
Vaccum Pan, Juice Heater	Ferrous Straight 2.59"-3.93" I.D. (66.0-100.0mm)	Medium to Hard Scale	TC-75	H Cutter, WA Cutter, SA Cutter, TH Brush, DS Brush, WBA Brush
Watertube Boiler	Straight Steel 1"-3.1/4" I.D. (25.4-82.6mm)	Soft Deposit Light Scale	PTC-75	Buffing Tool, CBTS Brush, Wing Tool-Flexible Arm-Carbide Ball Tip
Watertube Boiler	Straight Steel 1"-3.1/4" I.D. (25.4-82.6mm)	Medium to Hard Scale	PTC-75	Buffing Tool, Cylinder Cutter Tool



*Powermaster exports Tube Expanding, Tube Cleaning and related equipment to over 120 countries worldwide.*

## TUBE CLEANER SPECIFICATIONS QUICK REFERENCE GUIDE

Model	Pages	Tube Size	Motor Power	Power Source	Shaft/Drill Speed
PTC-40	94	1/4"-1" I.D. (6.4-25.4mm)	1/2 HP (0.40 kW)	Electric 110 or 220V, 50 or 60 Hz	890 rpm
PTC-60	94	1/4"-1" I.D. (6.4-25.4mm)	3/4 HP (0.60 kW)	Electric 110 or 220V, 50 or 60 Hz	890 rpm
PTC-75	94	1" & UP I.D. (25.4mm & UP)	1 HP (0.75 kW)	Electric 110 or 220V, 50 or 60 Hz	1780 rpm
PTC-150	94	1" & UP I.D. (25.4mm & UP)	2 HP (1.50 kW)	Electric 110 or 220V, 50 or 60 Hz	1780 rpm
PORTO	98	1/4"-1" I.D. (6.4-25.4mm)	1/2 HP (0.40 kW)	Electric 110 or 220V, 50 or 60 Hz	1760 rpm
C-10	109	3/16"-1" I.D. (4.8-25.4mm)	0.6 HP (0.45 kW)	Air:Min.60psi@16cfm	700 rpm
C-315	109	7/8"-2" I.D. (22.2-51.0mm)	1 HP (0.75 kW)	Air:Min.90psi@20cfm	1000 rpm

# SPECIAL TABLES

### Recommended Expansion of Tubes for Optimum Joint Strength in Heat Exchanger and Condensers

Use expansion listed in the tube expansion column plus clearance between tube O.D. and sheet hole I.D.

Recommended expansion may be plus or minus .001 in. (0.25mm).

Tube O.D.		Gauge	Tube Expansion		Tube O.D.		Gauge	Tube Expansion		Tube O.D.		Gauge	Tube Expansion	
mm	inch		mm	inch	mm	inch		mm	inch	mm	inch		mm	inch
12.7	1/2	14	.15	.006	15.8	5/8	20	.10	.004	25.4	1	10	.22	.009
12.7	1/2	15	.15	.006	15.8	5/8	21	.10	.004	25.4	1	11	.22	.009
12.7	1/2	16	.15	.006	19.0	3/4	10	.20	.008	25.4	1	12	.22	.009
12.7	1/2	17	.12	.005	19.0	3/4	11	.20	.008	25.4	1	13	.20	.008
12.7	1/2	18	.12	.005	19.0	3/4	12	.20	.008	25.4	1	14	.20	.008
12.7	1/2	19	.10	.004	19.0	3/4	13	.20	.008	25.4	1	15	.17	.007
12.7	1/2	20	.10	.004	19.0	3/4	14	.20	.008	25.4	1	16	.15	.006
12.7	1/2	21	.10	.004	19.0	3/4	15	.17	.007	25.4	1	17	.12	.005
15.8	5/8	12	.15	.006	19.0	3/4	16	.15	.006	25.4	1	18	.12	.005
15.8	5/8	13	.15	.006	19.0	3/4	17	.12	.005	31.7	1.1/4	8	.25	.010
15.8	5/8	14	.15	.006	19.0	3/4	18	.12	.005	31.7	1.1/4	10	.25	.010
15.8	5/8	15	.15	.006	19.0	3/4	19	.12	.005	31.7	1.1/4	12	.22	.009
15.8	5/8	16	.15	.006	19.0	3/4	20	.12	.005	31.7	1.1/4	14	.20	.008
15.8	5/8	17	.12	.005	19.0	3/4	21	.10	.004	31.7	1.1/4	16	.17	.007
15.8	5/8	18	.12	.005	25.4	1	8	.22	.009	31.7	1.1/4	18	.15	.006
15.8	5/8	19	.10	.004	25.4	1	9	.22	.009					

**ADDITIONAL SIZES :**

1/4 in. (6.3 mm) O.D. tube - expand all gauges .003 in. (.07 mm) after contact with tube sheet hole.

3/8 in. (9.5 mm) O.D. tube - expand all gauges .004 in. (.10 mm) after contact with tube sheet hole.

**EXAMPLE :**

3/4 in. (19.0 mm) O.D. x 14 gauge tubes

Recommended expansion .008 in. (.20 mm)  
 Tube sheet hole .760 in. (19.3 mm)

Therefore, expand as follows :

Tube I.D. before expanding .584 in. (14.8 mm)  
 Recommended expansion .008 in. (.20 mm)  
 Clearance between tube and tube sheet hole .010 in. (.25 mm)  
 Finish I.D. .602 in. (15.2 mm)

The above recommendation is based on our experience. However, because of the great variety of materials, tubes, and tube sheets used, some conditions will require experimental rolling to be certain that the rolled joints will be satisfactory.

## TUBE SIZES - BIRMINGHAM WIRE GAUGES

Tube O.D. inch	Birmingham Wire Gauge (Gauge - Inches)																									
	00-380	0-340	1-300	2-284	3-258	4-238	5-220	6-203	7-180	8-165	9-148	10-134	11-120	12-109	13-095	14-083	15-072	16-065	17-058	18-049	19-042	20-035	21-032	22-028	23-025	24-022
1/4																				.152	.166	.180	.186	.194	.200	.206
3/8																.209	.231	.245	.259	.277	.291	.305	.311	.319	.325	.331
1/2															.310	.334	.356	.370	.384	.402	.416	.430	.436	.444	.450	.456
5/8														.407	.435	.459	.481	.495	.509	.527	.541	.555	.561	.569	.575	.581
3/4											.482	.510	.532	.560	.584	.606	.620	.634	.652	.666	.680	.686	.694	.700	.706	
7/8										.607	.635	.657	.685	.709	.731	.745	.759	.777	.791	.805	.811	.819	.825	.831		
1								.670	.704	.732	.760	.782	.810	.834	.856	.870	.884	.902	.916	.930	.936	.944	.950	.956		
1.1/4								.920	.954	.982	1.010	1.032	1.060	1.084	1.106	1.120	1.134	1.152	1.166	1.180	1.186	1.194	1.200	1.206		
1.1/2								1.170	1.204	1.232	1.260	1.282	1.310	1.334	1.356	1.370	1.384	1.402	1.416	1.430	1.436	1.444	1.450	1.456		
1.3/4							1.310	1.344	1.390	1.420	1.454	1.482	1.510	1.532	1.560	1.584	1.606	1.620	1.634	1.652	1.666	1.680	1.686	1.694	1.700	1.706
2					1.524	1.560	1.594	1.640	1.670	1.704	1.732	1.760	1.782	1.810	1.834	1.856	1.870	1.884	1.902	1.916	1.930	1.936	1.944	1.950	1.956	
2.1/4	1.490	1.570	1.650	1.682	1.732	1.774	1.810	1.844	1.890	1.920	1.954	1.982	2.010	2.032	2.060	2.084	2.106	2.210	2.134	2.151						
2.1/2	1.740	1.820	1.900	1.932	1.982	2.024	2.050	2.094	2.140	2.170	2.204	2.232	2.260	2.282	2.310	2.334	2.356	2.370	2.384	2.402						
2.3/4	1.990	2.070	2.150	2.182	2.232	2.274	2.310	2.344	2.390	2.420	2.454	2.482	2.510	2.532	2.560	2.584	2.606	2.620	2.634	2.652						
3	2.240	2.320	2.400	2.432	2.482	2.524	2.560	2.594	2.640	2.670	2.704	2.732	2.760	2.782	2.810	2.834	2.856	2.870	2.884	2.902						
3.1/4	2.490	2.570	2.650	2.682	2.732	2.774	2.810	2.844	2.890	2.920	2.954	2.982	3.010	3.032	3.060	3.084	3.106	3.120	3.134	3.151						
3.1/2	2.740	2.820	2.900	2.932	2.982	3.024	3.060	3.094	3.140	3.170	3.204	3.232	3.260	3.282	3.310	3.334	3.356	3.370	3.384	3.402						
3.3/4	2.990	3.070	3.150	3.182	3.232	3.274	3.310	3.344	3.390	3.420	3.454	3.482	3.510	3.532	3.560	3.584	3.606	3.620	3.634	3.652						
4	3.240	3.320	3.400	3.432	3.482	3.524	3.560	3.594	3.640	3.670	3.704	3.732	3.760	3.782	3.810	3.834	3.856	3.870	3.884	3.902						

Your Local Distributor :



**POWERMASTER ENGINEERS PVT. LTD.**

229, Pragati Industrial Estate, 316, N. M. Joshi Marg, Bombay - 400 011. INDIA.  
Phone: +91.22.2300 0015 Fax: +91.22.2307 3761 email: sales@tubeexpanders.com

[tubeexpanders.com](http://tubeexpanders.com) ■ [tubecleaners.com](http://tubecleaners.com) ■ [impactsocket.com](http://impactsocket.com) ■ [springbalancers.com](http://springbalancers.com)